

Stellar Movements DIY Kit

Assembly Manual

English ver.

Product numbers SM11, SM12, SM13

First edition: 2026- 04- 20

Table of Contents

Introduction	3
Safety / Precautions	4
Parts List	5
Part Shaping	14
Assemble the Time Scales	20
Gear Assembly	22
Bushing	72
Module Assembly	75
Final Assembly	93
How to Use and Enjoy	117
Other Notes	122

Introduction

This manual is the assembly manual for the Stellar Movements DIY Kit with product numbers SM11, SM12, and SM13.

The product number is printed on the sticker attached to the top of the box, for example, “SM11 0650.” The last four digits indicate the serial number.

For assembly manuals of products other than SM11, SM12, and SM13, please contact [info@olenoides.com].

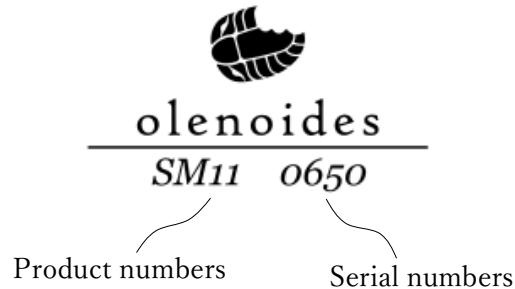

Required Tools

- Phillips screwdriver (for M2, M3 screws): used for general screw fastening.
- Precision screwdriver (for M1.6 screws): used for motor screws.
- Nippers: for removing gears from runners. Scissors can be used as a substitute.
- File: used for shaping PCB components.
- Pliers: used to tighten some nuts.
- Hammer: used to drive shafts into gears.
- Tweezers: used to support small parts.
- White glue (polyvinyl acetate adhesive): mainly used to attach bushes (bushings). We recommend a water-soluble adhesive so corrections are possible.
- Needle applicator: used to apply White glue to small areas.
- Masking tape: for temporarily fixing parts.

Recommended but not required

- Scissors: alternative to nippers.
- Thin gloves: to avoid touching brass parts with bare hands.
- Cloth scraps: to protect painted surfaces during assembly.
- Brush: to remove dust from parts (a painters' brush is OK).
- Mild dish soap (neutral): for cleaning transparent acrylic parts.
- Microfiber cloth (glasses cloth): to remove water droplets from washed acrylic parts.









Safety / Precautions

- Be careful not to hit your hand with the hammer.
- Peel off all protective sheets from acrylic parts before assembly.
- Wash transparent acrylic parts (parts D1–D14, D22, E3-1, L (acrylic dome)) with dish soap before assembly to reduce dust adherence.
- Brass parts are prone to rust; we recommend avoiding direct bare-hand contact or using thin gloves.
- Some high-quantity parts include spare pieces; you may have leftover parts after completion.
- If you break or lose parts during assembly, you can purchase replacement parts individually. Contact [info@olenoides.com]. Note: gears are expensive individually, so handle them with care.
- If you have other questions, please contact [info@olenoides.com].









Parts List

Please check the types and quantities of parts (parts list spans pages 5–13).







A1

			Steel pipe			Plastic pipe		Threaded hole		
										
No.	1	2	3	4	5	6	7	8	9	
Qty.	x16	x1	x8	x7	x1	x1	x2	x4	x8	

A2

			Steel pipe			Plastic pipe		Threaded hole	
									
	1	2	3	4	5	6	7	8	9
	x7	x1	x4	x3	x2	x11	x1	x2	x6

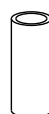
A3

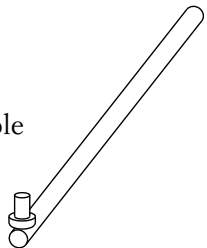
			Steel pipe				Threaded hole	
								
	1	2	3	4	5	6	7	8
	x6	x1	x4	x3	x2	x1	x4	x1

B1

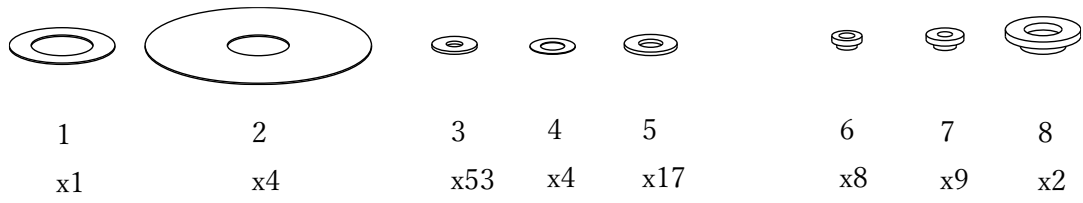

B2

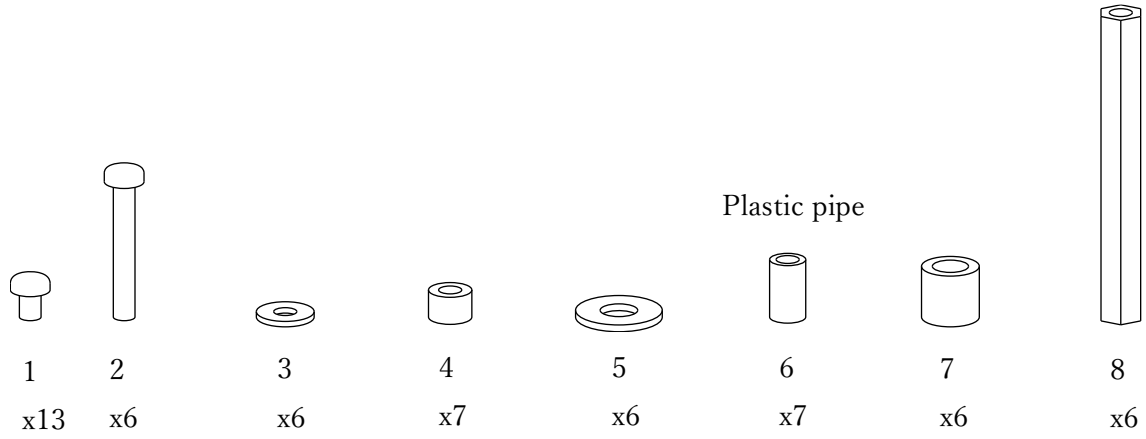

B3

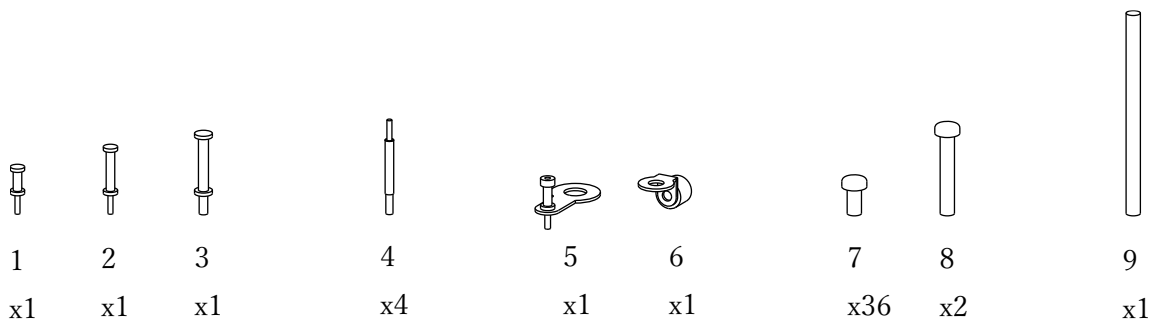

C1

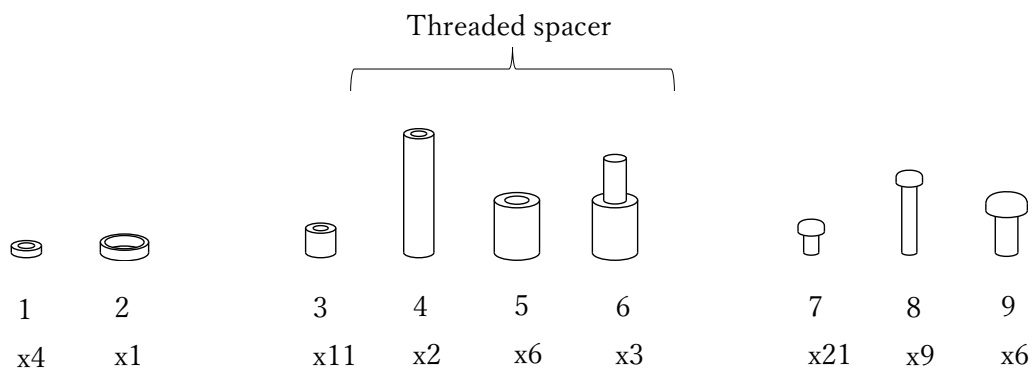

C2

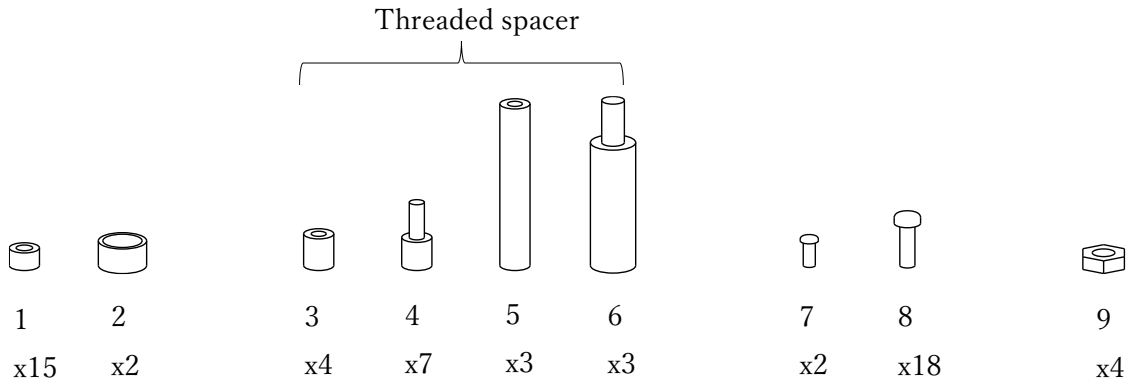

C3

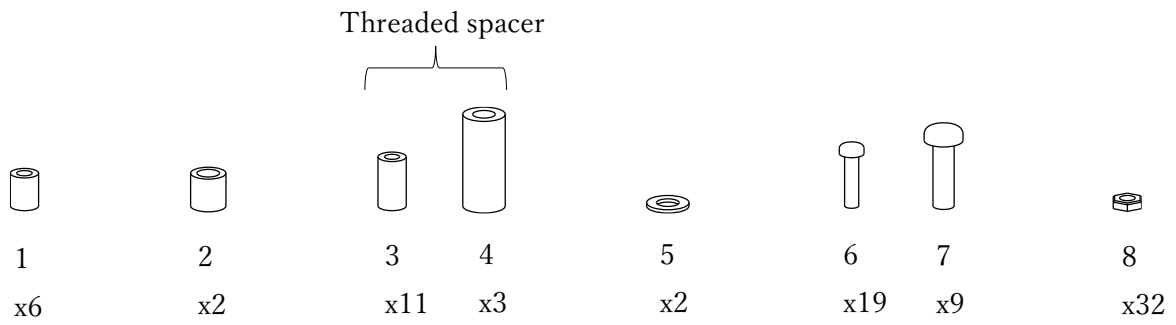

D: Please peel off the protective sheets from acrylic parts (1-14, 22) and clean them.

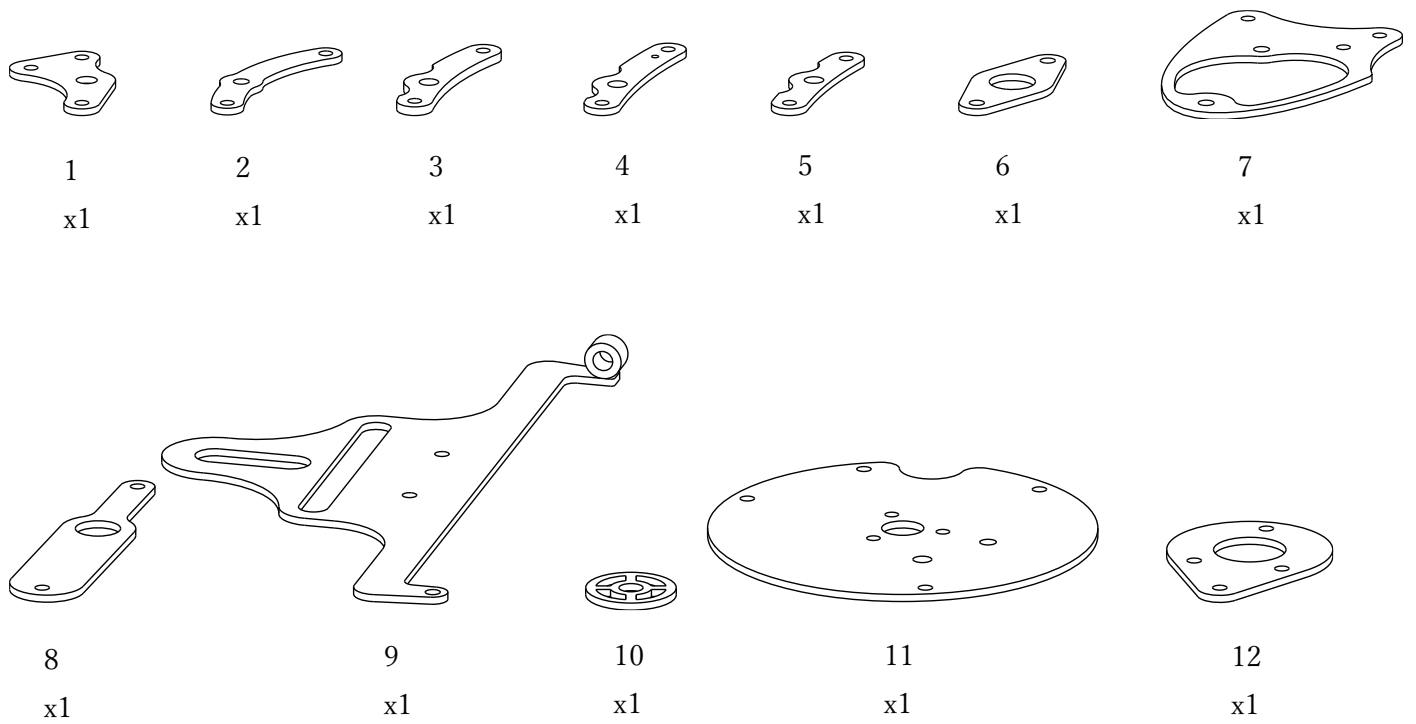

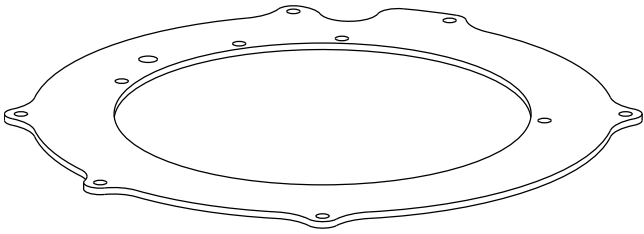

13
x1

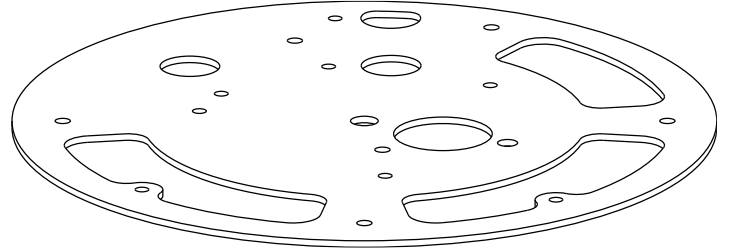

14
x1

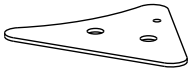

15
x1



16
x3



17
x1



18
x1

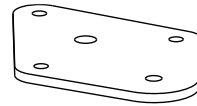

19
x1

Name Plate

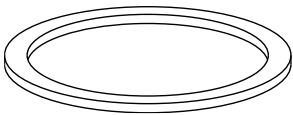

20
x1

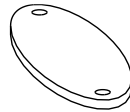

21
x1



22
x1

E1: PCB Parts



1
x1



2
x1



3
x1

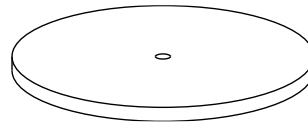

4
x1

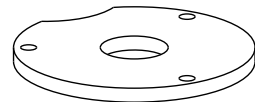

5
x1

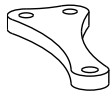

6
x1

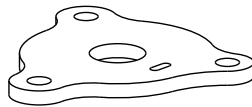

7
x1

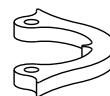

8
x1



9
x1

E2: PCB parts and wood parts

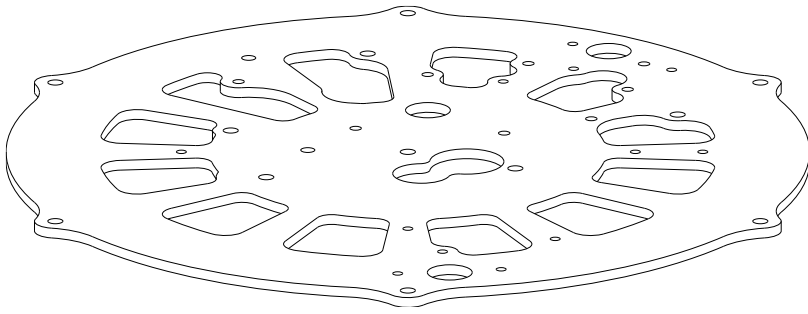

1
x1

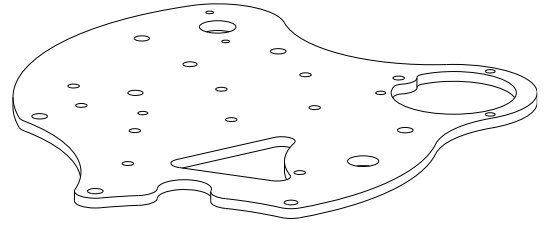

2
x1

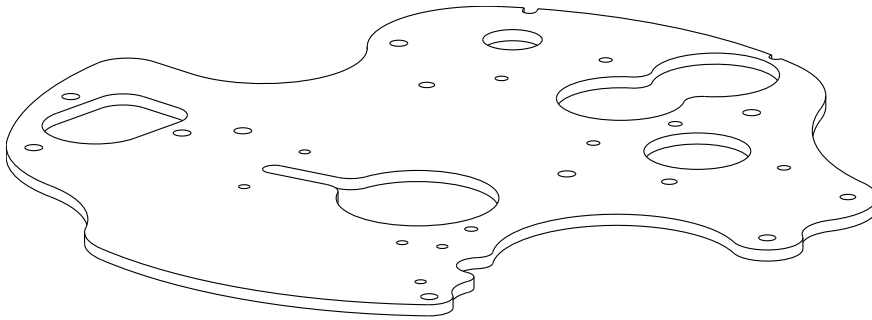

3
x1

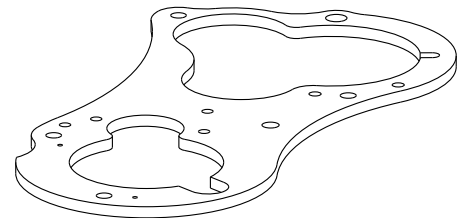

4
x1

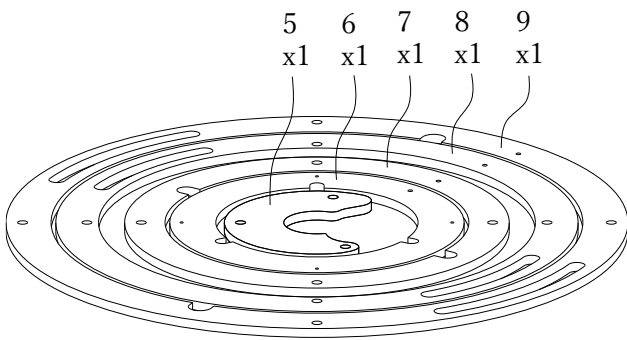

5
x1

6
x1

7
x1

8
x1

9
x1

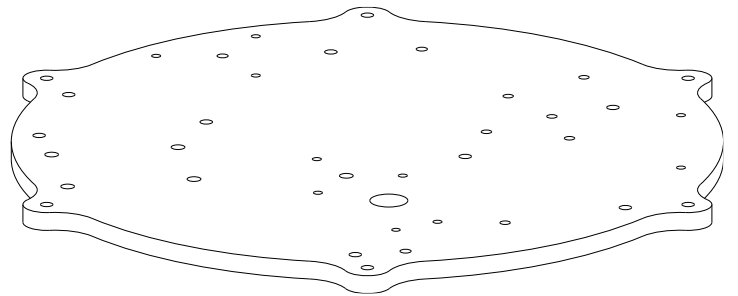

10
x1

E3: Clean E3-1.

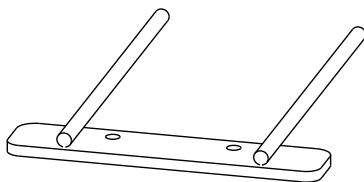

1
x1

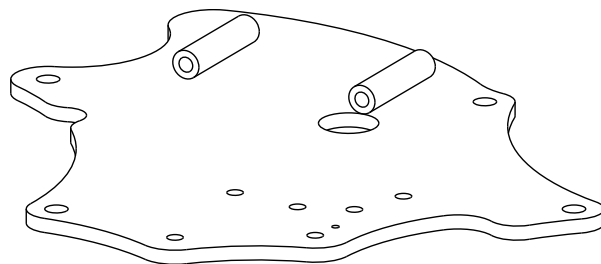

2
x1

G: Gears

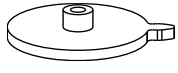

1
x 2



2
x 2



3
x 6



4
x 2



5
x 2



6
x 2



7
x 6



8
x 2



9
x 2



10
x 2



11
x 6



12
x 4

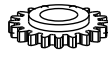

13
x 2



14
x 2



15
x 2



16
x 2

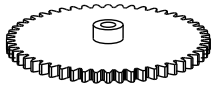

18
x 2

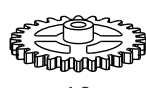

19
x 2

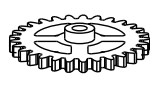

20
x 2

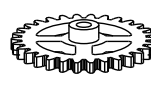

21
x 2

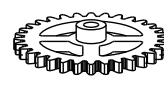

22
x 4

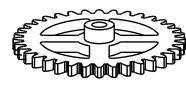

23
x 2

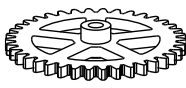

24
x 4

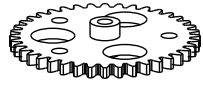

25
x 4

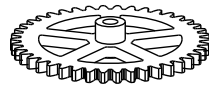

26
x 2

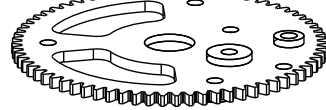

27
x 1

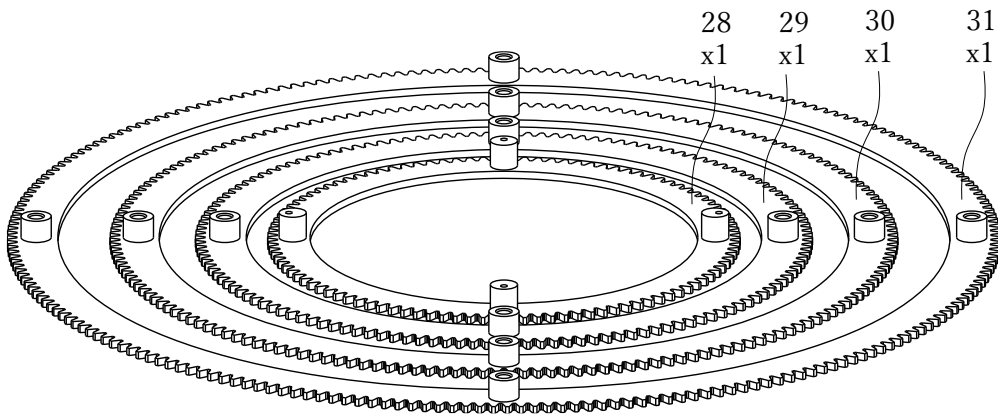

28
x 1

29
x 1

30
x 1

31
x 1

P



1
x 1



2
x 1



3
x 2



4
x 2



5
x 1



6
x 1

No. of teeth 8

No. of teeth 10

H: Electronic components

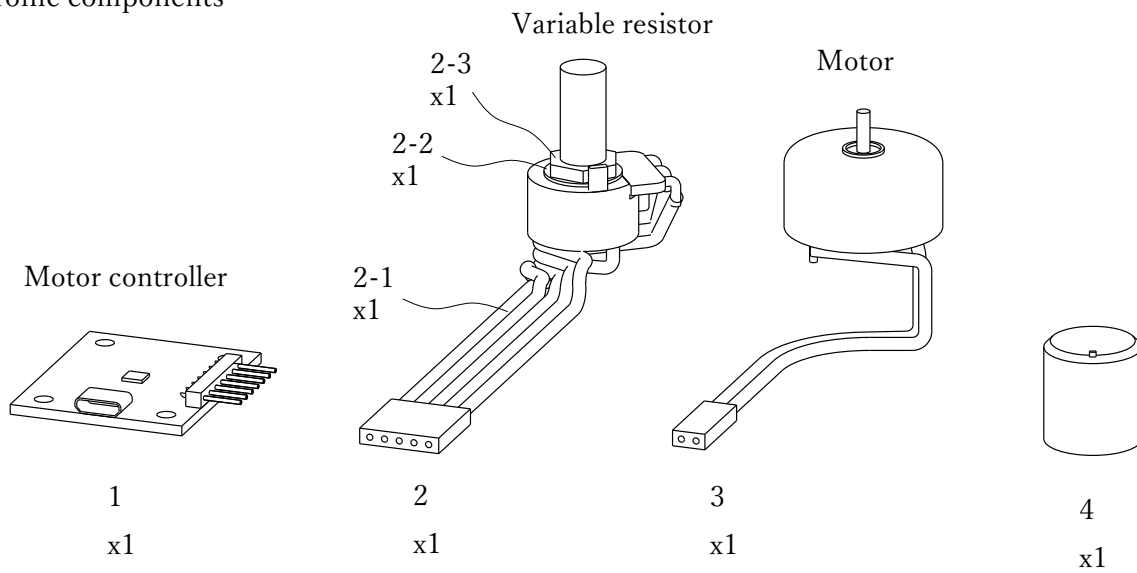

J: Gear-assembly jig

Note: For J10-12, please peel off the protective sheets. Cleaning is not required.

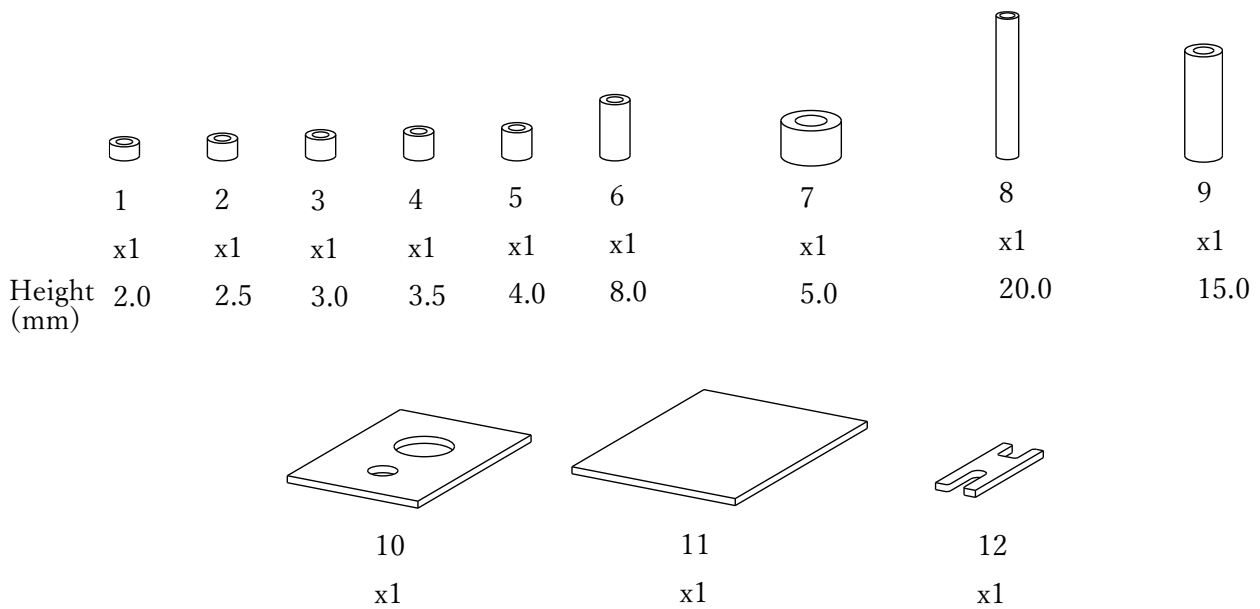

K: Astronomical object

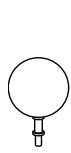

1

x1

Sun



2

x1

Mercury



3

x1

Venus



4

x1

Earth



5

x1

Moon



6

x1

Mars

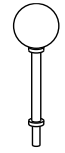

7

x1

Jupiter



8

x1

Saturn



9

x1

Saturn's ring



10

x1

Uranus



11

x1

Neptune



12

x1

Comet

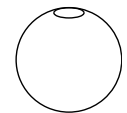

13

x1

Lunar phase

L: Acrylic dome. Please clean it.

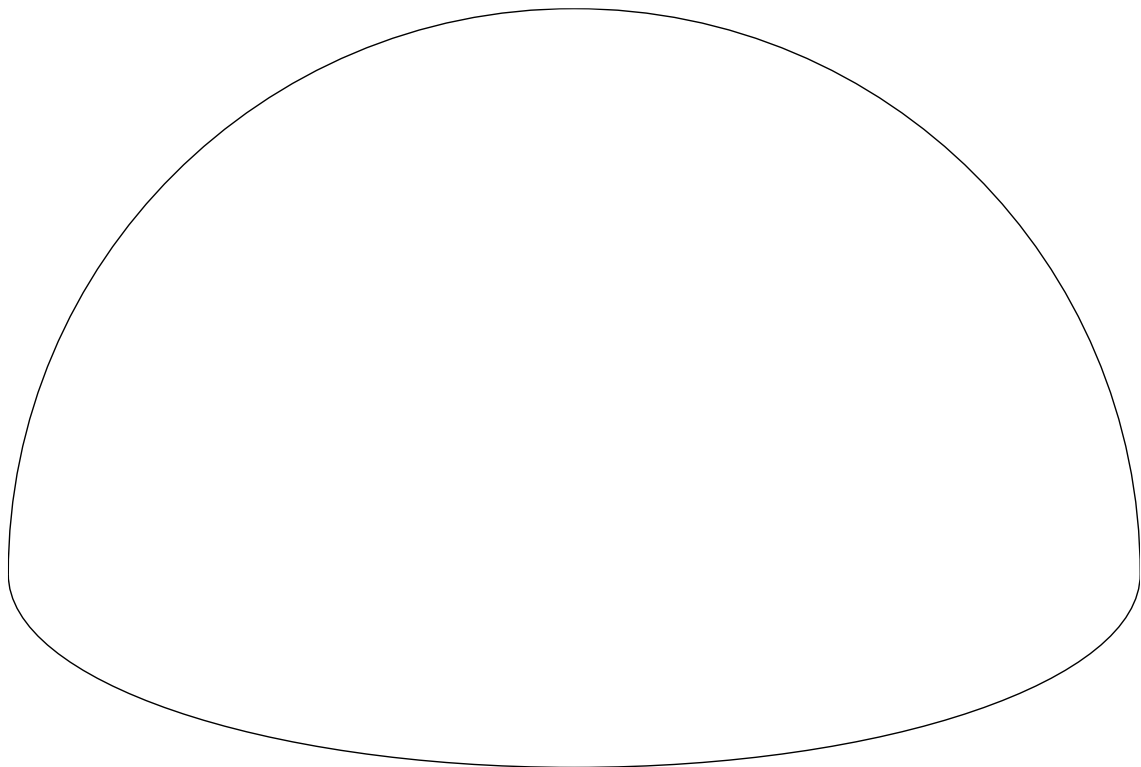

x1

S: Sticker

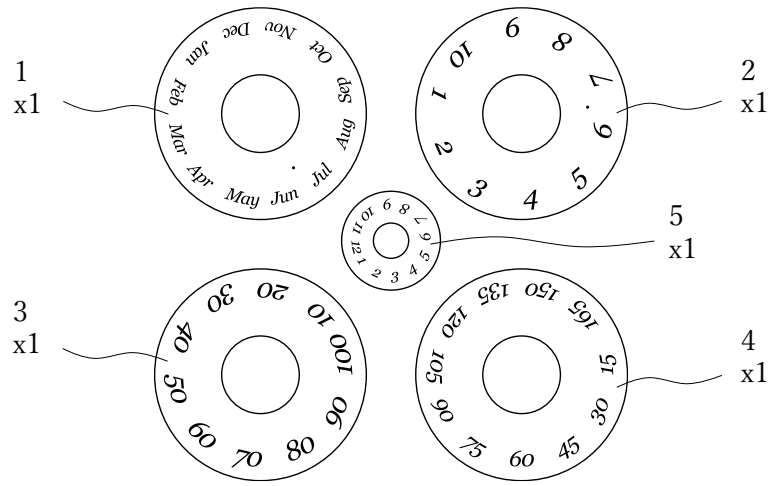

Part Shaping

Remove the runners (protrusions) from parts E1 to E3 and shape them using a file.

First, cut off as much of the runner as possible using nippers, then finish shaping with a file.

The parts are made of glass epoxy laminate (FR-4), which allows for easy filing. However, since the surface coating can peel off easily, it is recommended to file along the perimeter of the part as shown in the illustration.

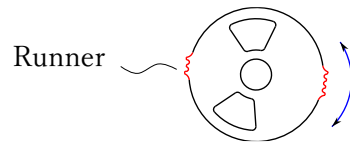

Notes:

Be careful, as the file may slip and scratch the coated surface.

E1-1

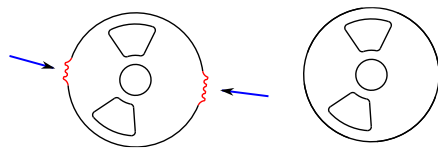

1. Cut off the runner at the indicated arrow using nippers, then file to shape.
2. Complete

E1-2

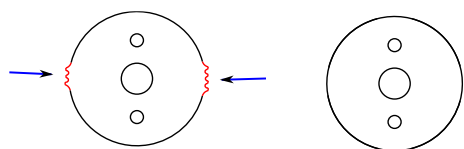

- 1.
2. Complete

E1-2

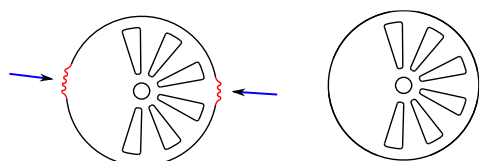

- 1.
2. Complete

E1-3

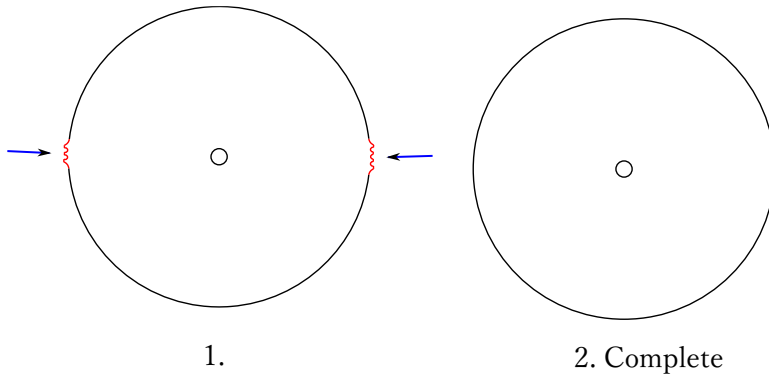

E1-4

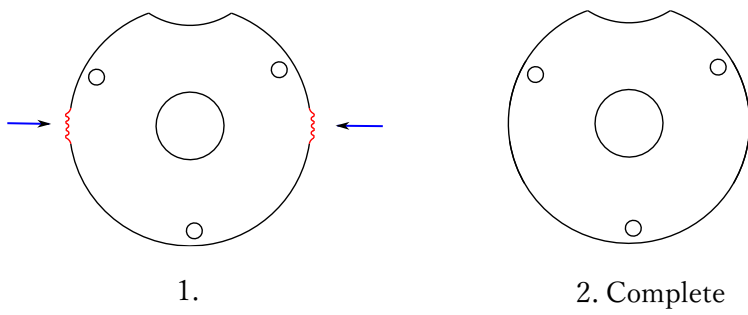

E1-5

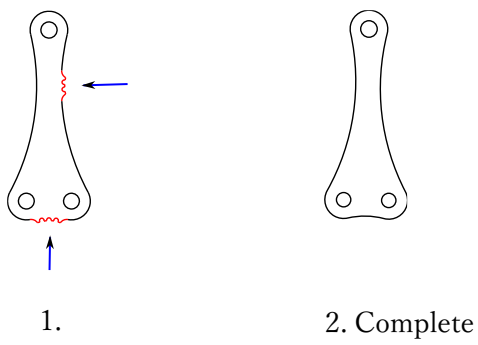

E1-6

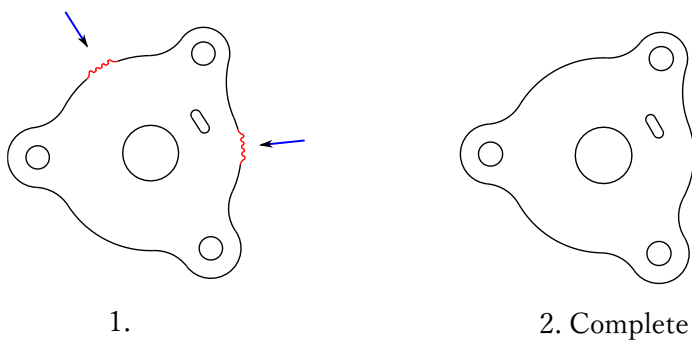

E1-7

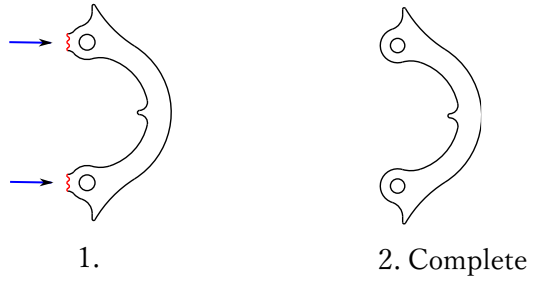

E1-8

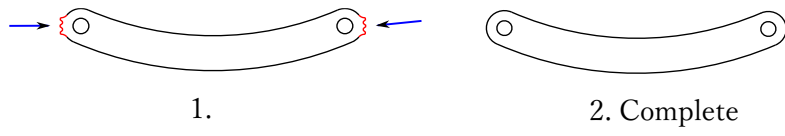

E2-1

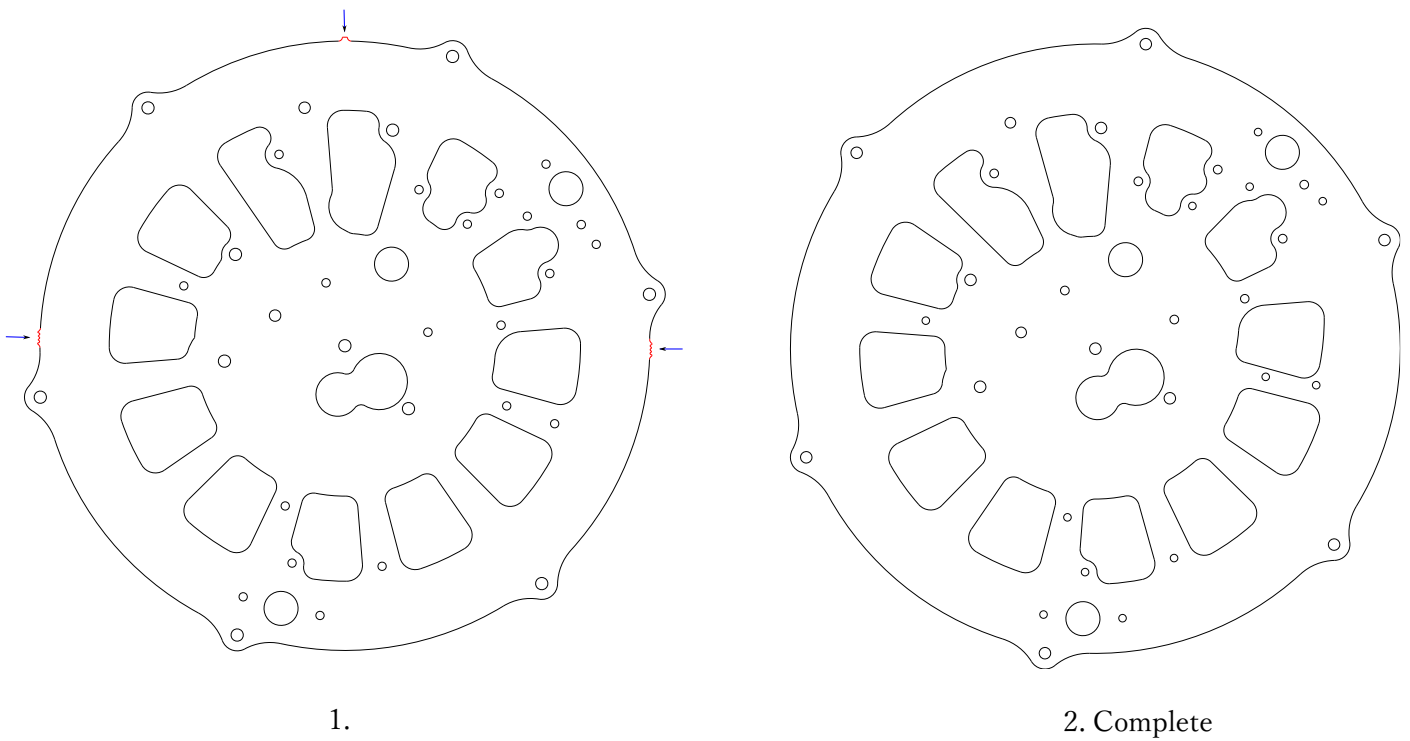

E2-2

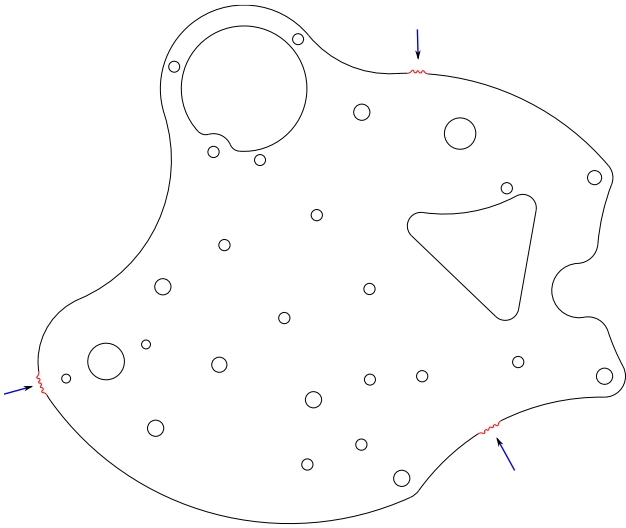

1.

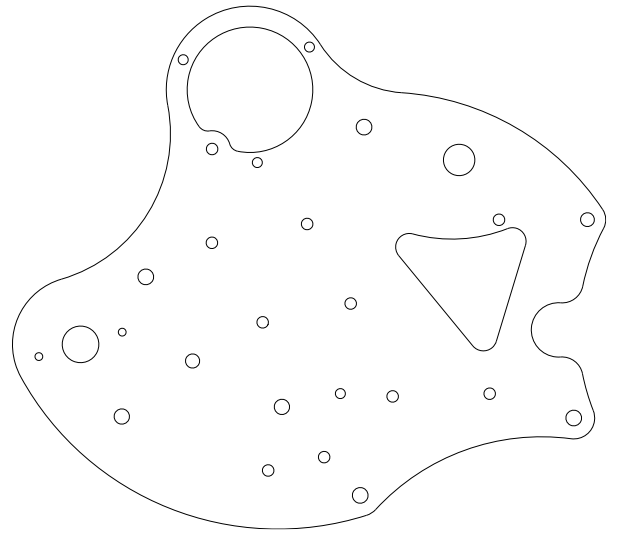

2. Complete

E2-3

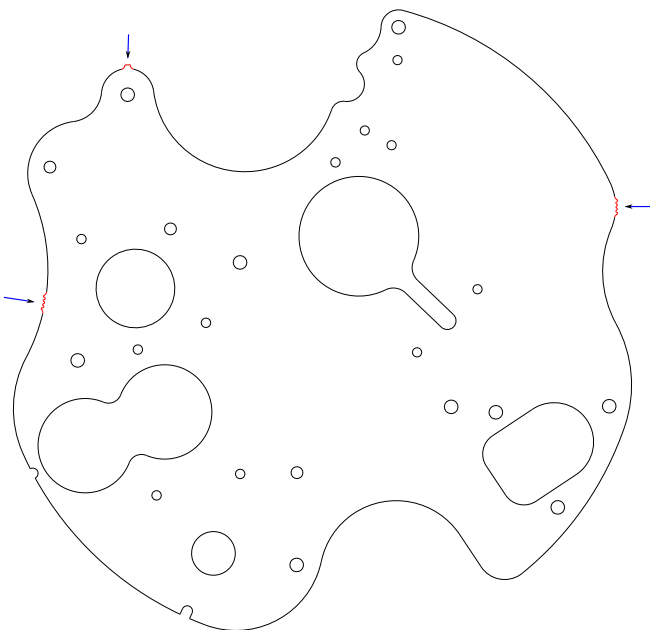

1.

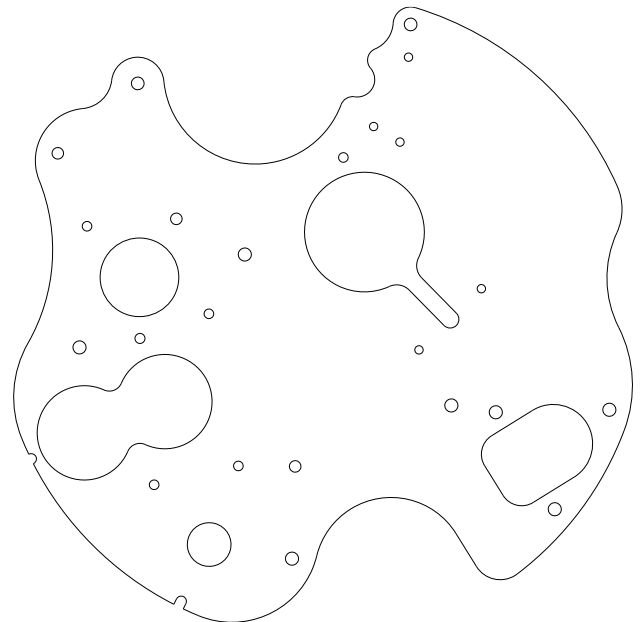

2. Complete

E2-4

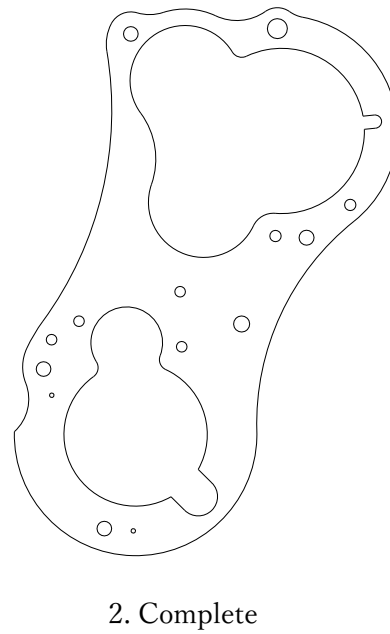
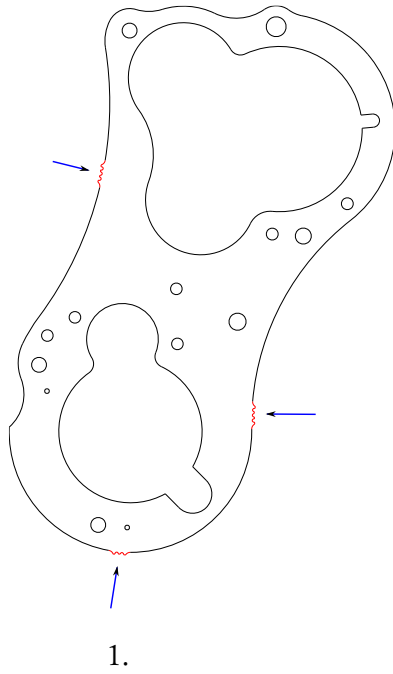

E2-5 ~ E2-9

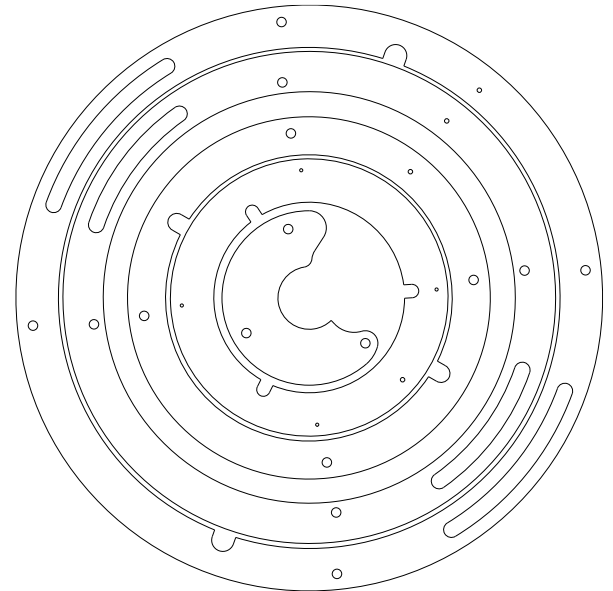
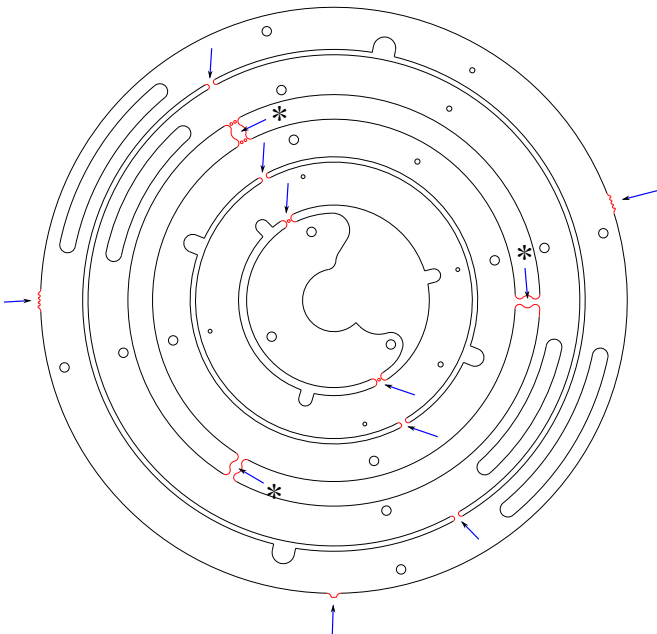

1. Twist the part by hand to break off the runner at the arrow. However, for the areas marked with an asterisk (*), first cut one point with nippers before twisting it off. After that, finish shaping with a file.

Notes: Since the spacing between parts is narrow, minimize the use of nippers. Twisting by hand helps separate the parts without damaging the coated surface.

E3-2

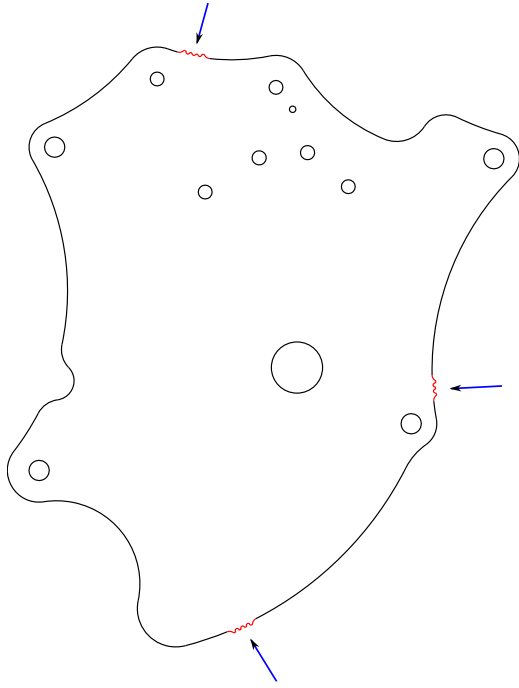

1.

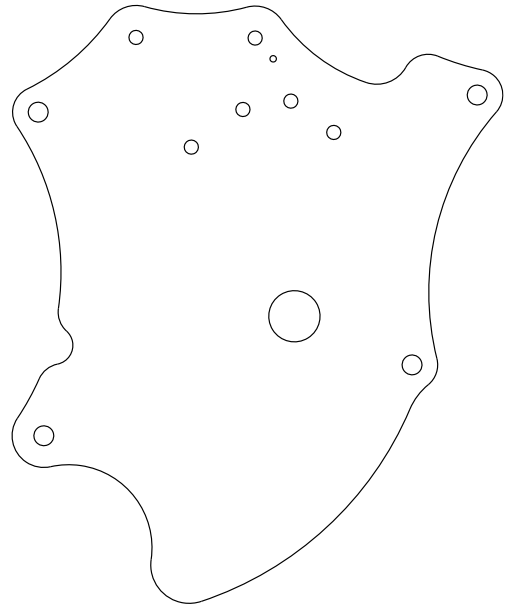

2. Complete

Assemble the Time Scales

Assembly begins here.

Prepare the time scales that will be attached to the gears in advance.

Notes:

- Remove dust from parts with a brush before applying stickers.
- For parts D10, perform assembly after removing protective sheets.

BA1 : month scale

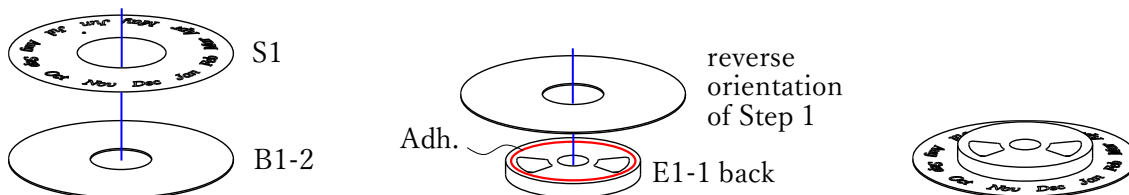

1. Peel off sticker S1 from its backing and apply it to part B1-2. Since S1 and B1-2 are nearly the same diameter, aligning their edges will produce a neat result.

Trim any excess sticker using scissors.

2. Apply adhesive to the back side of E1-1 (the unpainted side), and attach it in the reverse orientation of Step 1, aligning the centers of the holes.

There is no rotational orientation for E1-1.

3. Complete

BA2 : year scale

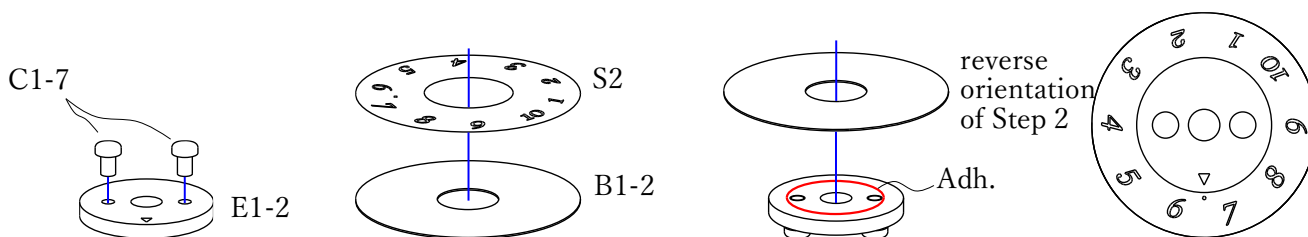

1. With the painted side of E1-2 facing up, screw C1-7 into it until it bottoms out. Be careful not to let C1-7 protrude from the back side of E1-2.

2.

3. Attach in the reverse orientation of Steps 1 and 2, aligning the centers of the holes.

At this time, adjust so that the triangle mark on Step 1 and the point mark on Step 2 point in the same direction (see the right figure).



4. Complete

BA3 : 10 years scale

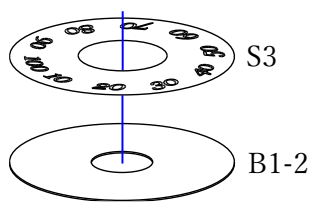

1.

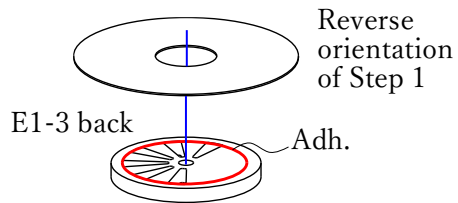

2. Apply adhesive to the back side of E1-3 (the unpainted side), and attach it in the same way as BA1 and BA2.

There is no rotational orientation for E1-3.

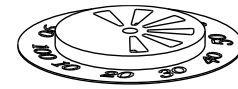

3. Complete

BA4 : Neptune scale

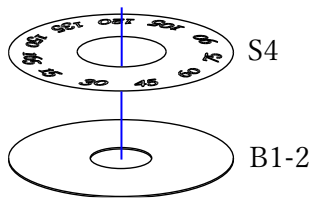

1.

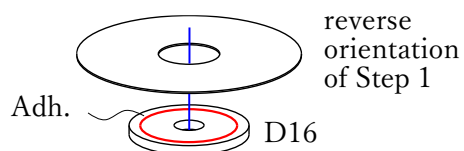

2.

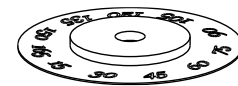

3. Complete

BA5 : Calendar scale

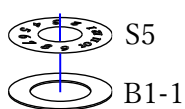

1.

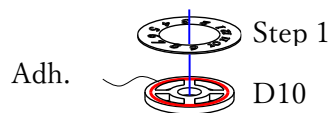

2.



3. Complete

Gear Assembly

Gears must mesh precisely; use jig J for axial positioning.

Jig J is reused repeatedly — do not lose it.

JA1 : Jig Base

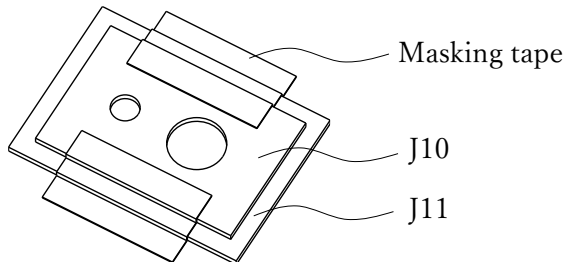

Secure J10 and J11 onto a hard surface using masking tape.

This will serve as a base for securing other jigs.

Notes:

- Fix JA1 onto a hard surface that will not dent when the shaft is hammered in.
- When driving shafts (press-fitting shafts into gears) you need strong force; take care not to hit your hand with the hammer.
- Gears have a front and back on those with a cylindrical boss — the higher boss side is "front" and lower is "back". Gears without a boss have no front/back.
- For small gears, gear numbers are stamped on the runner; twist and remove the gear from the runner before use and smooth the connection point with nippers or scissors.

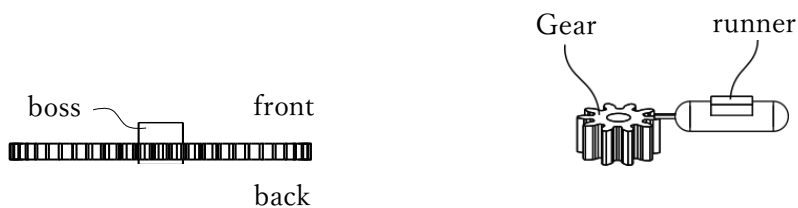

From the next page, the gear assembly begins.

Gather the required parts according to the Completed View, and follow the steps to assemble. Collect jig J as needed.

GA1 : Reduction Gear 1

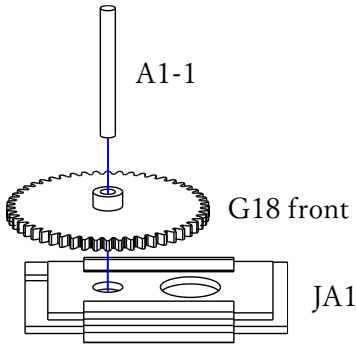
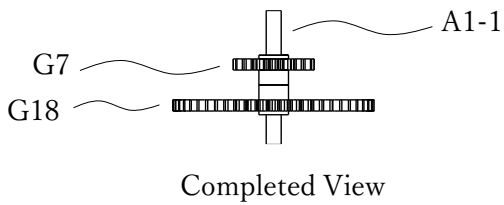

1. Place G18 (front) and A1-1 onto the small indentation of JA1 fixed on the hard surface.

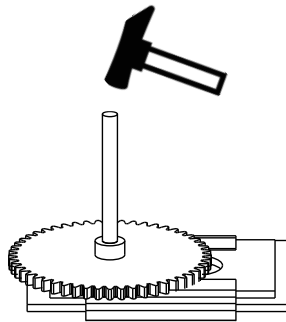

2. Hammer the shaft (A1-1) until it bottoms out. Be careful not to hit your hand.

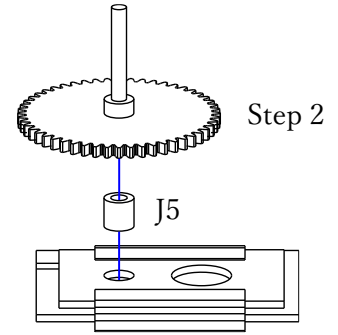

3. Place J5 and the assembly from Step 2 onto the small indentation in order.

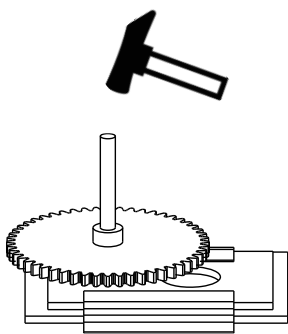

4. Hammer the shaft until it bottoms out. Be careful not to hit your hand.

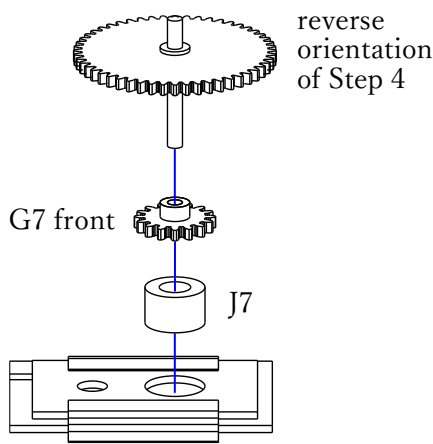

5. Place J7, G7 (front), and the reversed assembly from Step 4 in order onto the large indentation.

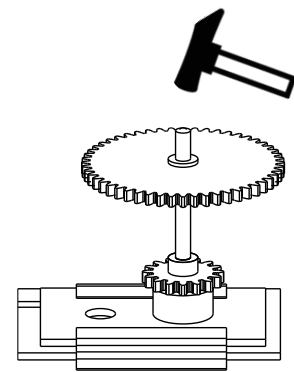

6. Hammer the shaft until it bottoms out. Be careful not to hit your hand.

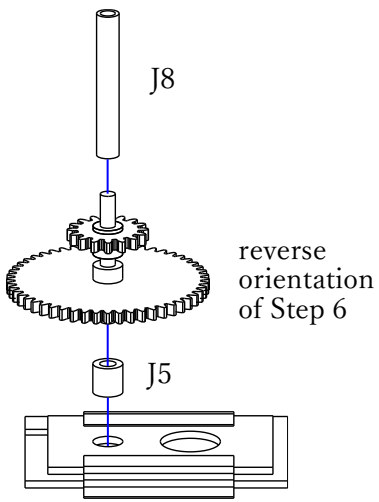

7. Place J5, the reversed assembly from Step 6, and J8 in order onto the small indentation.

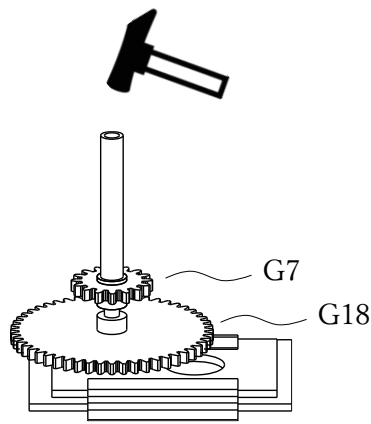

8. Hammer J8 until G7 and G18 come into contact. Be careful not to hit your hand.

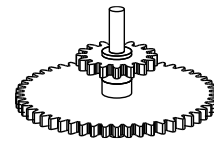

9. Complete

GA2 : Reduction Gear 2

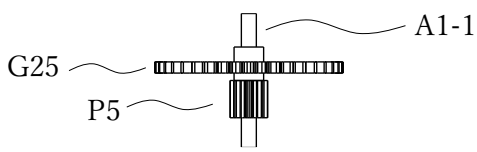

Completed View

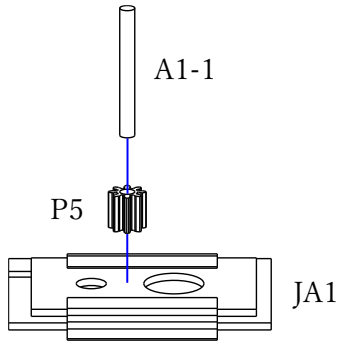

1. Place P5 onto the flat side of JA1, then put A1-1 on top.

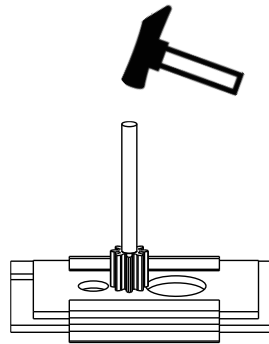

2.

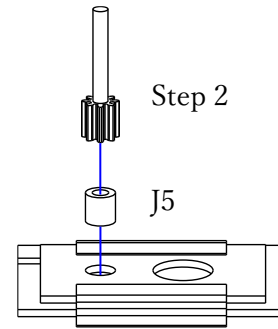

3.

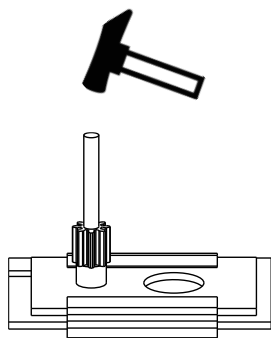

4.

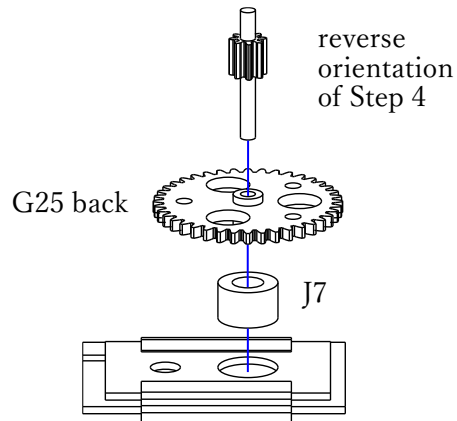

5.

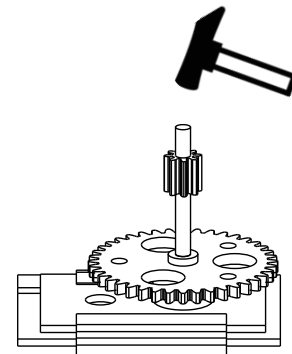

6.

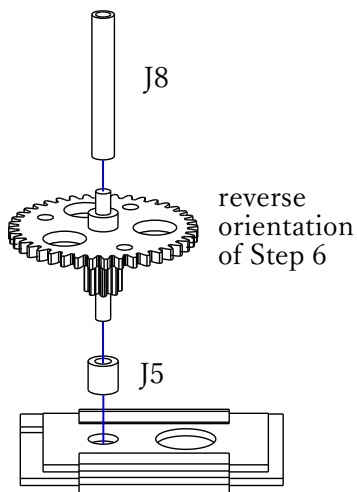

7.

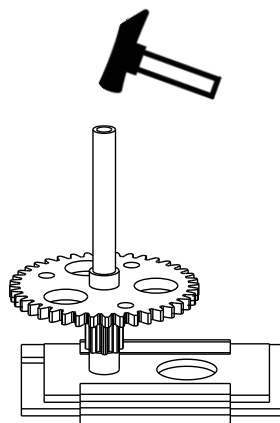

8.

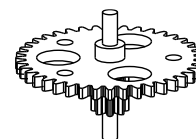

9. Complete

GA3 : Reduction Gear 3

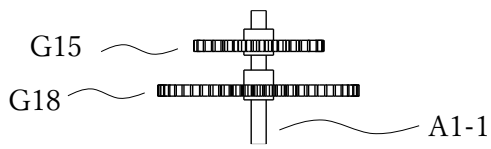

Completed View

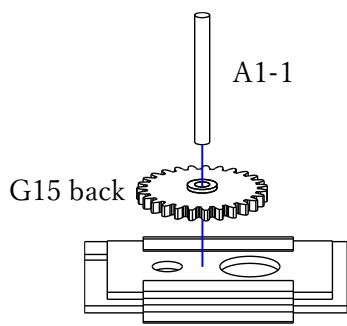

1.

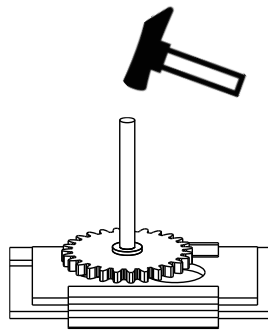

2.

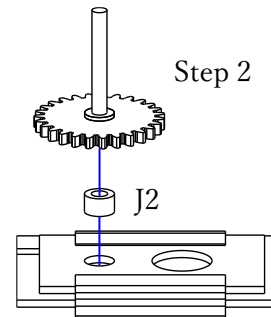

3.

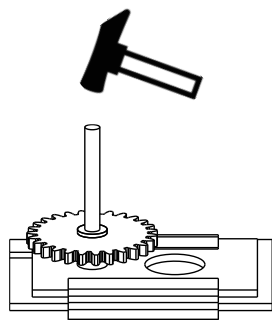

4.

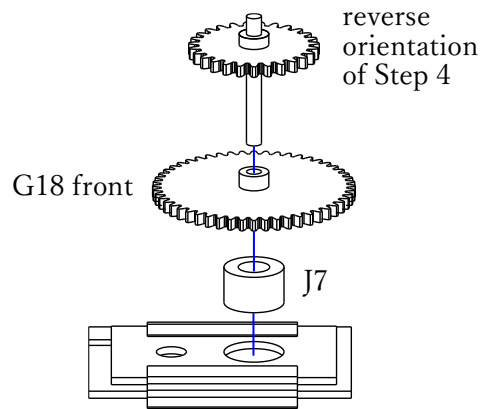

5.

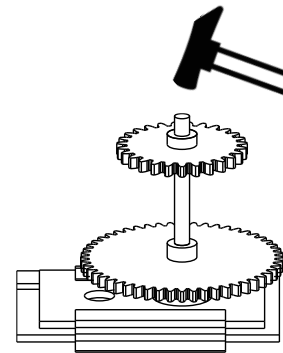

6.

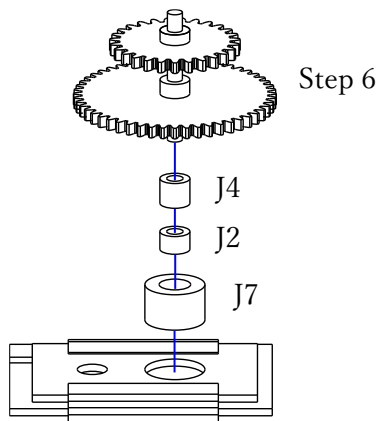

7.

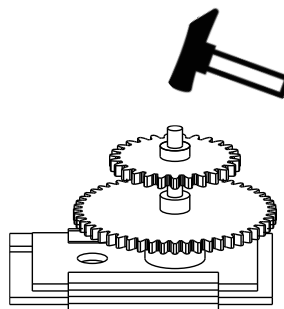

8.

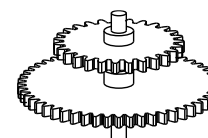

9. Complete

GA4 : Earth Drive Gear

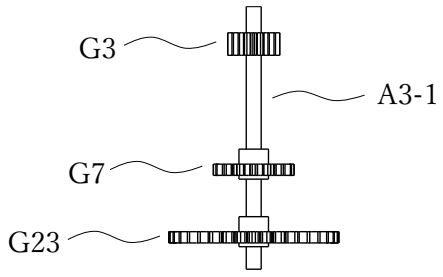

Completed View

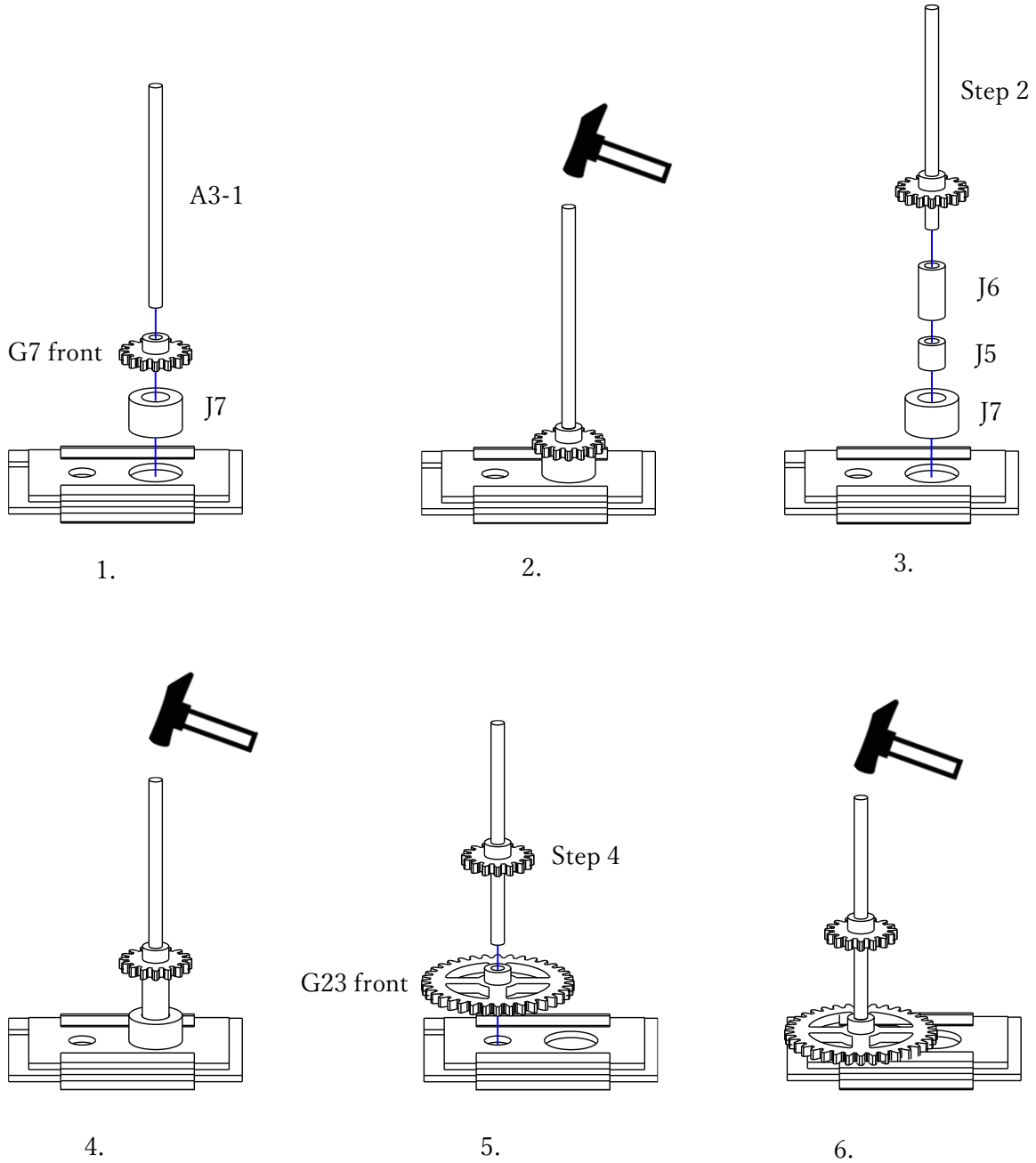

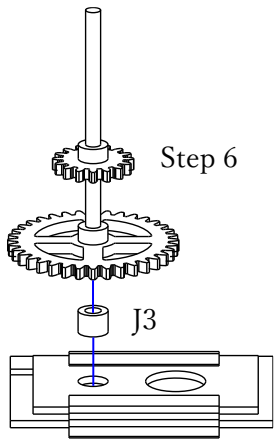

7.

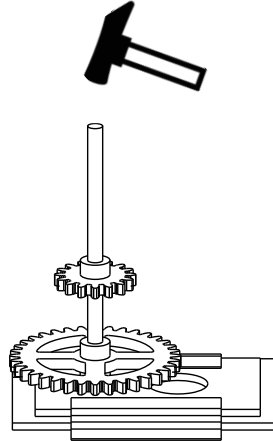

8.

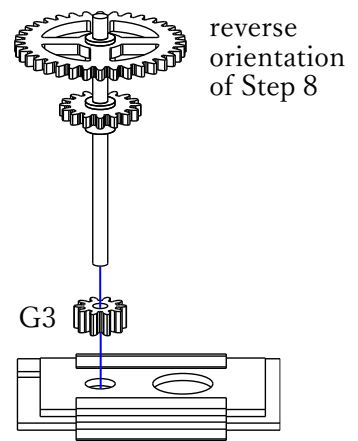

9.

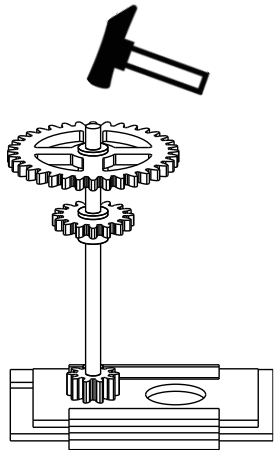

10.

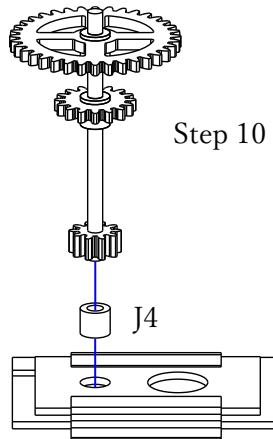

11.

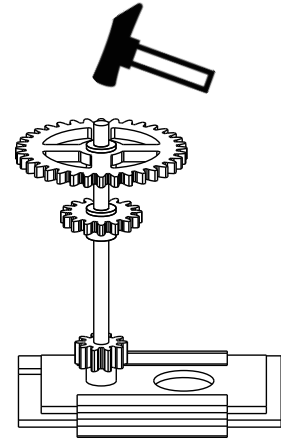

12.

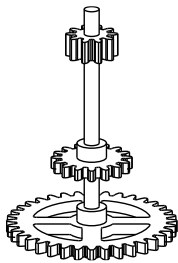

13. Complete

GA5 : Mars–Jupiter Coupling Gear

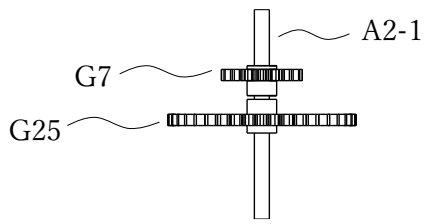

Completed View

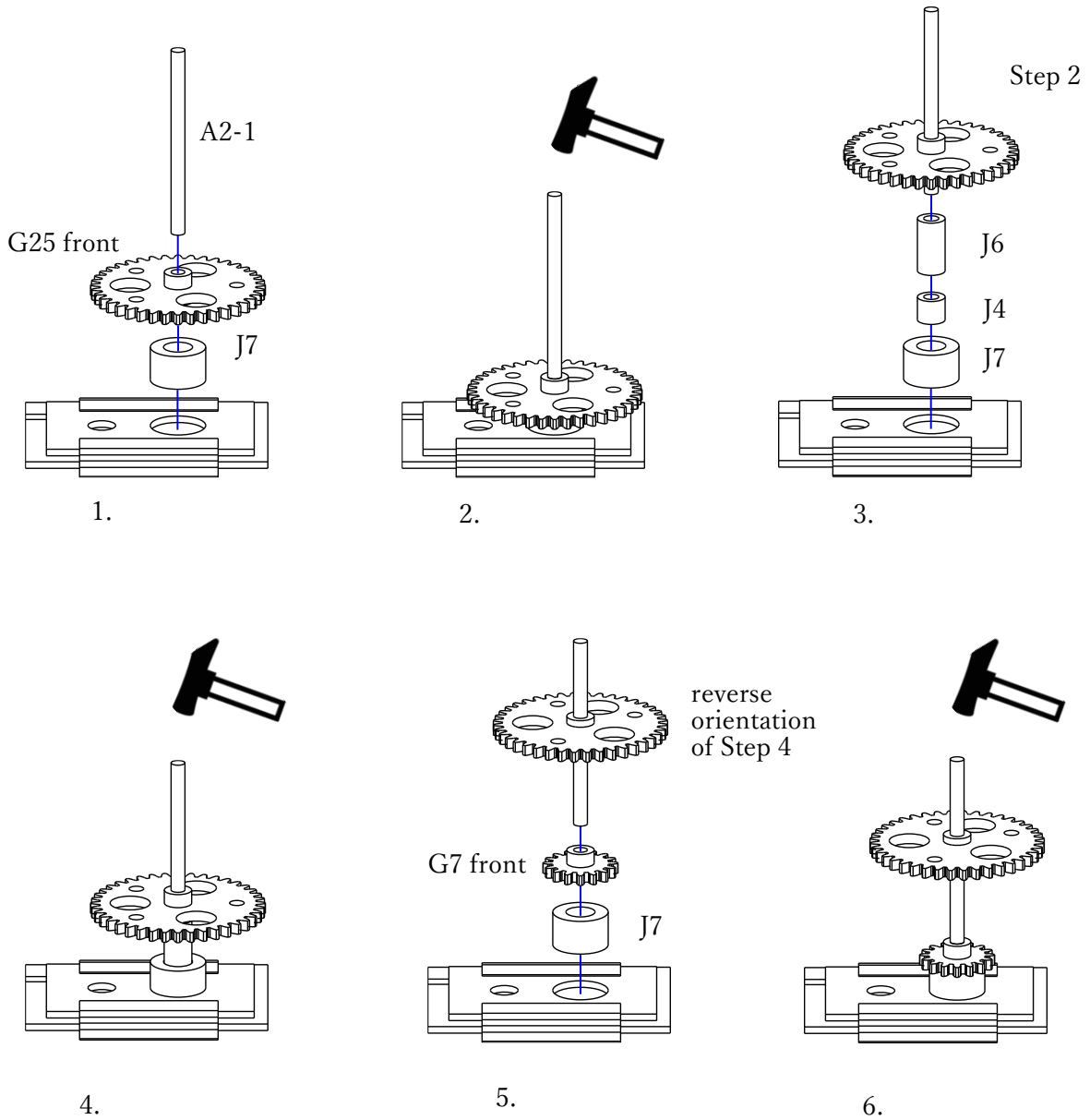

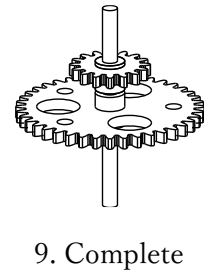
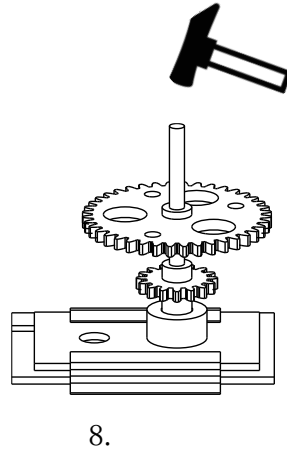
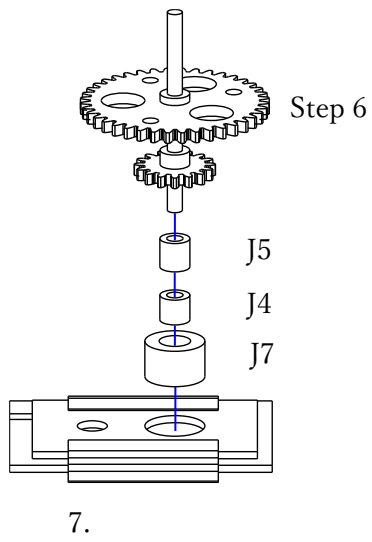

GA6 : Mercury Gear

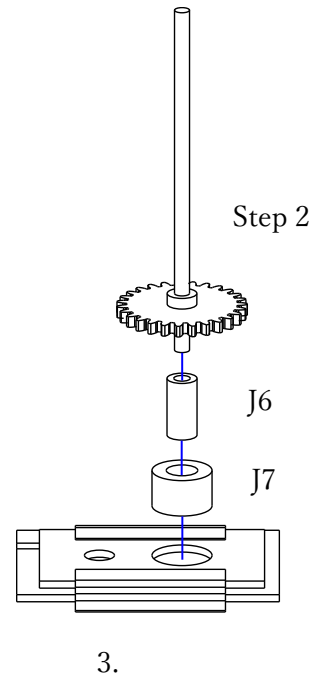
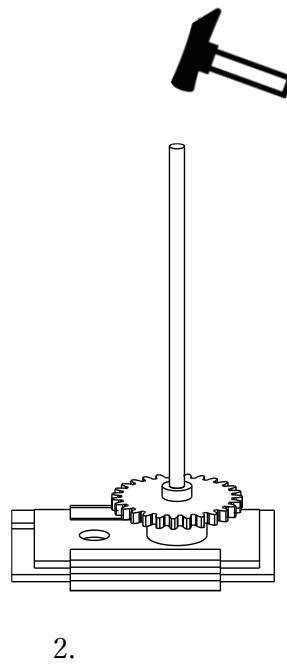
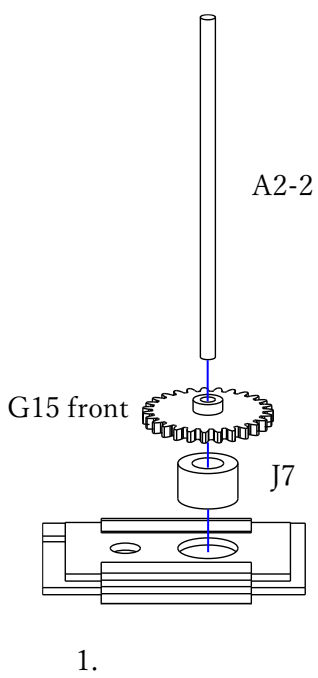
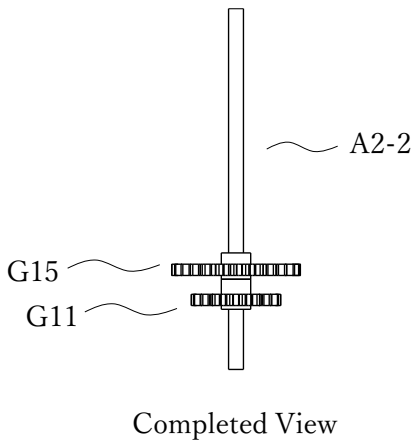

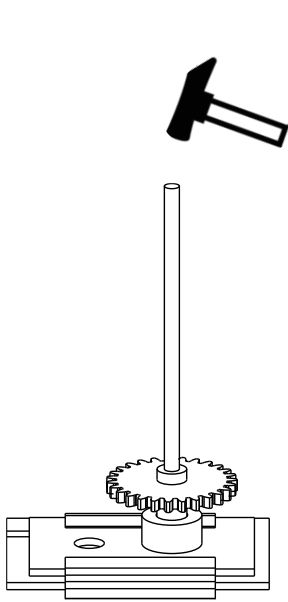

4.

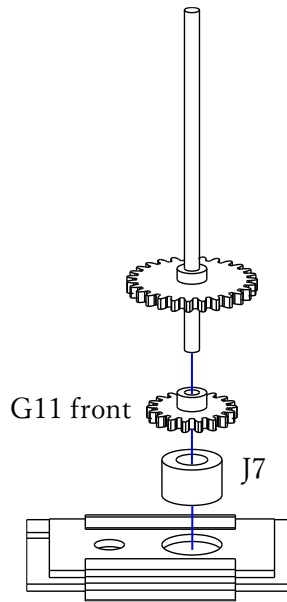

G11 front

J7

5.

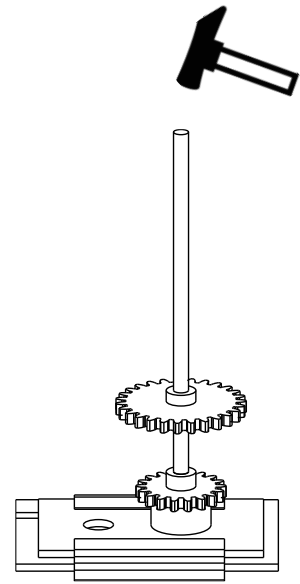

6.

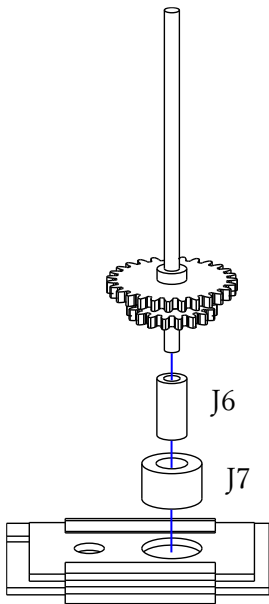

J6

J7

7.

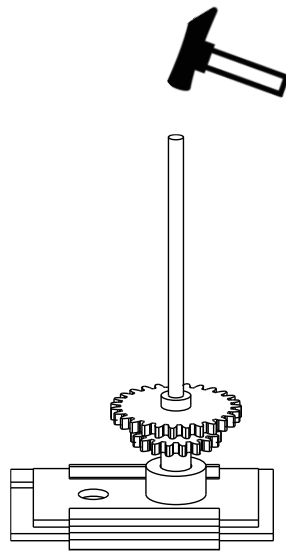

8.

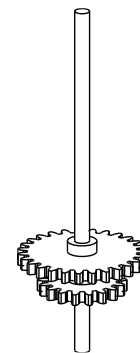

9. Complete

GA7 : Moon Drive System Gear 1

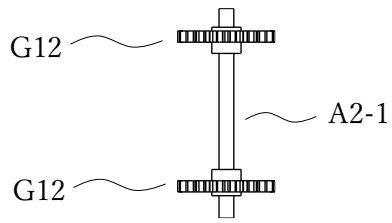

Completed View

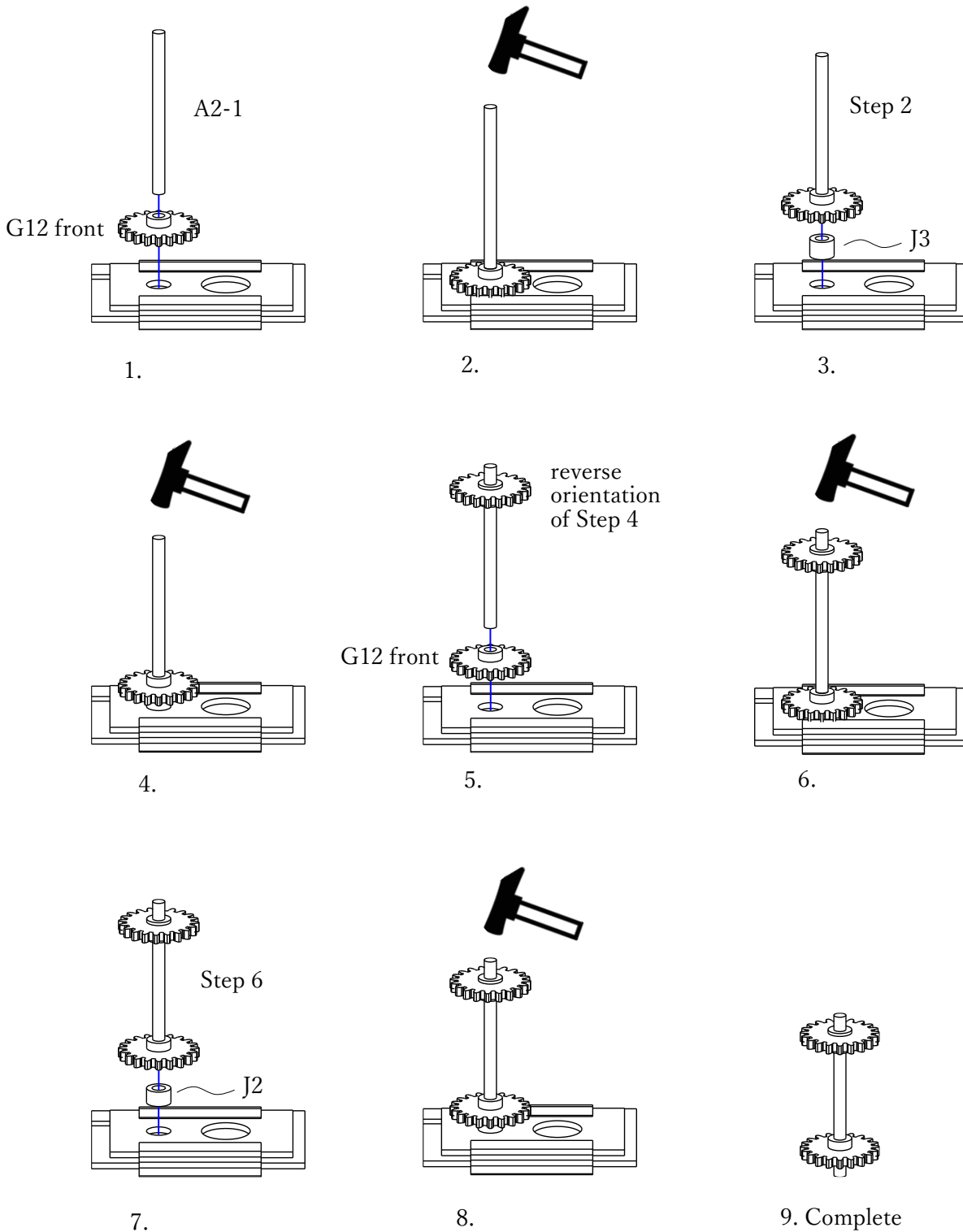

GA8 : Venus Drive Gear

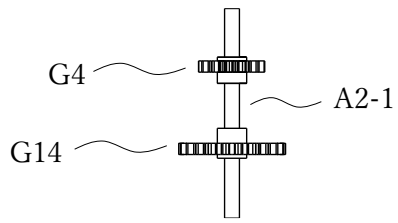

Completed View

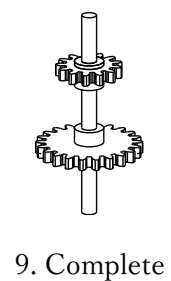
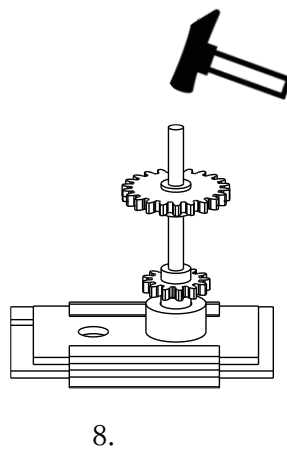
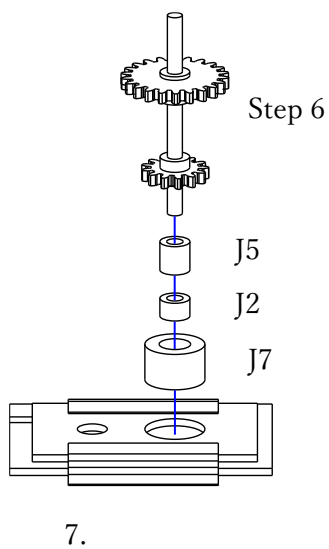
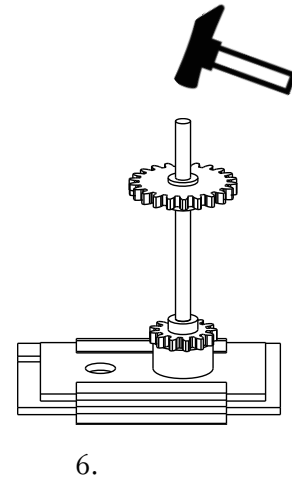
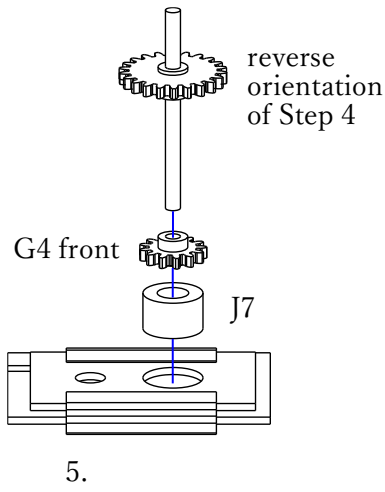
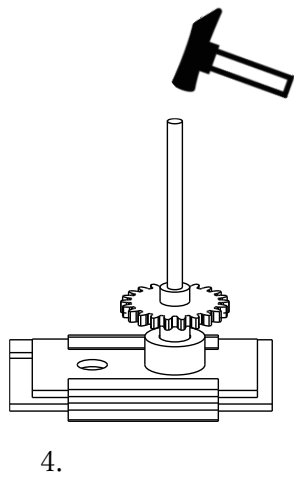
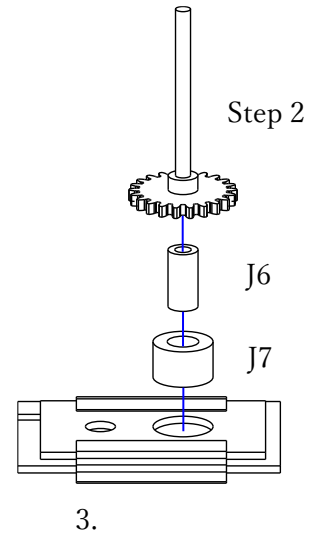
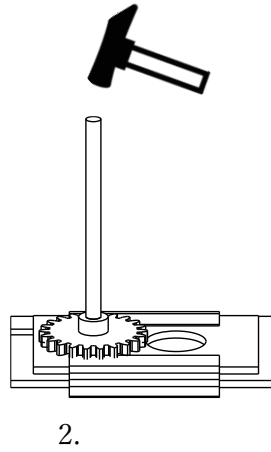
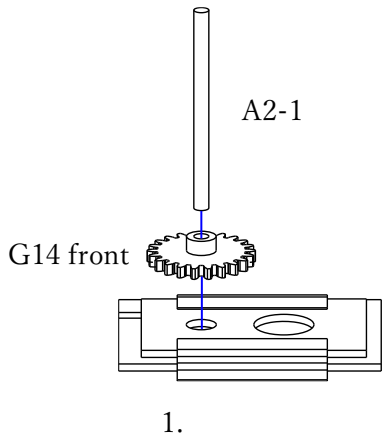

GA9 : Mars Drive Gear

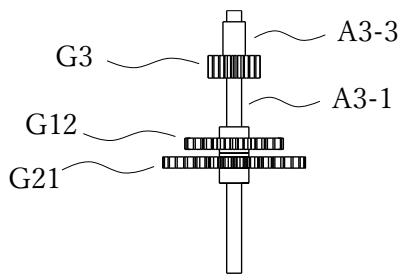

Completed View

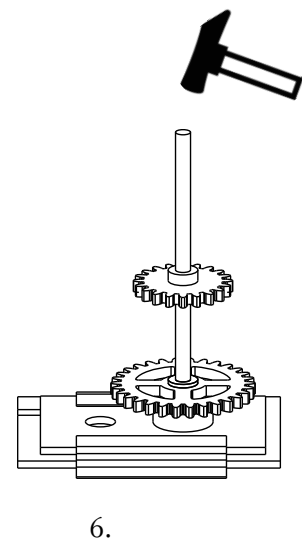
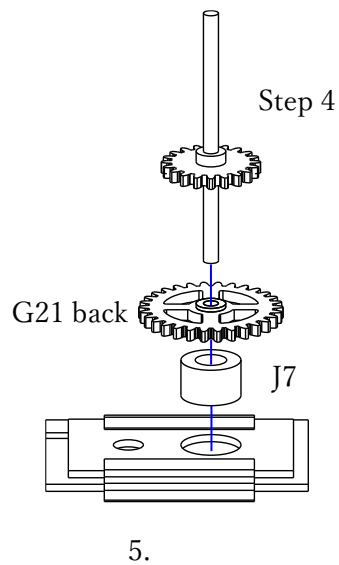
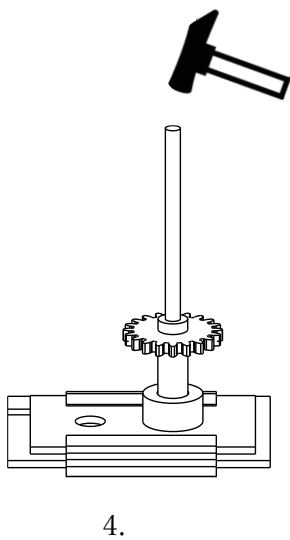
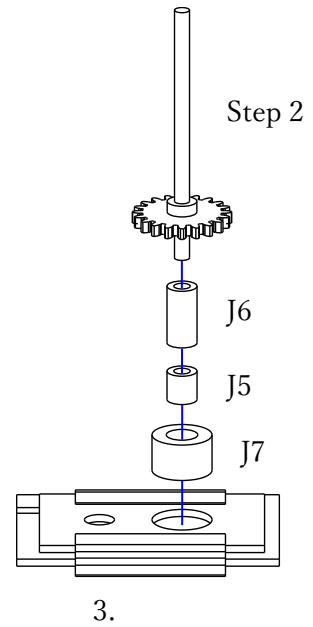
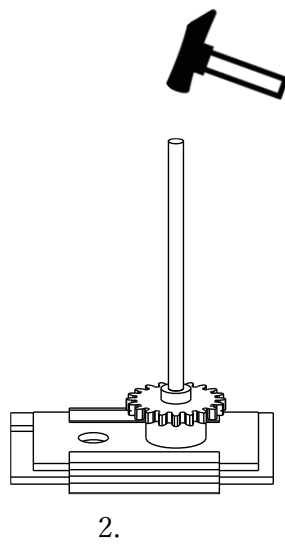
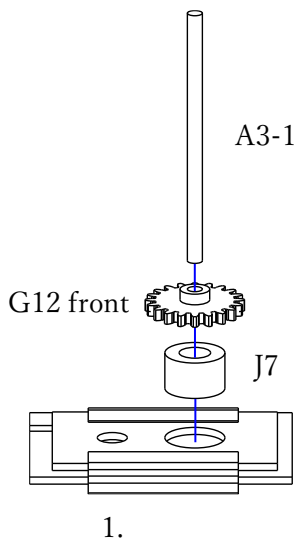

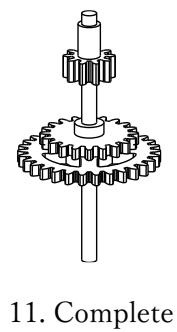
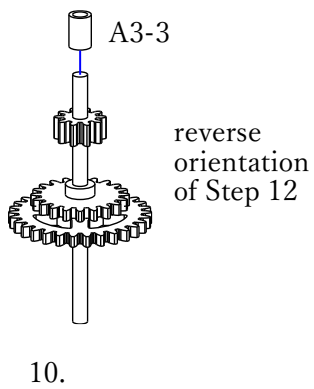
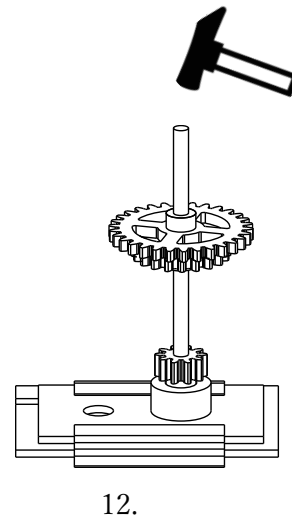
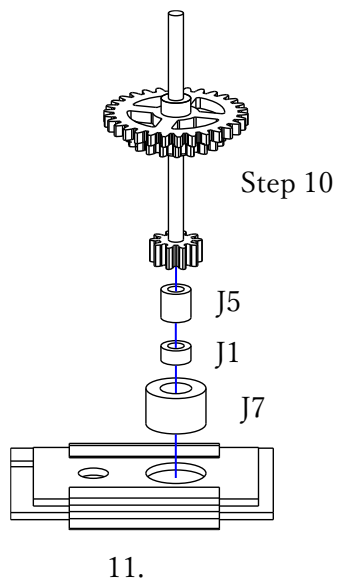
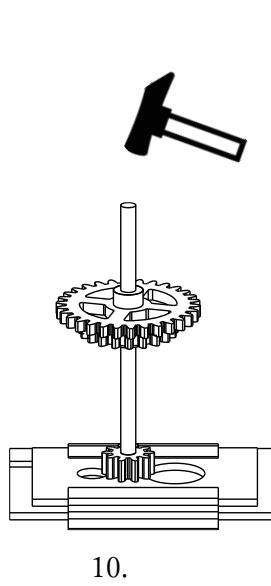
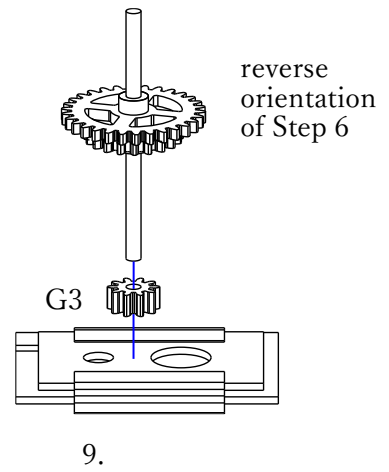
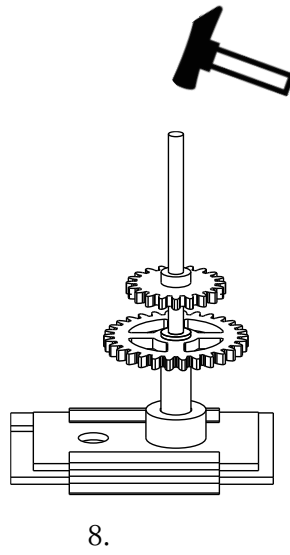
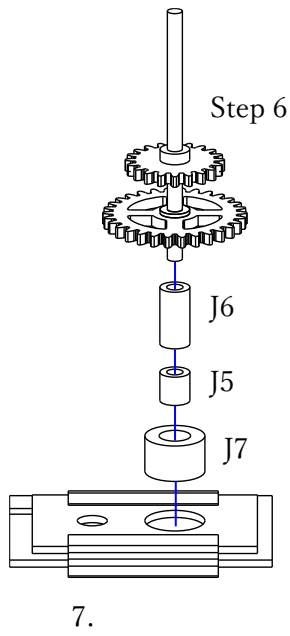

GA10 : Lunar Phase Drive Gear

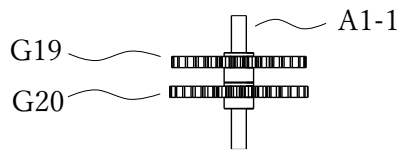

Completed View

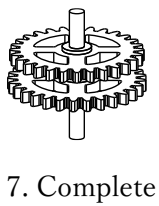
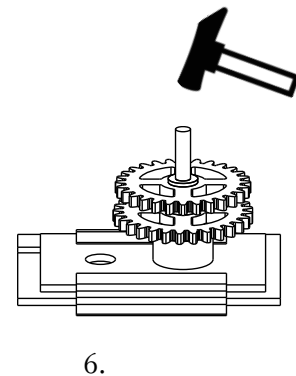
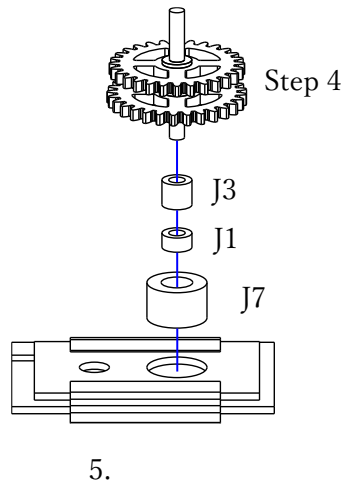
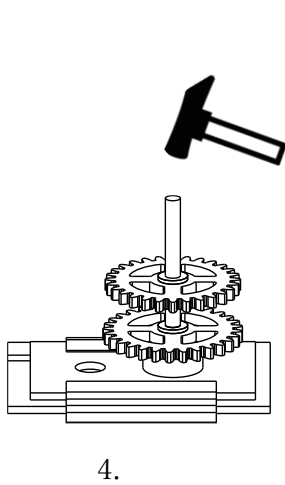
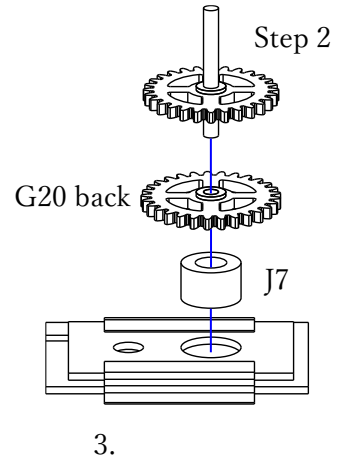
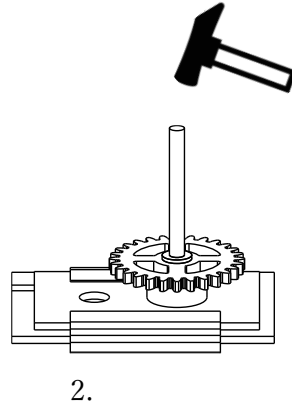
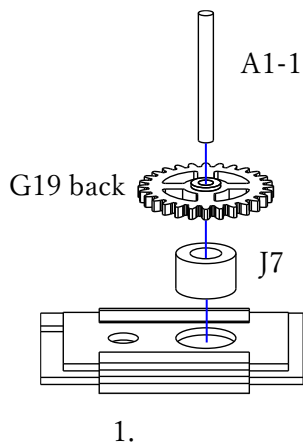

GA11 : Lunar Phase Gear

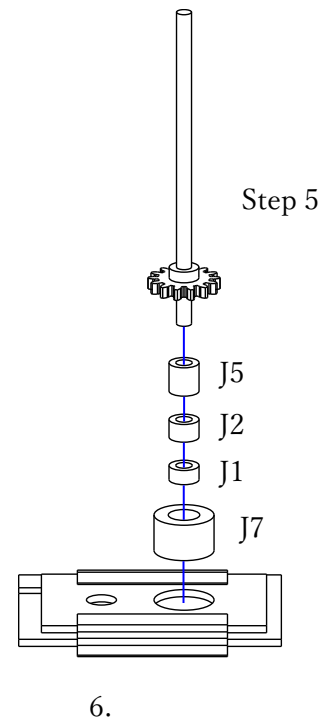
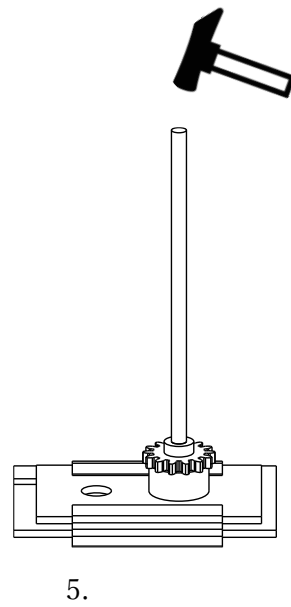
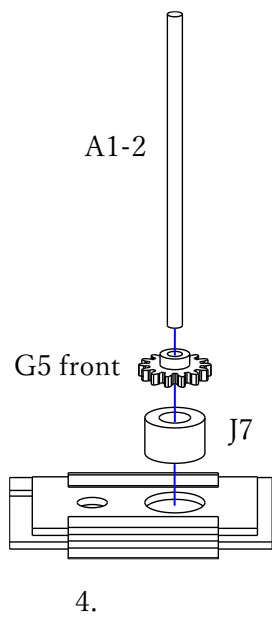
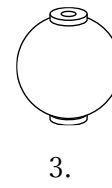
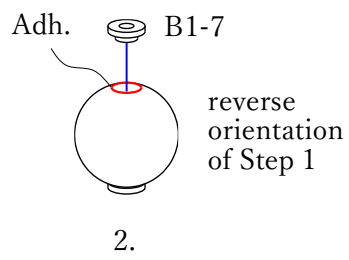
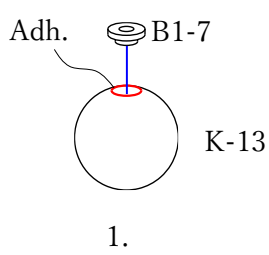
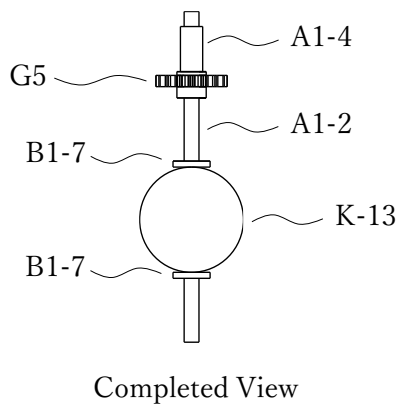

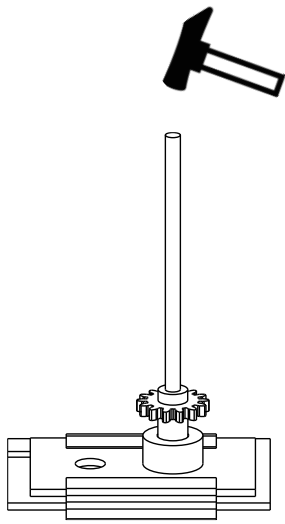

7.

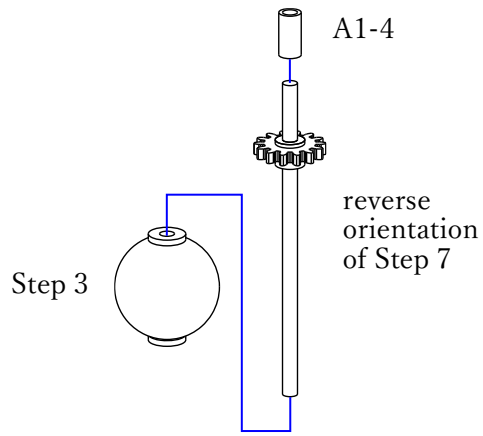

8. Wait for the adhesive from Step 3 to dry, then insert it into the shaft.
It is normal for it to move freely and slide downward in the shaft, as the orientation from Step 3 will be adjusted in later steps.

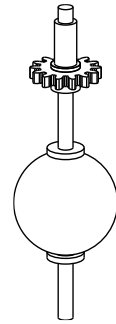

9. Complete

GA12 : Saturn Drive System Gear 1

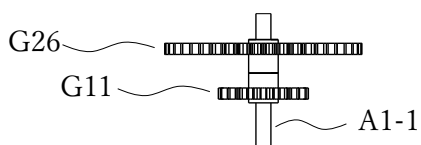

Completed View

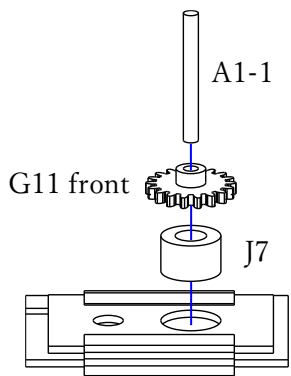

1.

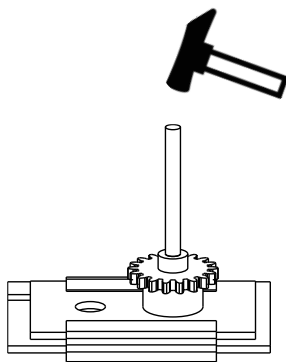

2.

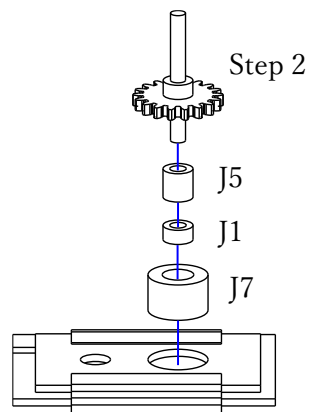

3.

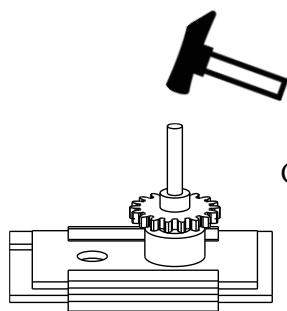

4.

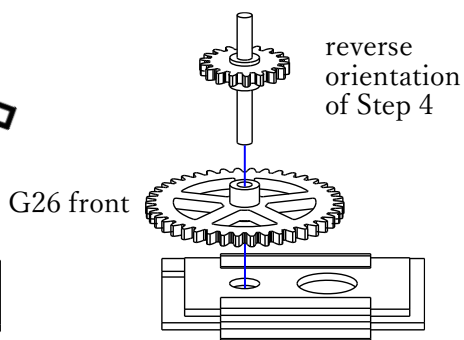

5.

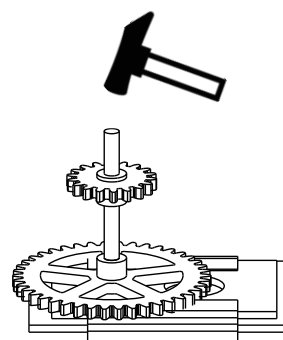

6.

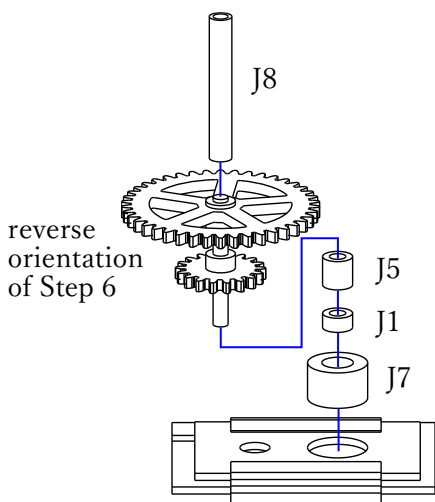

7.

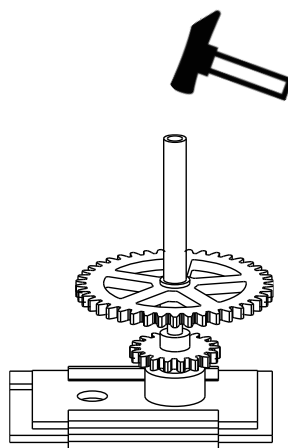

8.

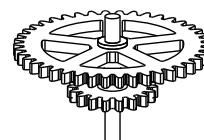

9. Complete

GA13 : Saturn Drive System Gear 2

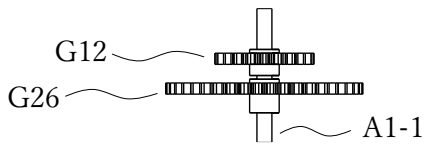

Completed View

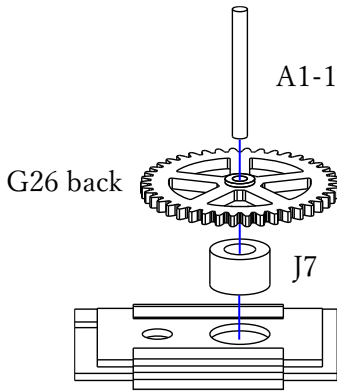

1.

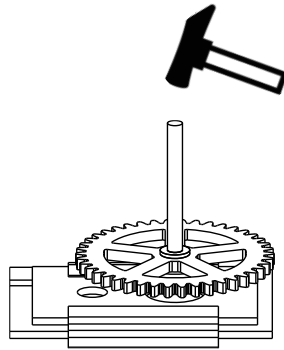

2.

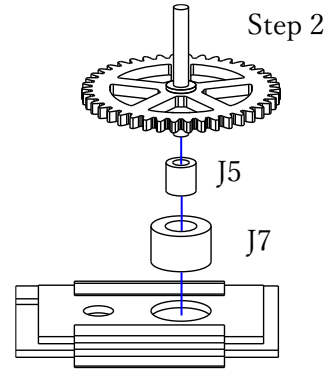

3.

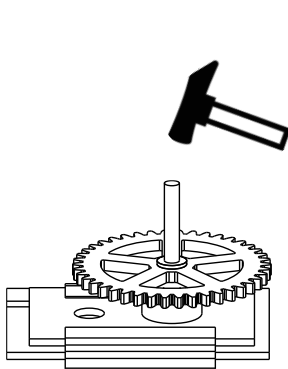

4.

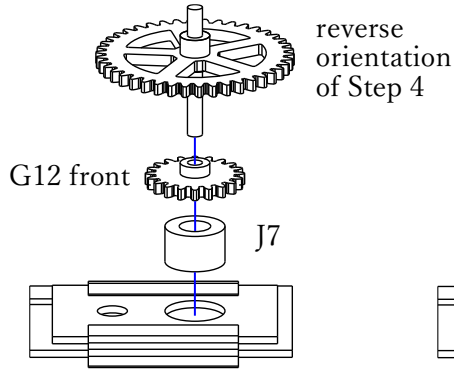

5.

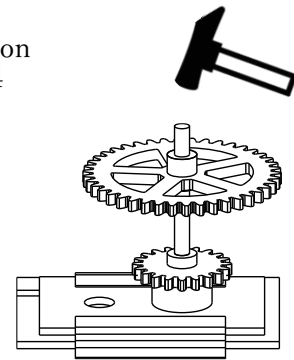

6.

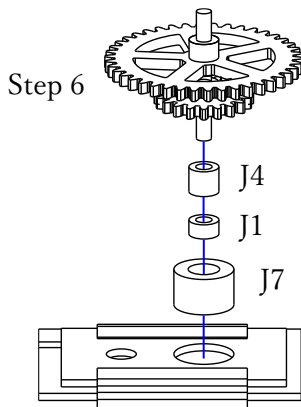

7.

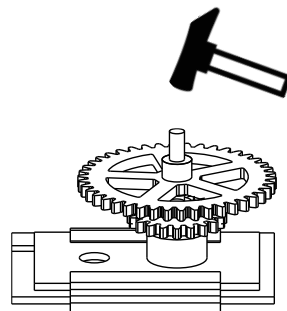

8.

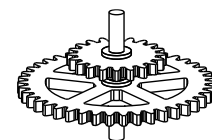

9. Complete

GA14 : Saturn Drive Gear

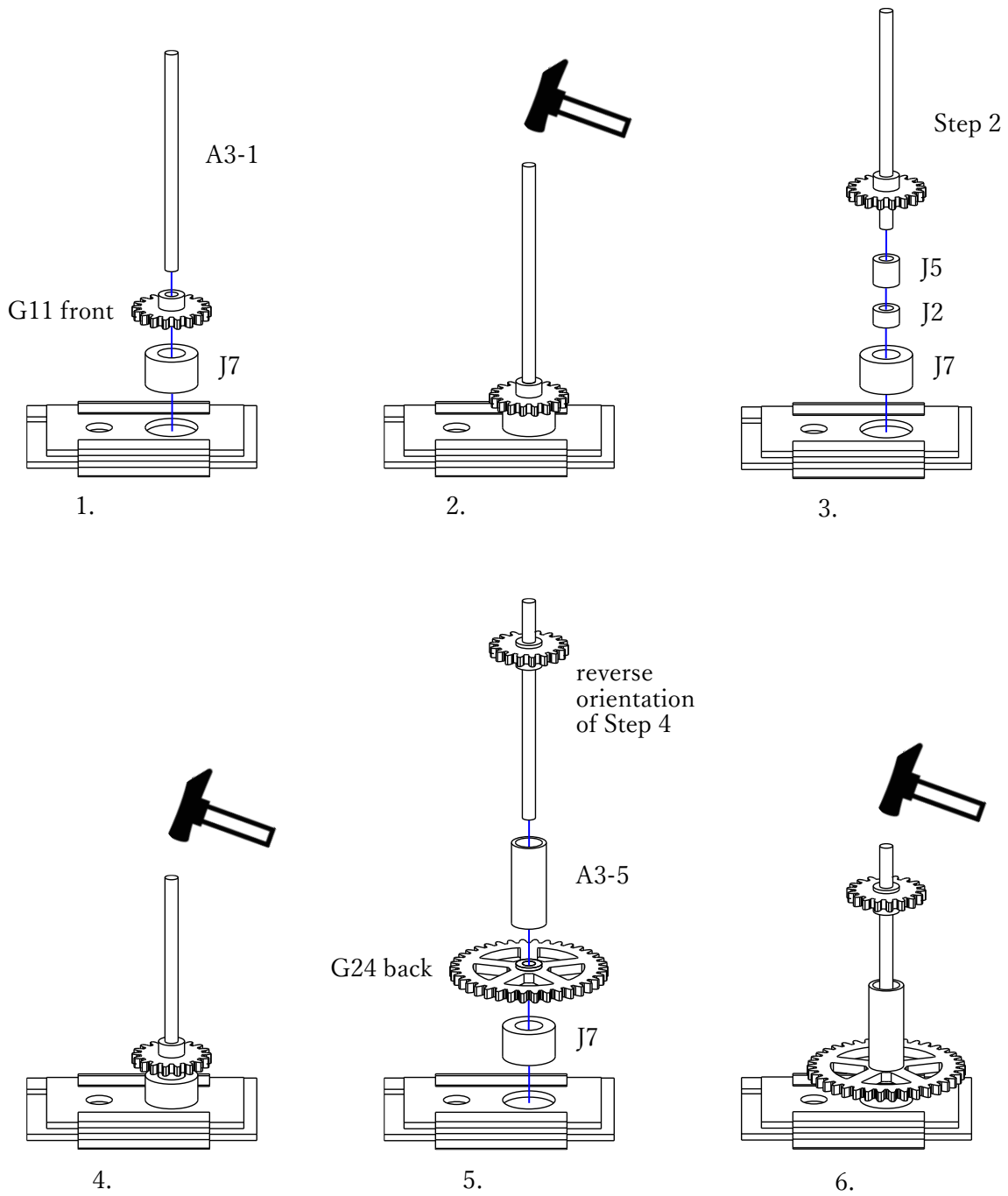
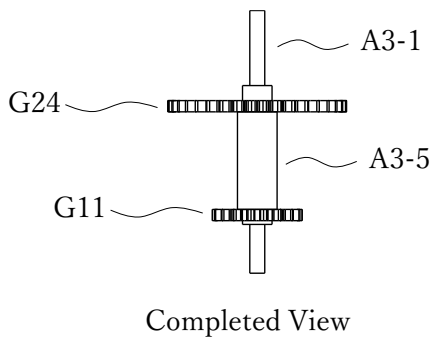

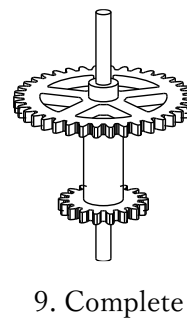
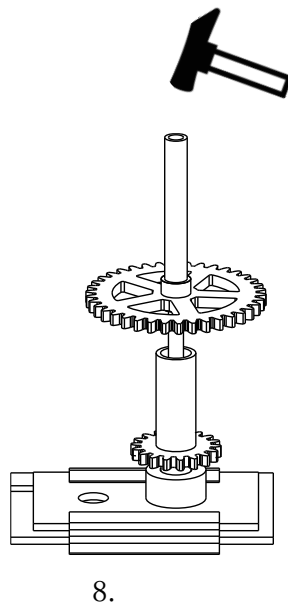
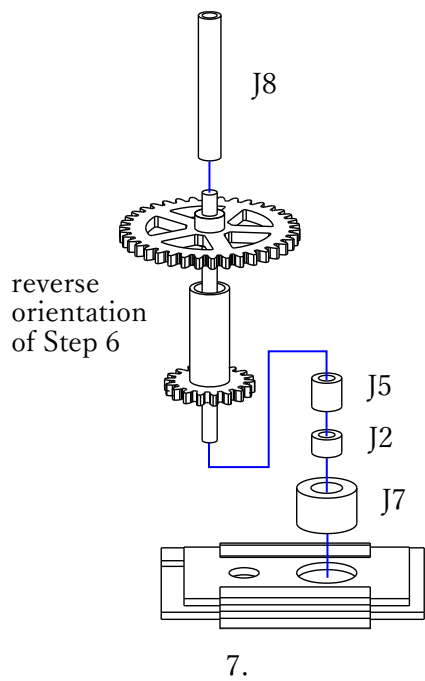

GA15 : Uranus Drive System Gear

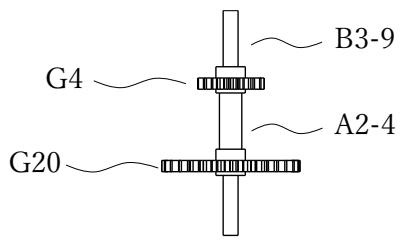

Completed View

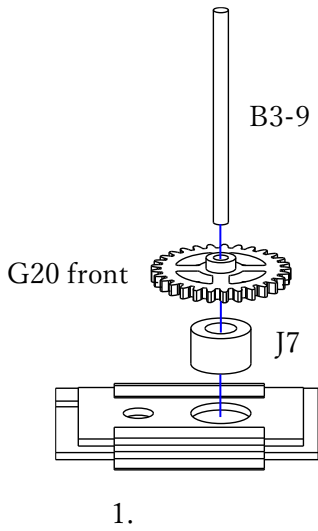

1.

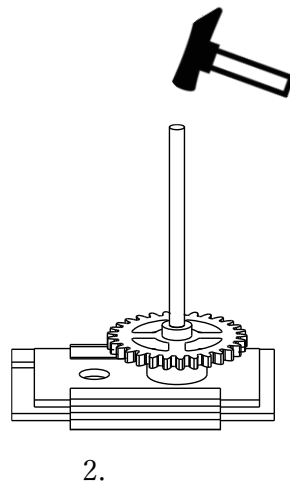

2.

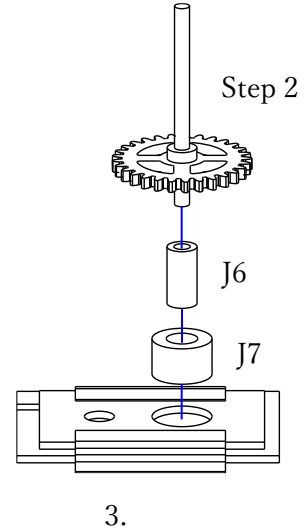

3.

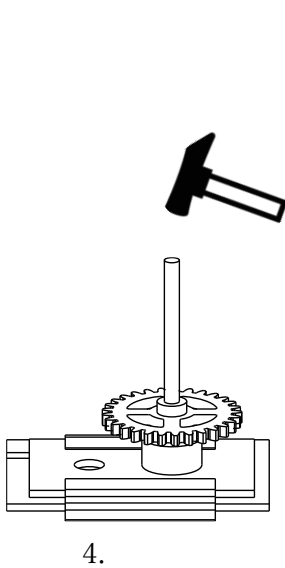

4.

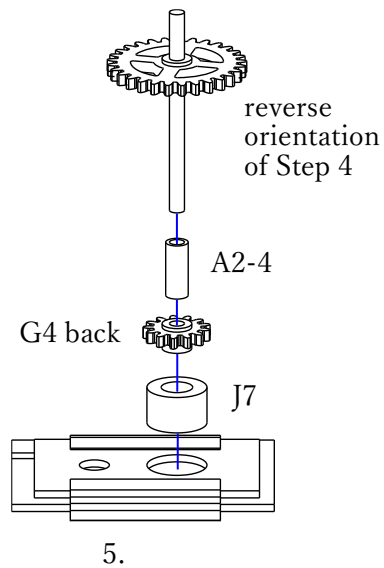

5.

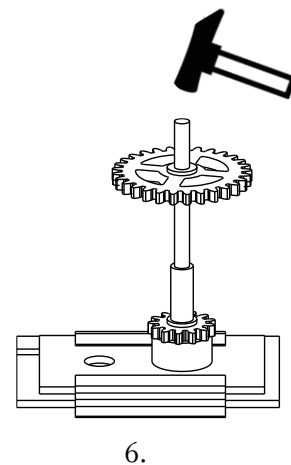

6.

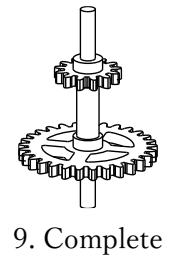
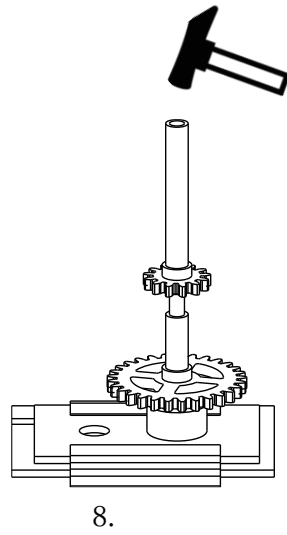
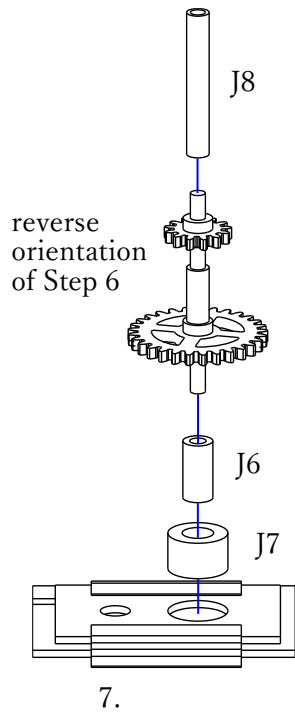

GA16 : Uranus Drive Gear

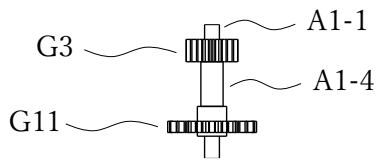

Completed View

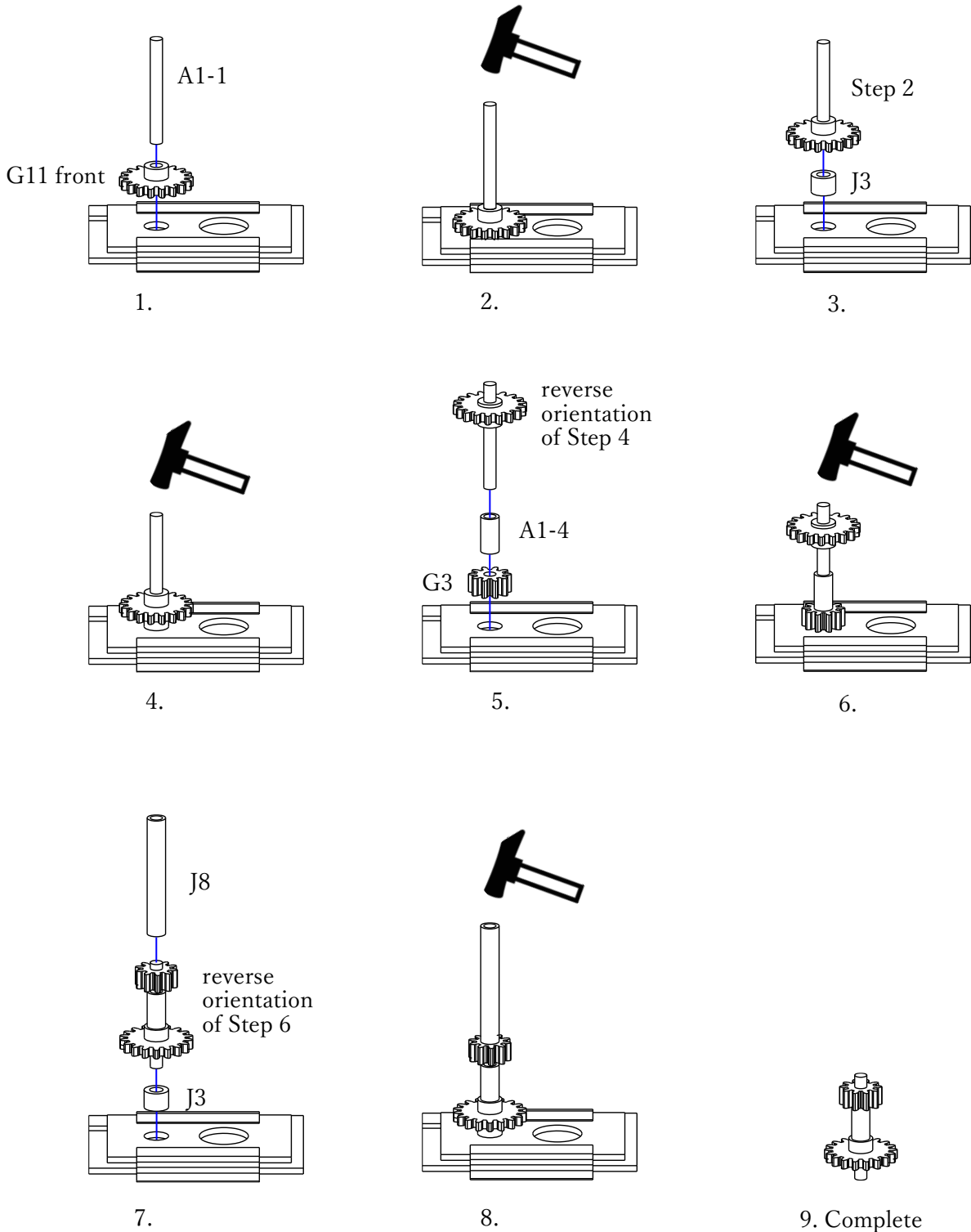

GA17 : Time Scale Coupling Gear

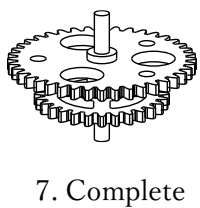
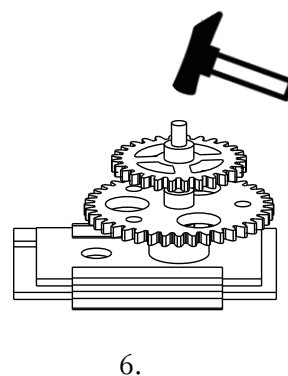
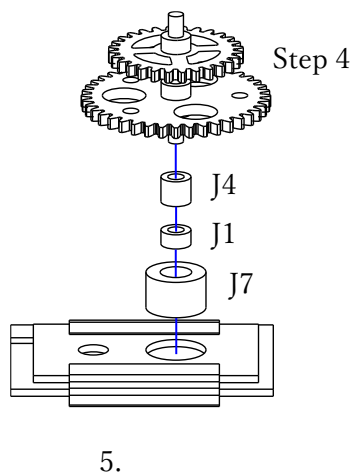
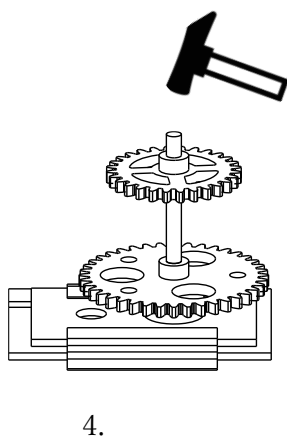
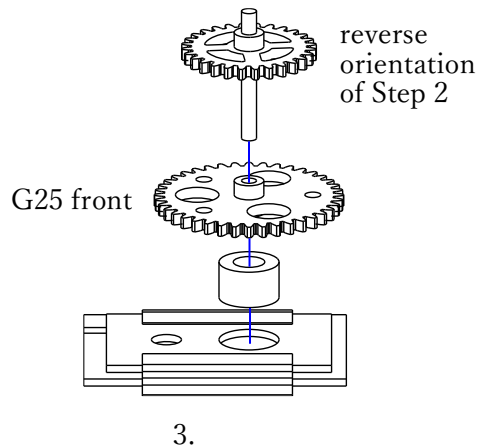
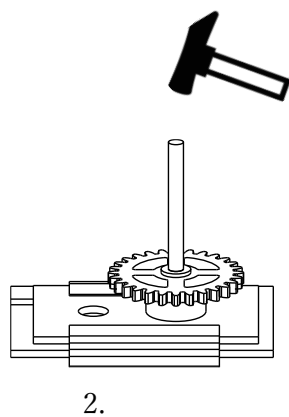
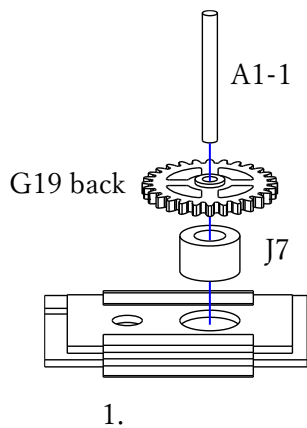
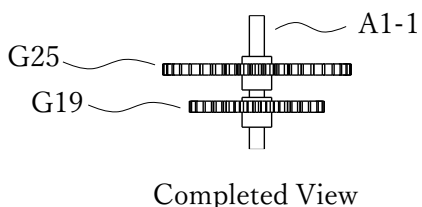

GA18 : Moon Drive System Gear 1

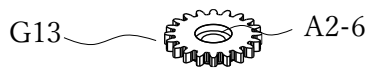

Completed View

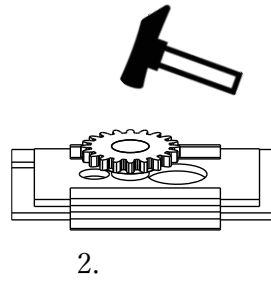
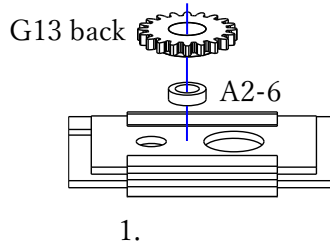

GA19 : Month Gear

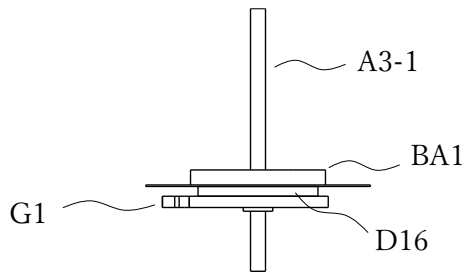

Completed View

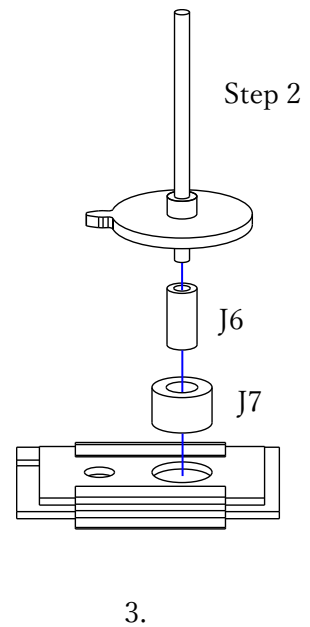
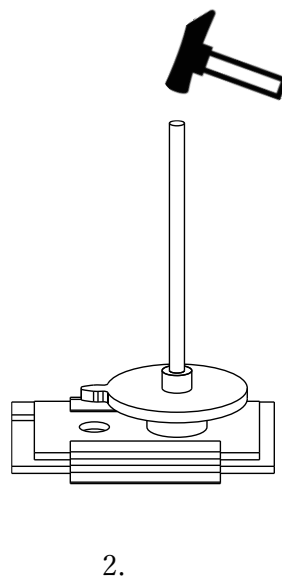
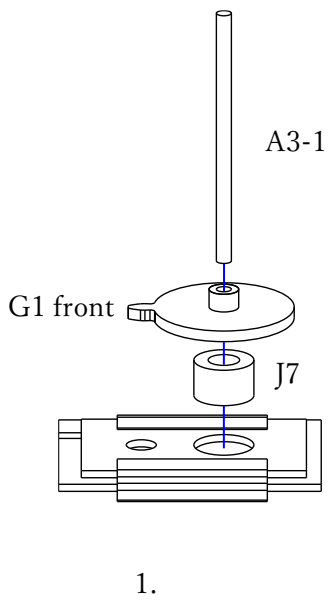

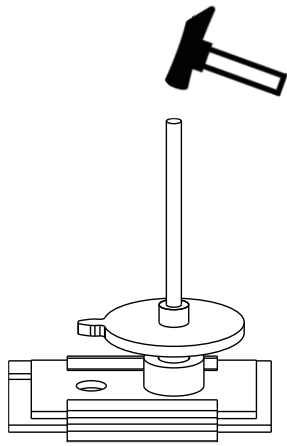

4.

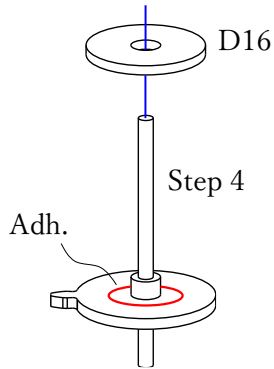

5.

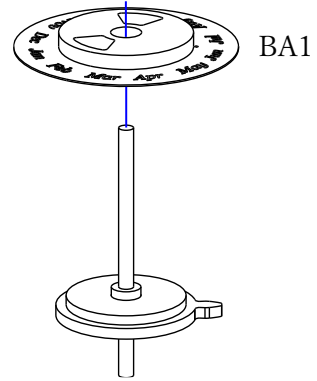

6.

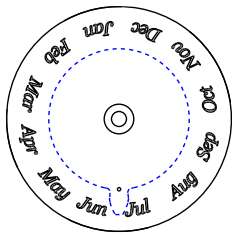

7. Rotate BA1 so that the center of the gear tooth aligns with the midpoint between “Jun” and “Jul.”

Keep BA1 free to move for fine adjustment in later steps.

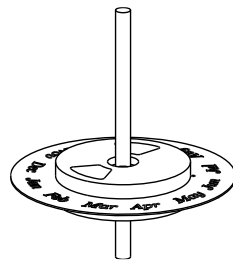

8. Complete

GA20 : Years Drive Gear

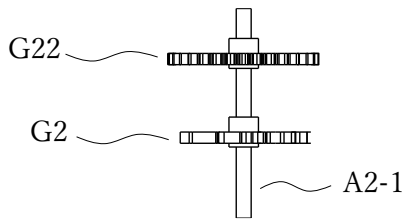

Completed View

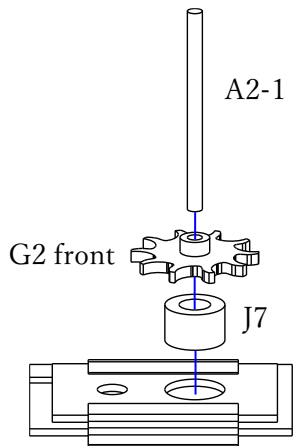

1.

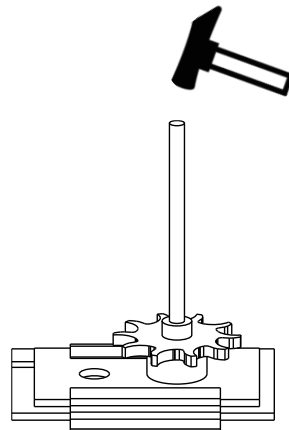

2.

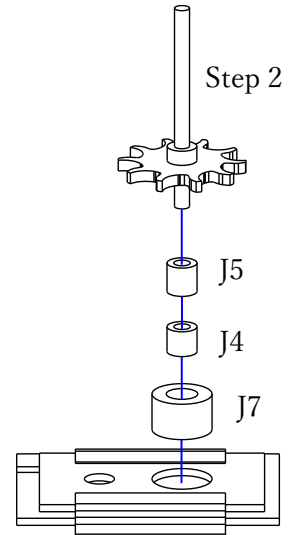

3.

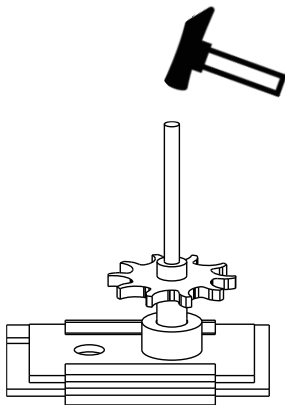

4.

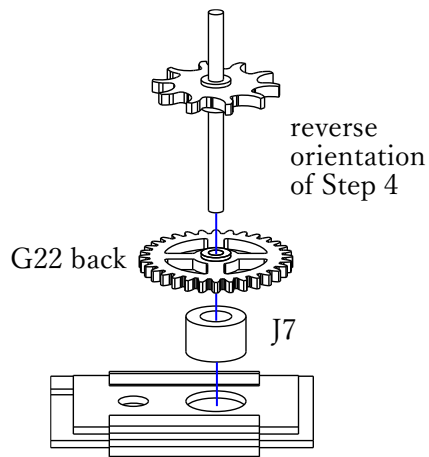

5.

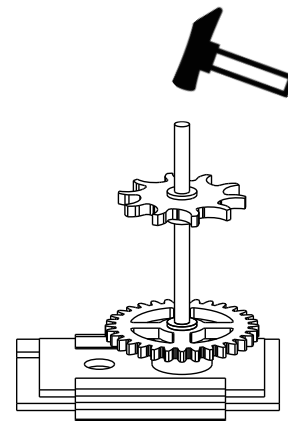

6.

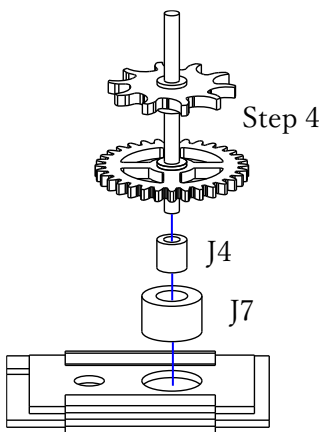

7.

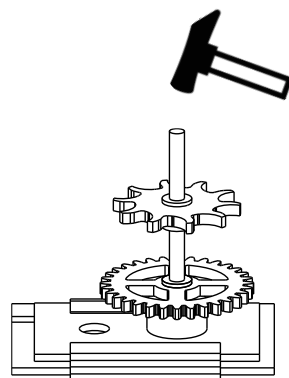

8.

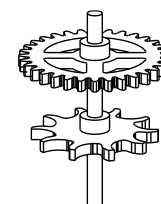

9. Complete

GA21 : Years Gear

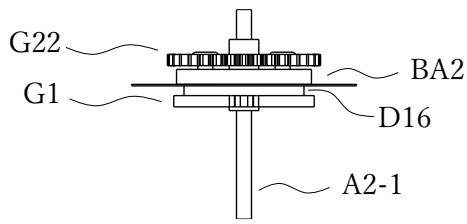

Completed View

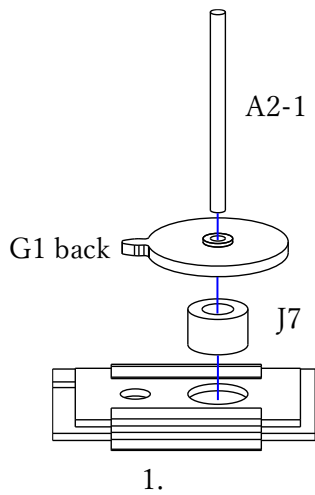

1.

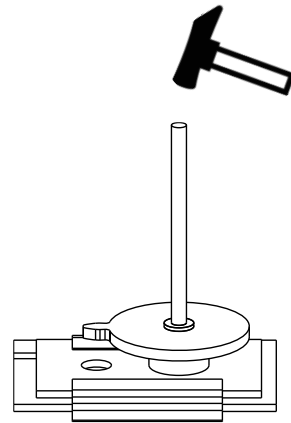

2.

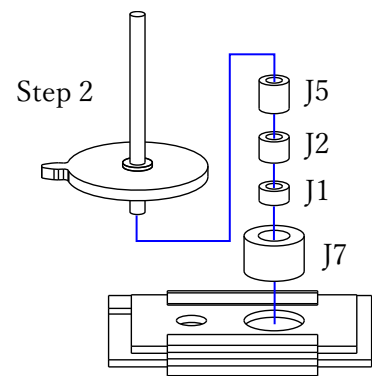

3.

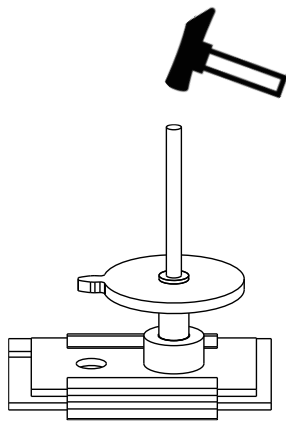

4.

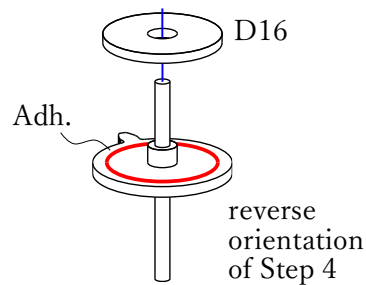

5.

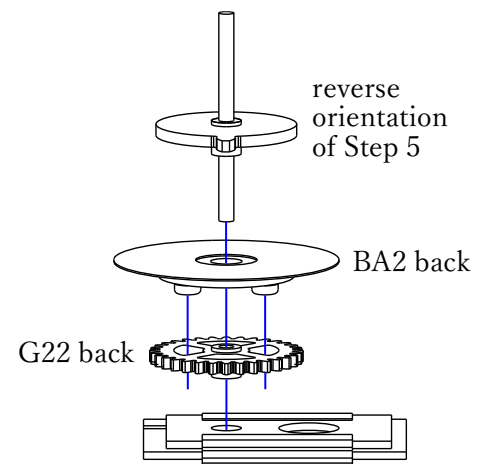

6. Refer to Step 10 for the correct mounting orientation of each part.

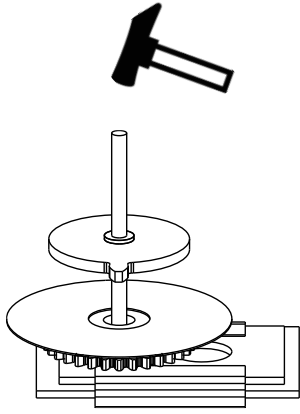

7. Ensure BA2 does not move and push the screw out of G22 while hammering the shaft.

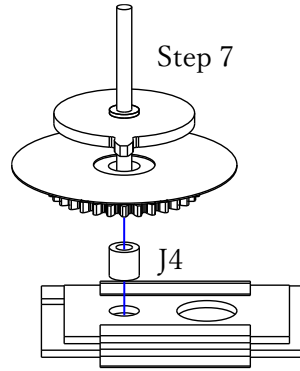

8.

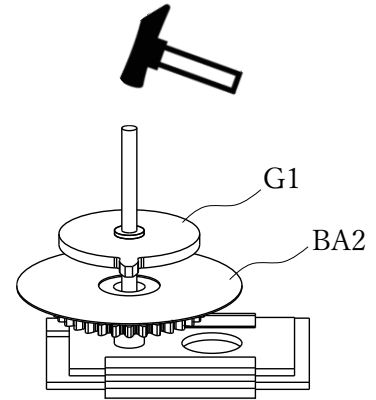

9. Hammer little by little until G1 is very close to BA2 but not touching.

(If they touch and BA2 can no longer rotate freely, adjust it in Step 10.)

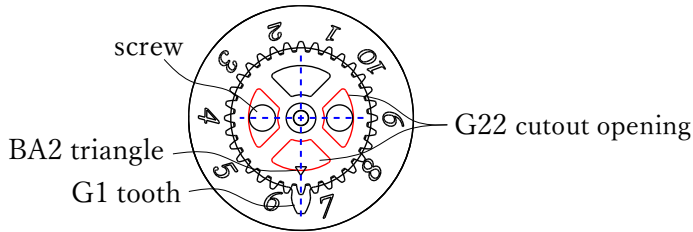

10. Align the center of the G1 tooth, the triangle mark on BA2, and the center of the gear's cutout opening in G22. After Step 9, turn G22 and BA2 by hand to fine-tune the alignment. (The G1 tooth cannot be seen from the view in the diagram—check from the side.)

If BA2 does not rotate freely, grip the lower shaft from Step 11 with pliers and slightly twist G22 away from BA2 while lifting it upward in small increments. Then readjust the alignment as above.

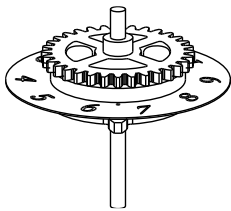

11. Complete

GA22 : 10 years Drive Gear

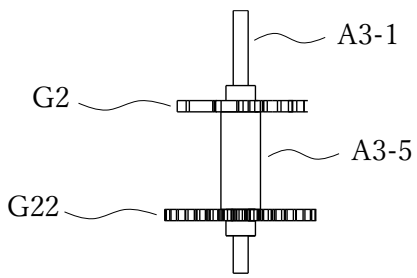

Completed View

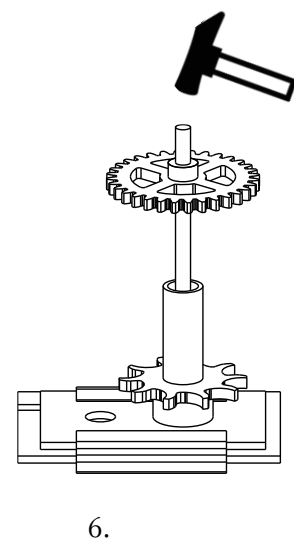
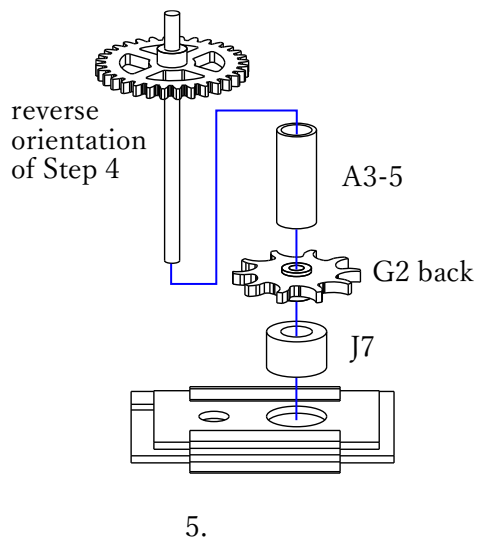
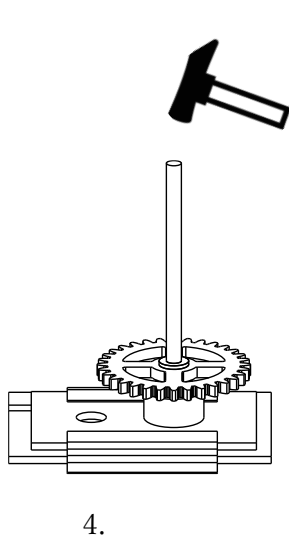
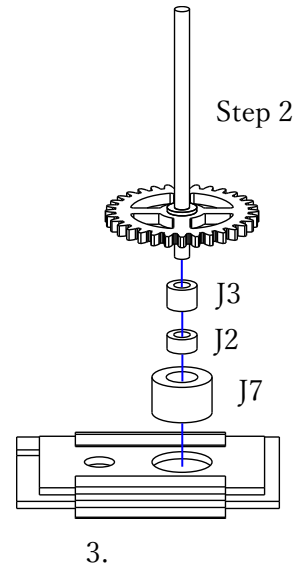
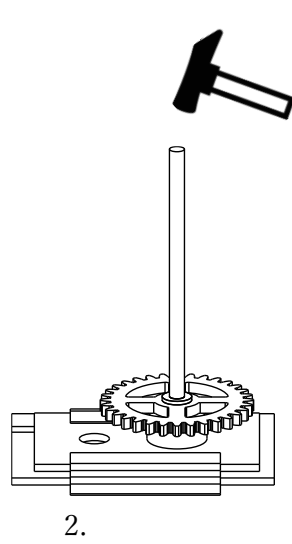
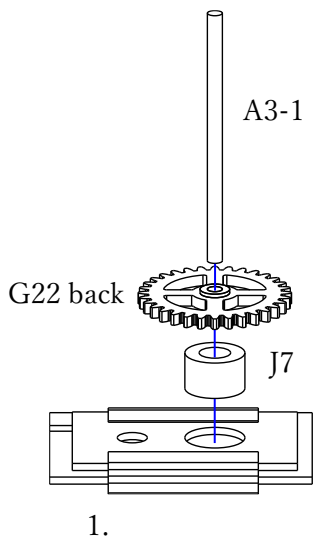

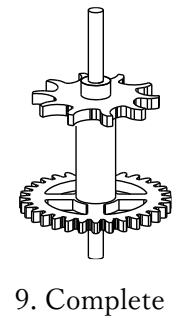
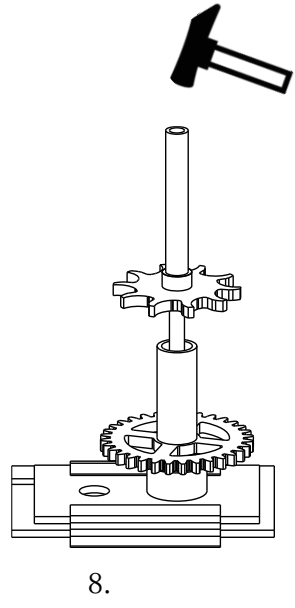
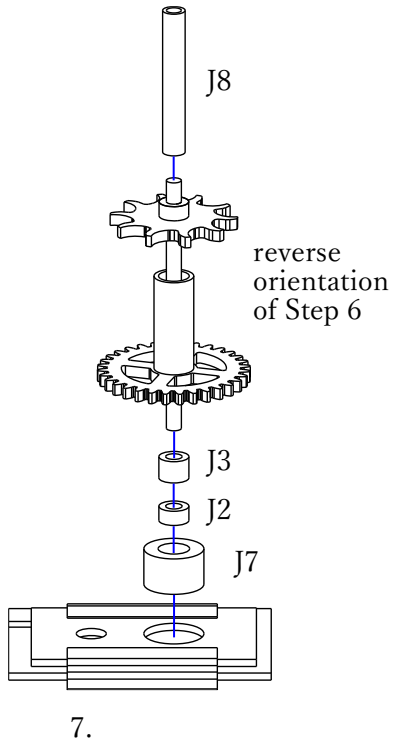

GA23 : 10 years Gear

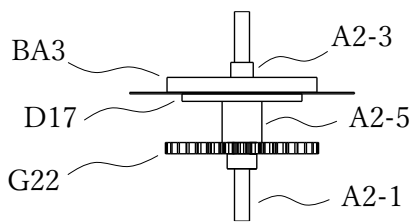

Completed View

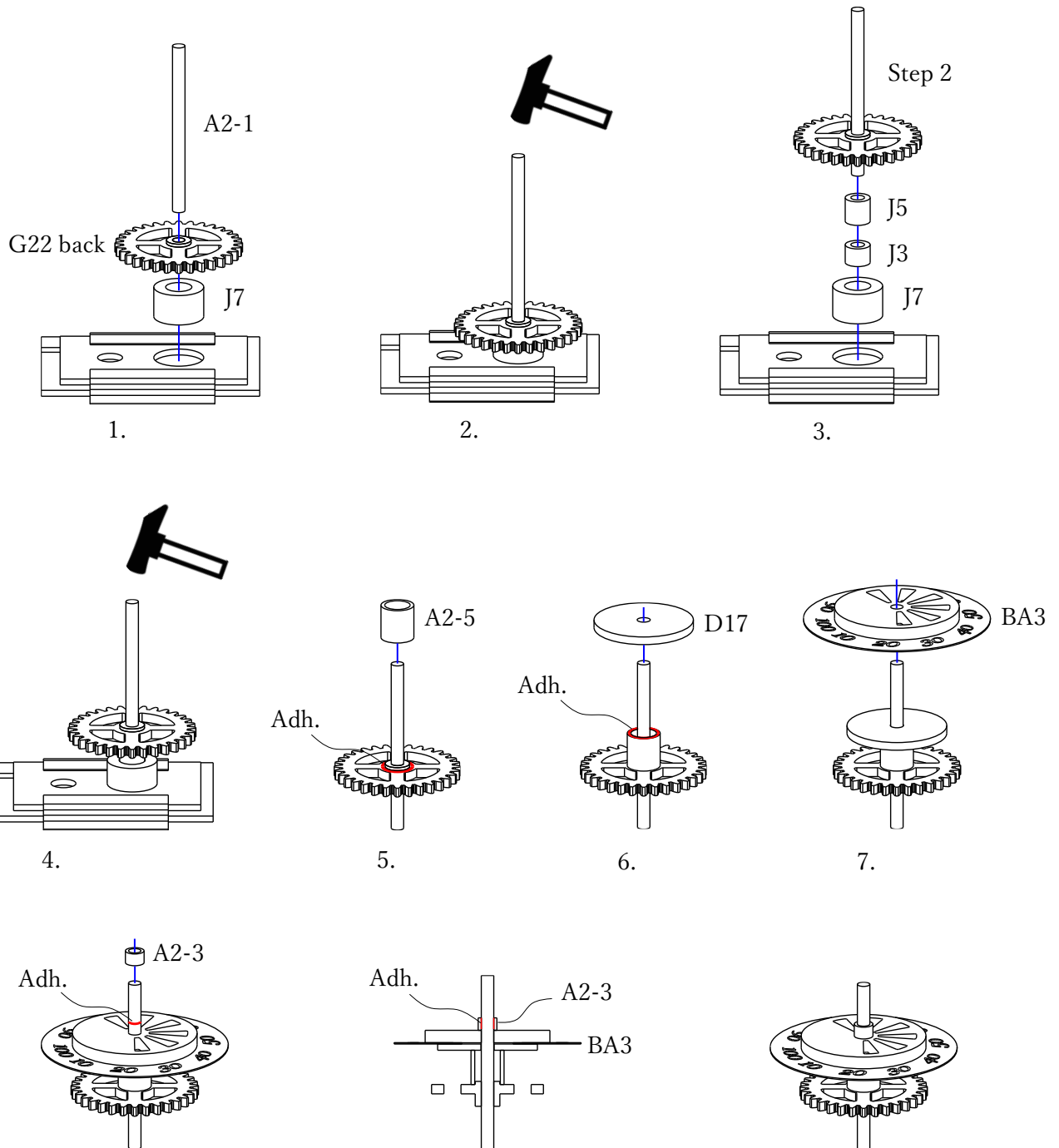

8. After bonding A2-3 and once the adhesive has dried, hold BA3 and rotate it around the shaft to break any unwanted adhesion between BA3 and the excess adhesive beneath A2-3, ensuring BA3 rotates freely.

GA24 : Neptune Drive System Gear 1

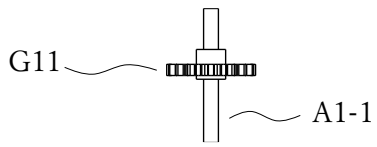

Completed View

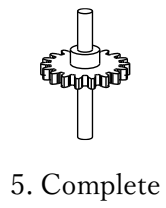
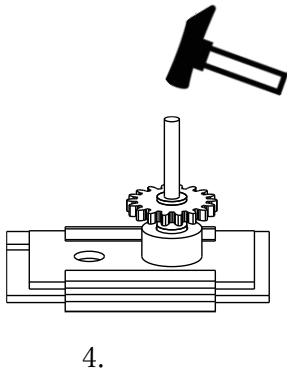
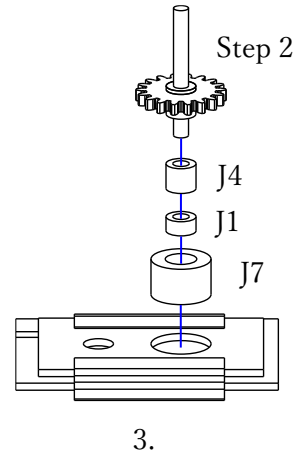
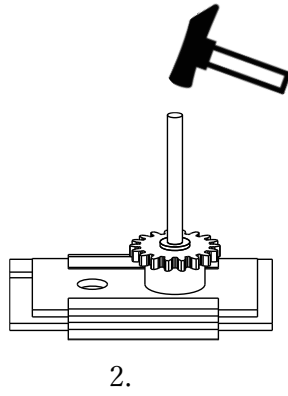
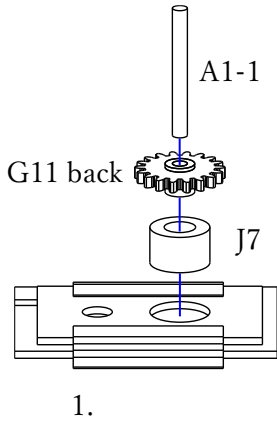

GA25 : Neptune Drive System Gear 2

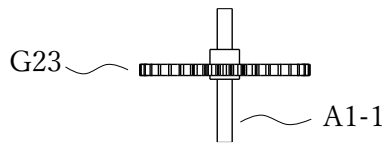

Completed View

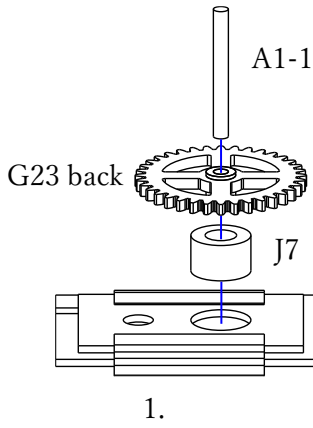

1.

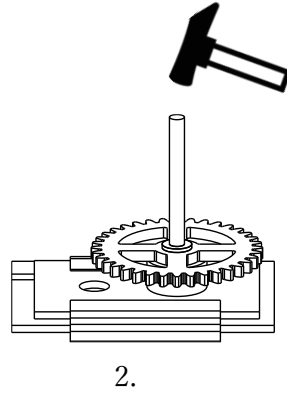

2.

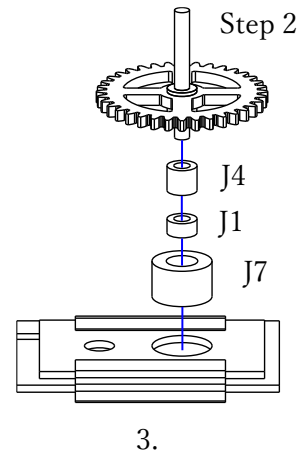

3.

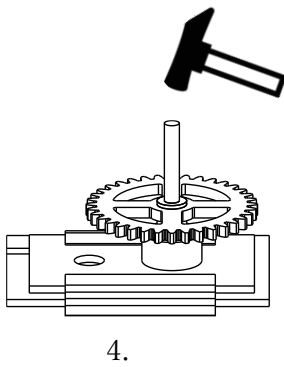

4.

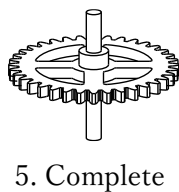

5. Complete

GA26 : Neptune Drive Gear

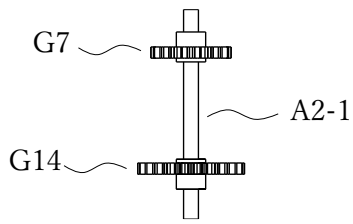

Completed View

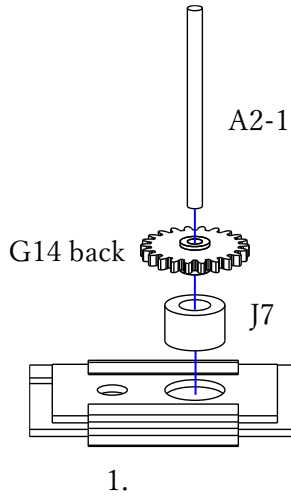

1.

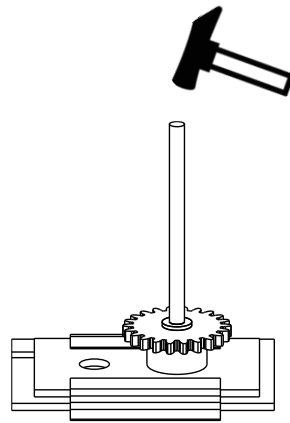

2.

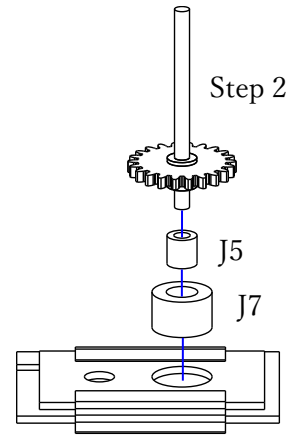

3.

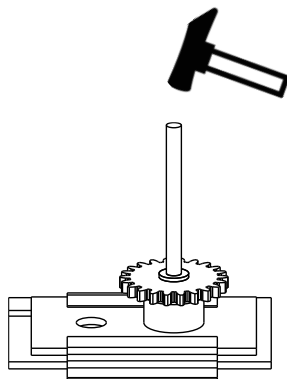

4.

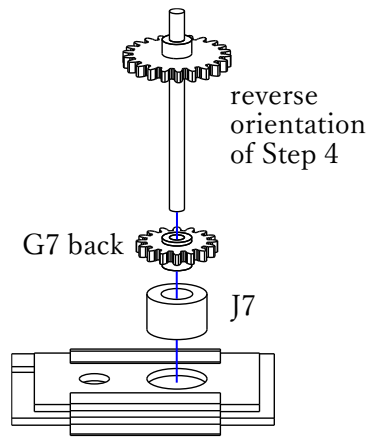

5.

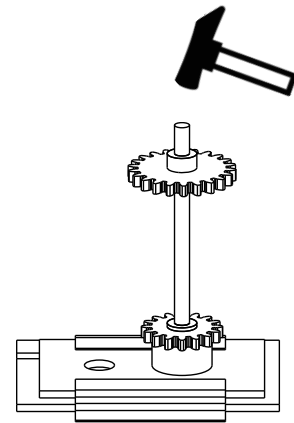

6.

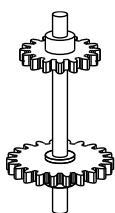

7. Complete

GA27 : Neptune Gear

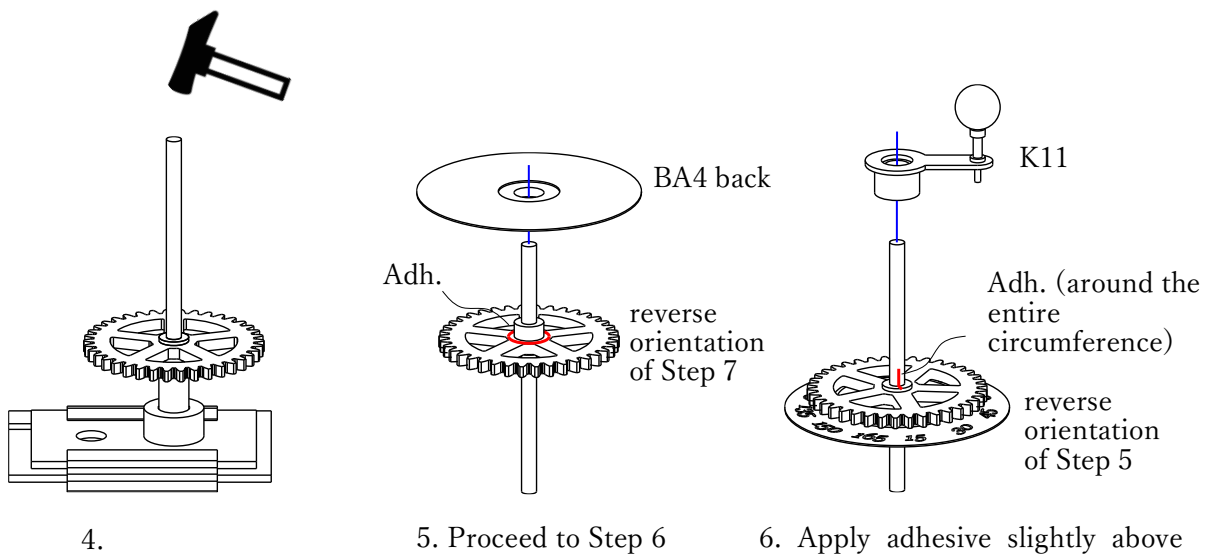
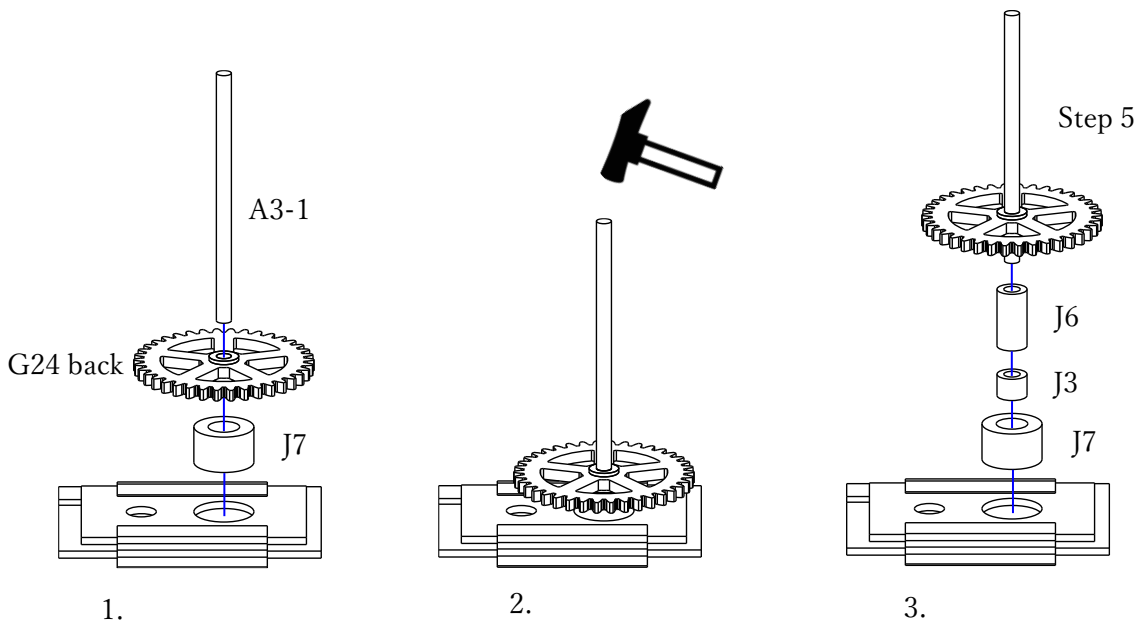
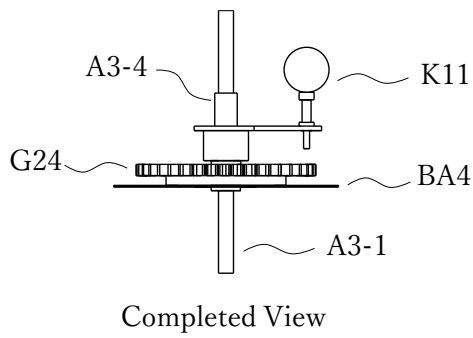

5. Proceed to Step 6 only after the adhesive has fully cured.

6. Apply adhesive slightly above the shaft, as shown in the diagram, so that K11 and A3-4 from Step 7 cure together. Perform Steps 6–9 continuously without interruption.

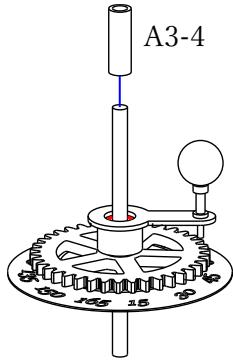

7.

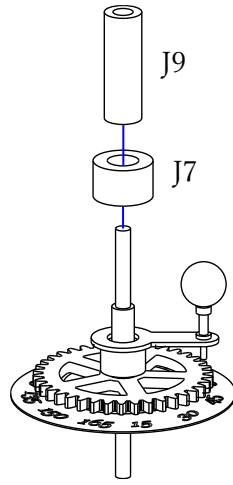

8. Use weights (J7, J9) to keep K11 from tilting while the adhesive cures.

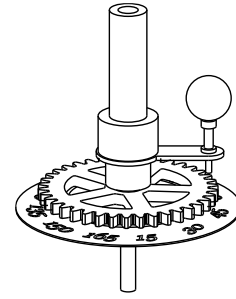

9. Wait until the adhesive has fully cured.

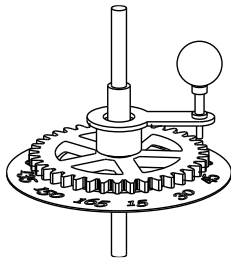

10. Complete

GA28 : Comet Coupling Gear

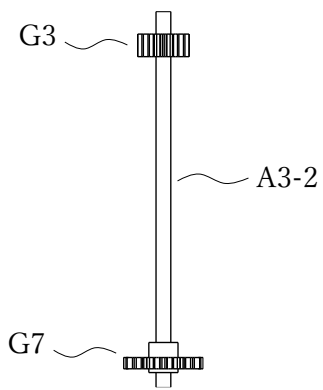

Completed View

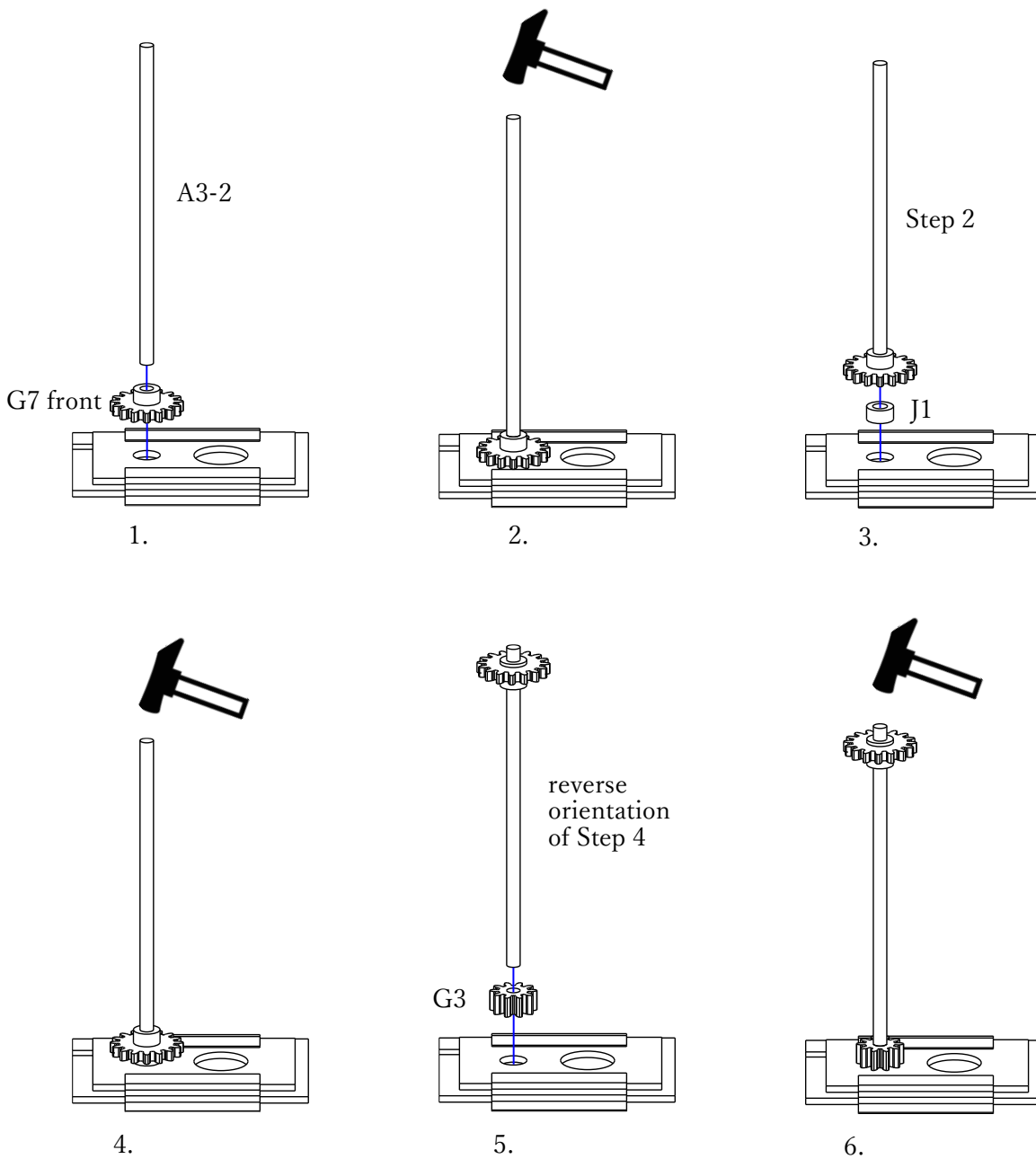

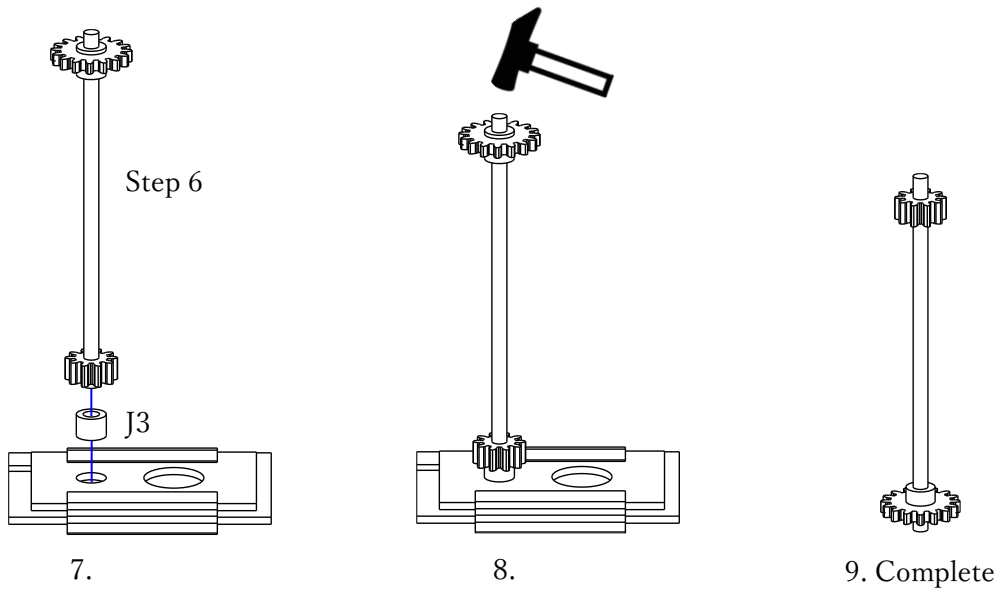

GA29 : Jupiter Orbit Drive System Gear 1

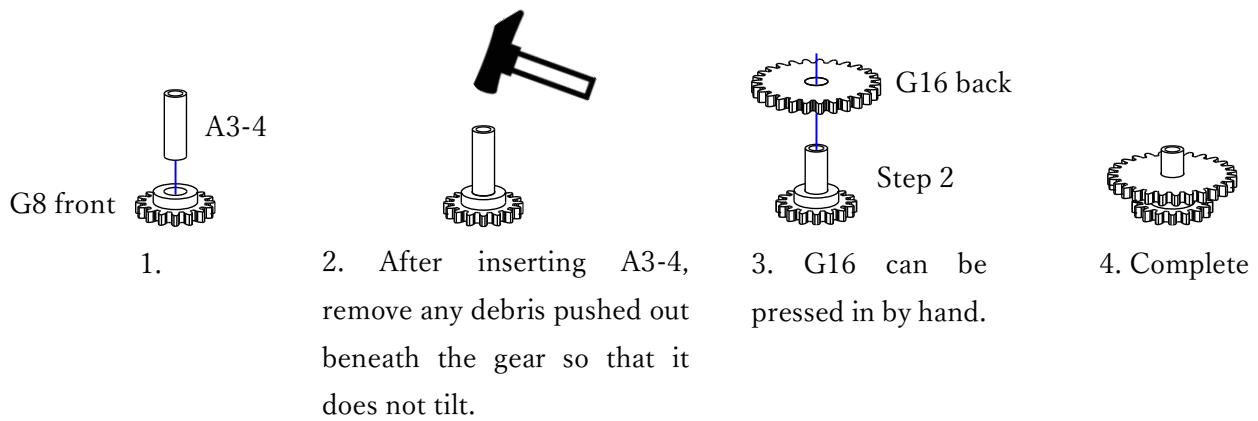
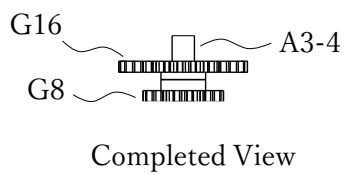

GA30 : Jupiter Orbit Drive System Gear 2

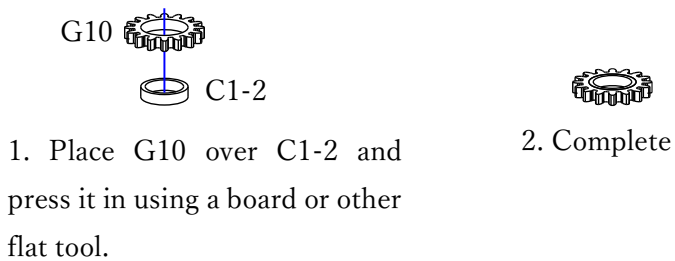
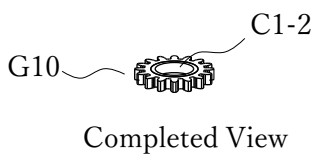

GA31 : Jupiter Orbit Gear

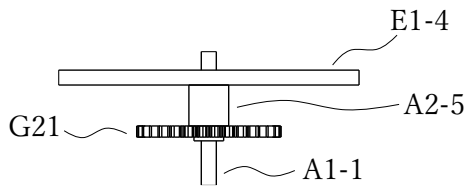

Completed View

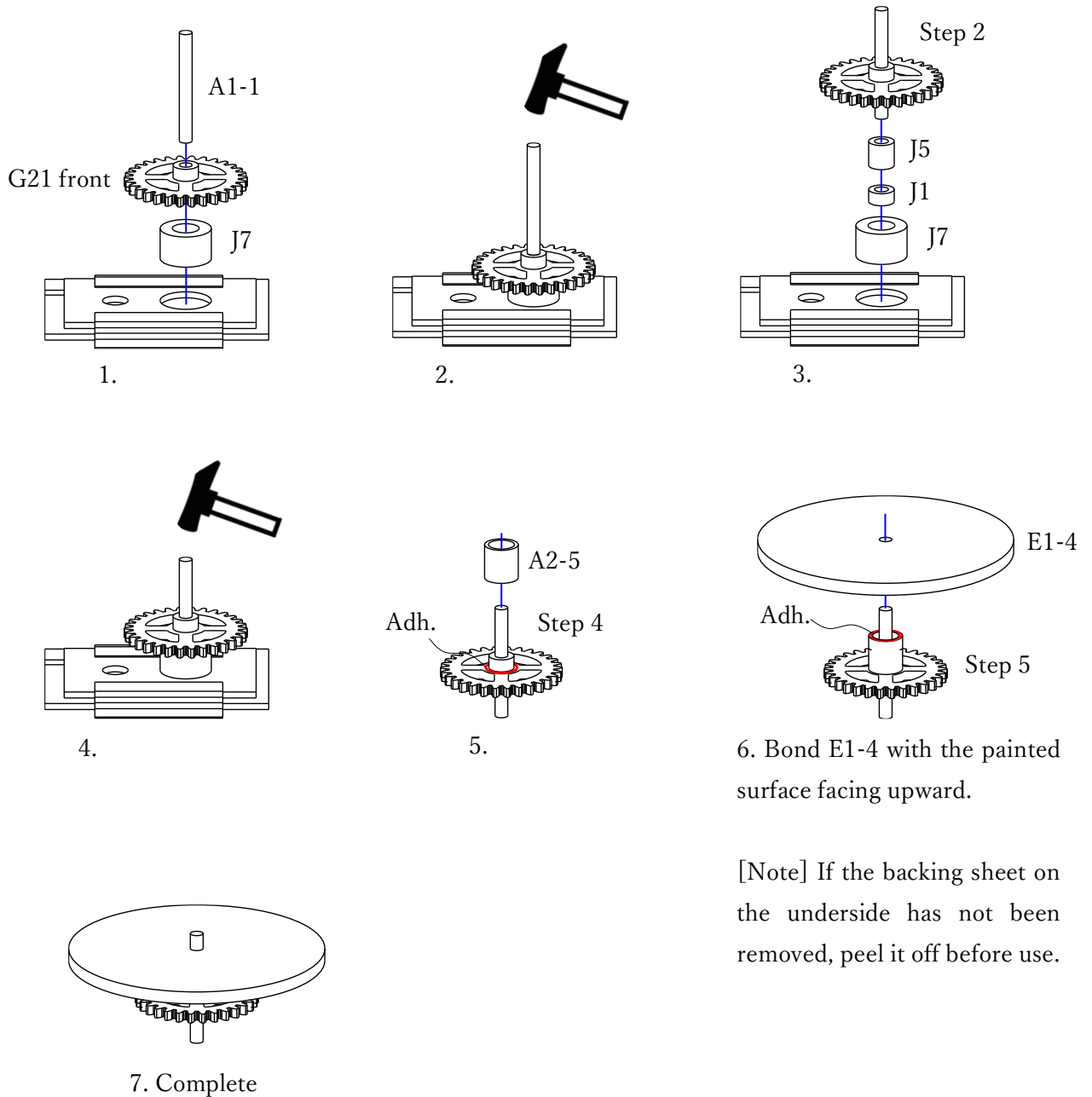

[Note] If the backing sheet on the underside has not been removed, peel it off before use.

GA32 : Comet Drive Gear

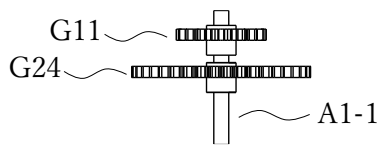

Completed View

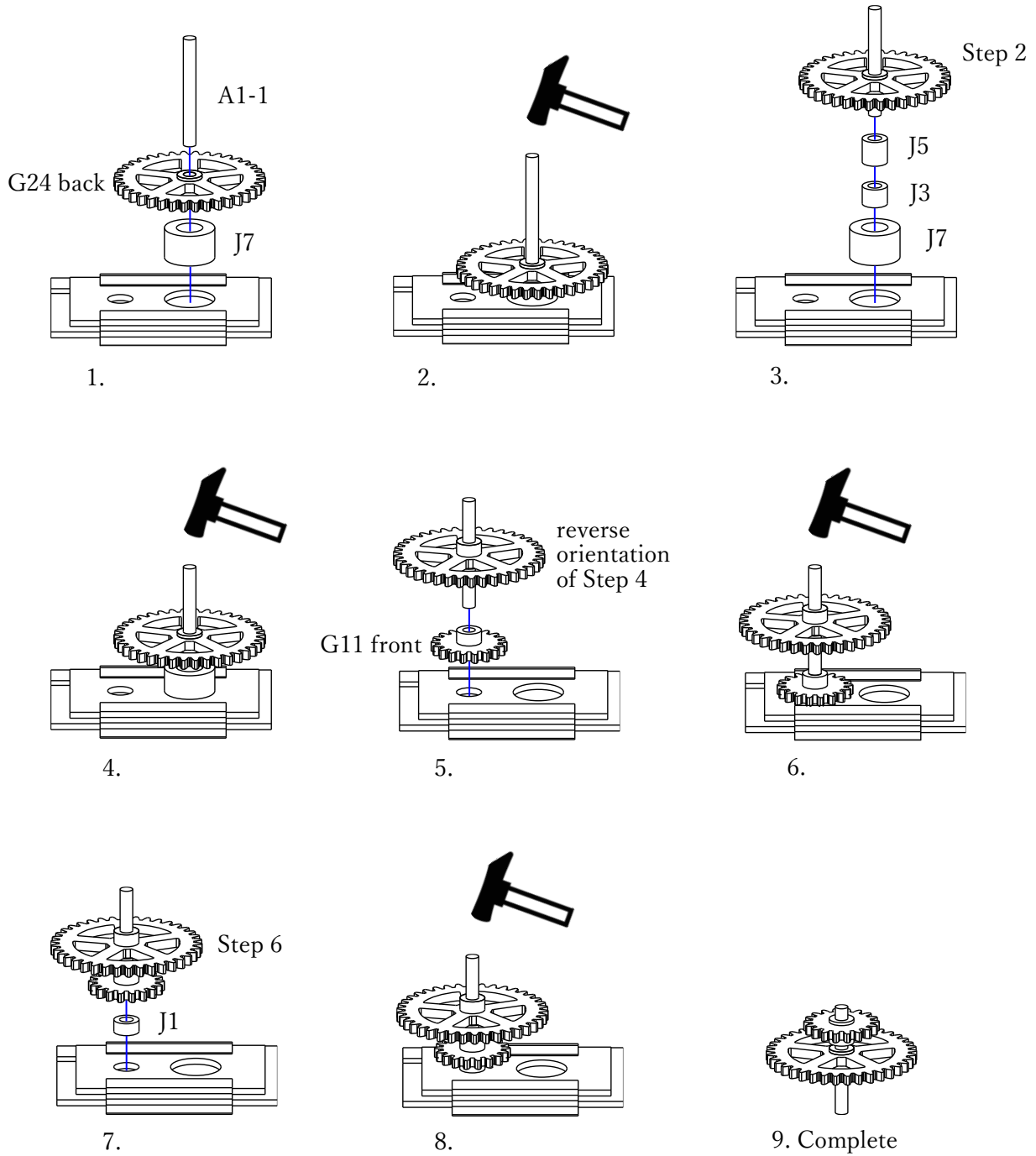

GA33 : Comet Gear

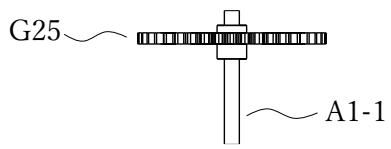

Completed View

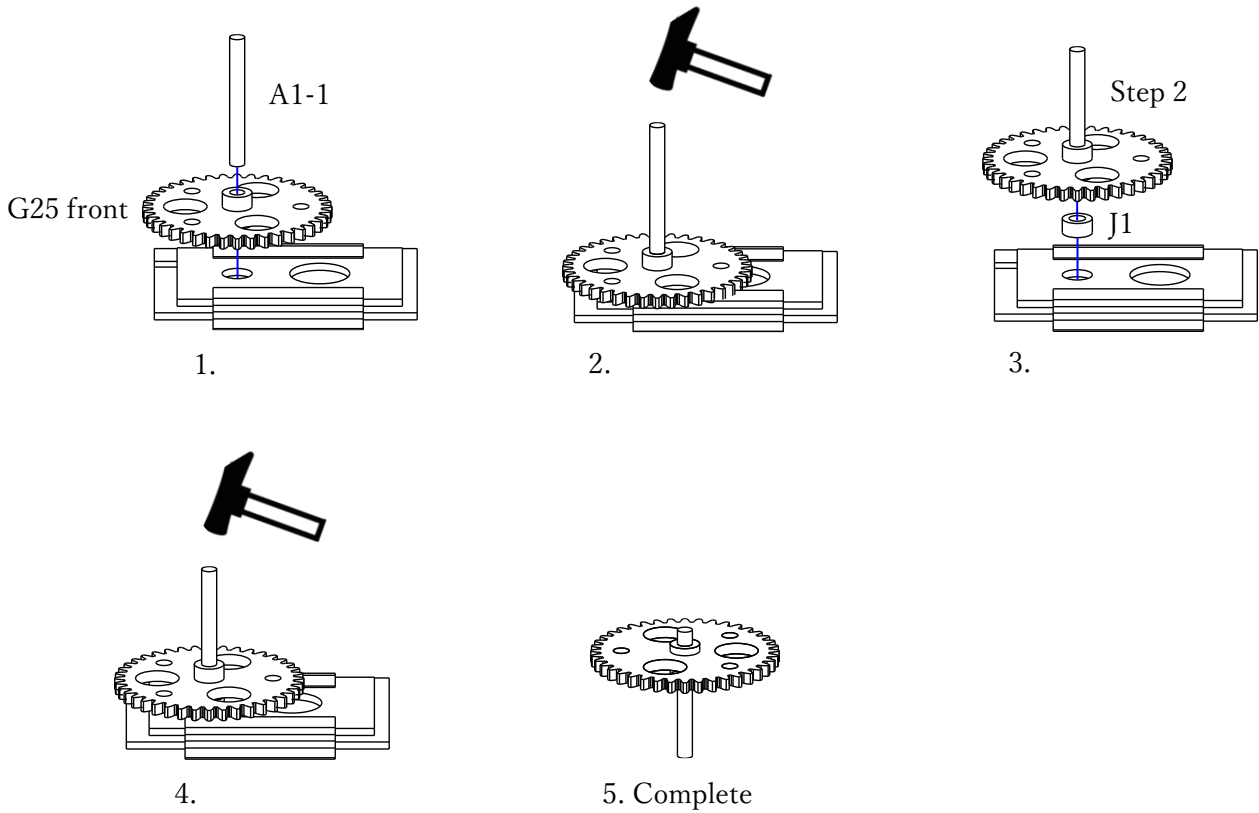

GA34 : Jupiter Drive Gear

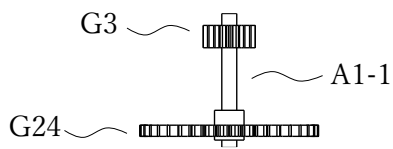

Completed View

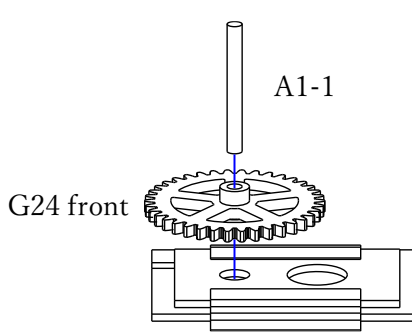

1.

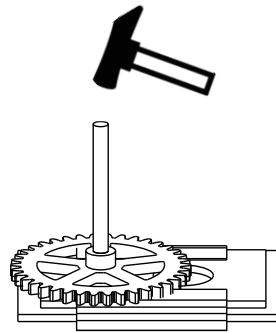

2.

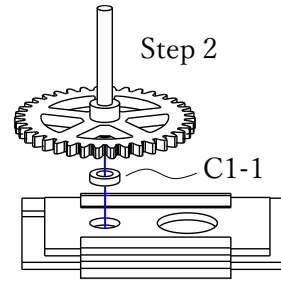

3. Use C1-1 temporarily as a jig. Return it to it after use.

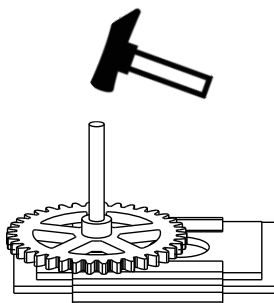

4.

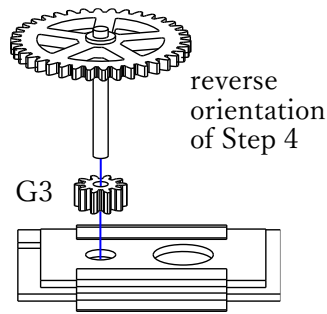

5.

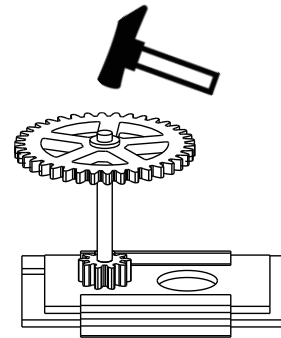

6.

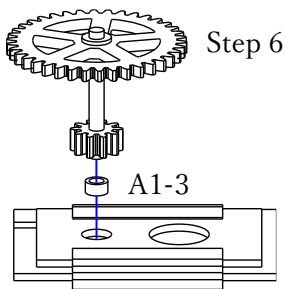

7. Use A1-3 temporarily as a jig. Return it after use.

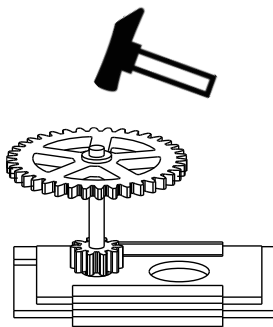

8.

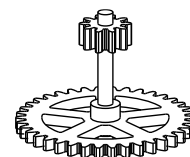

9. Complete

GA35 : Venus Gear

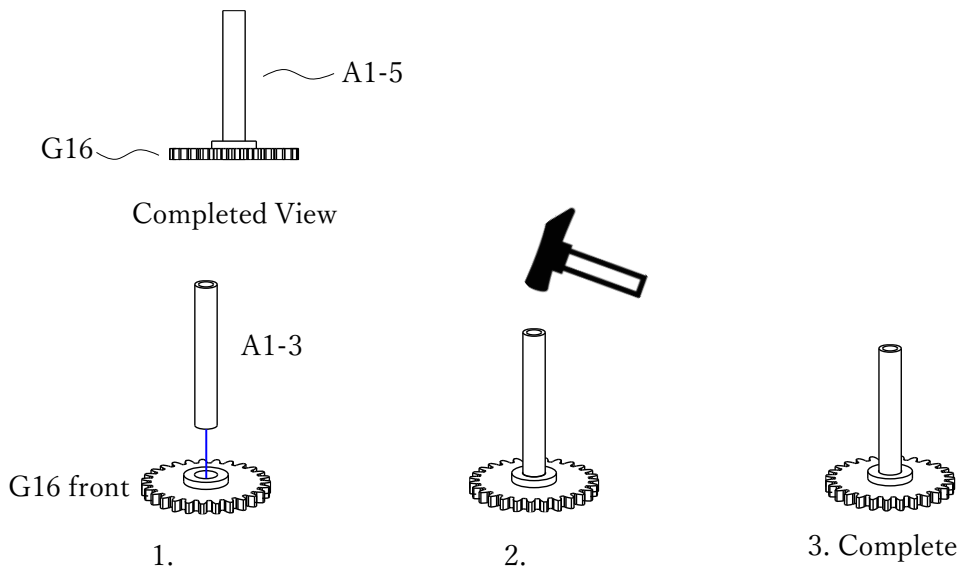

GA36 : Moon Drive System Gear 3

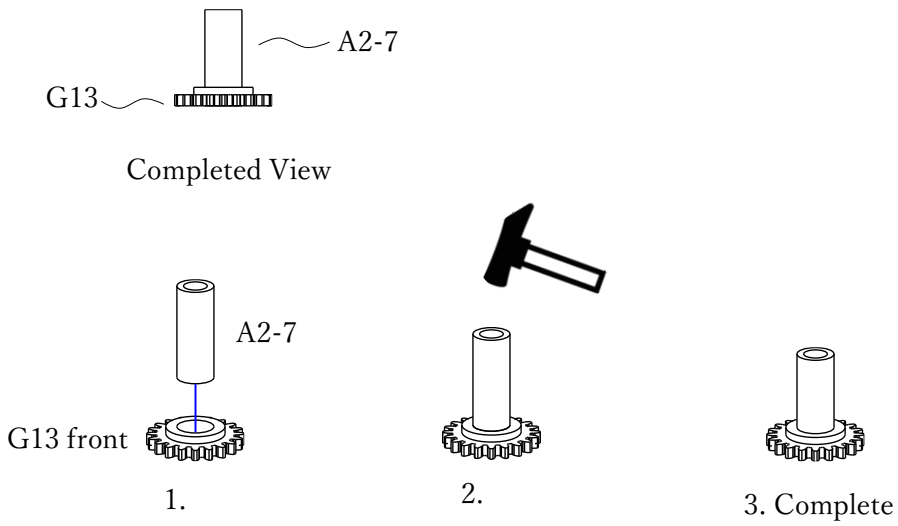

GA37 : Moon Drive Gear

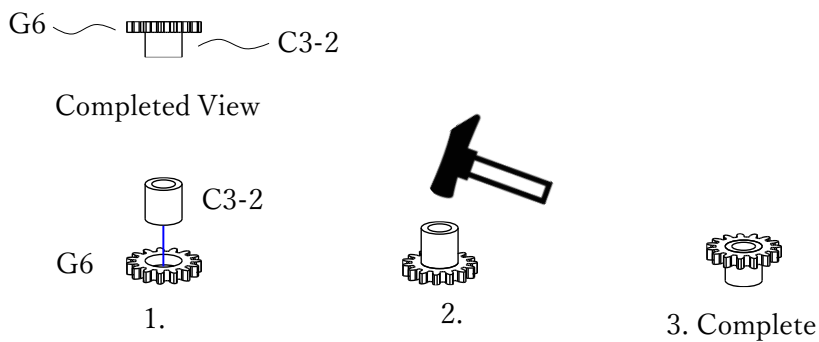

GA38 : Moon Gear

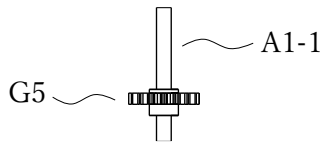

Completed View

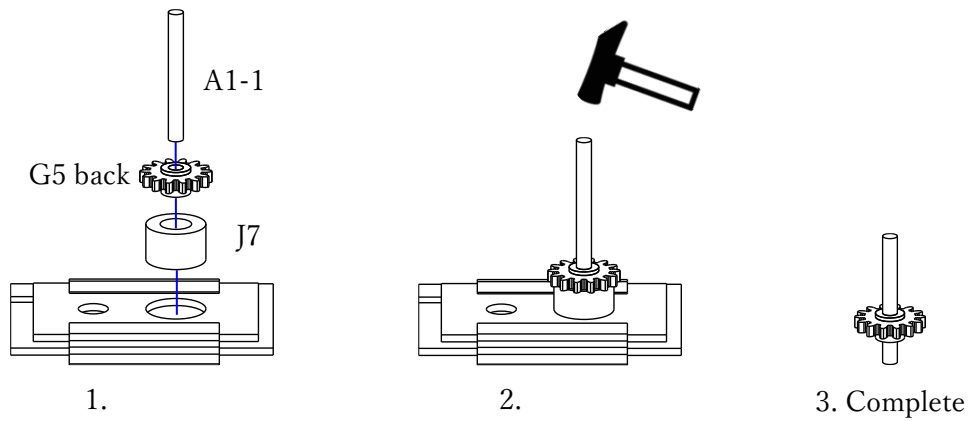

GA39 : Calendar Drive Gear

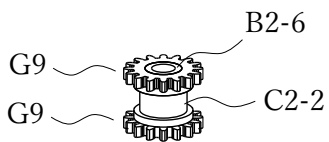

Completed View

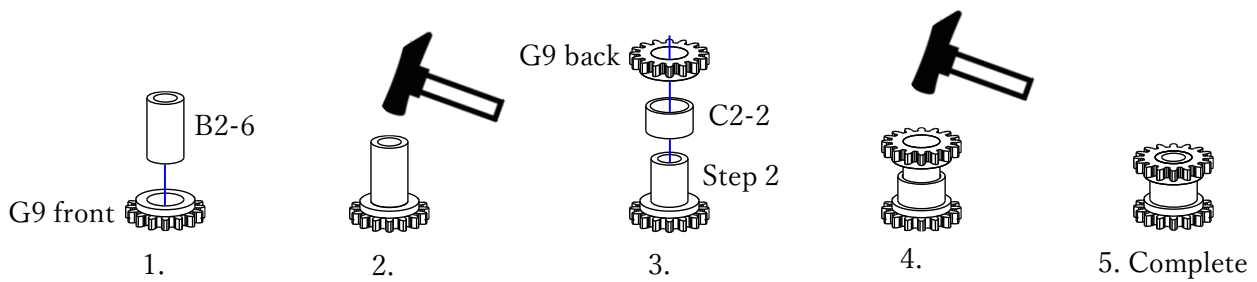

GA40 : Calendar Gear

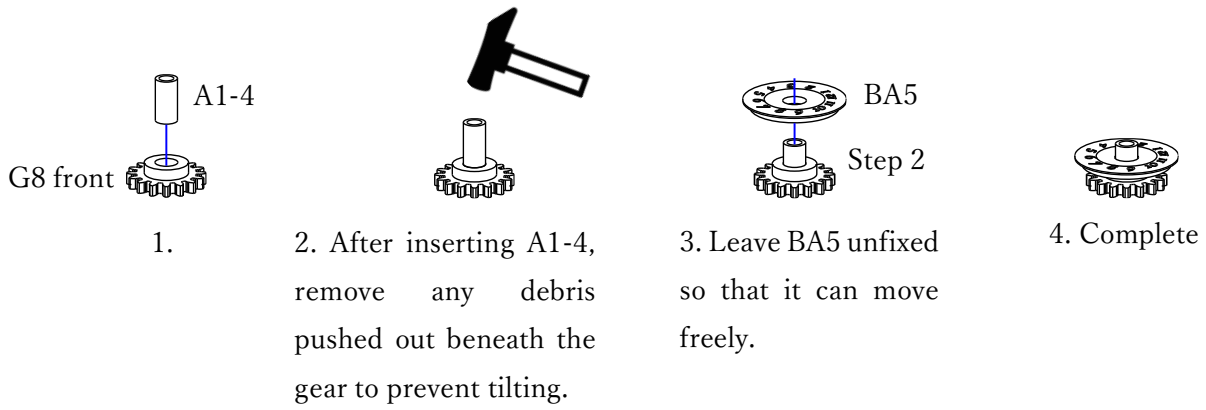
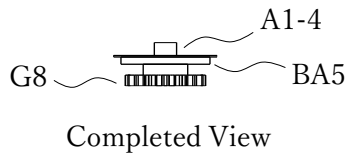

GA41 : Calendar Drive Components

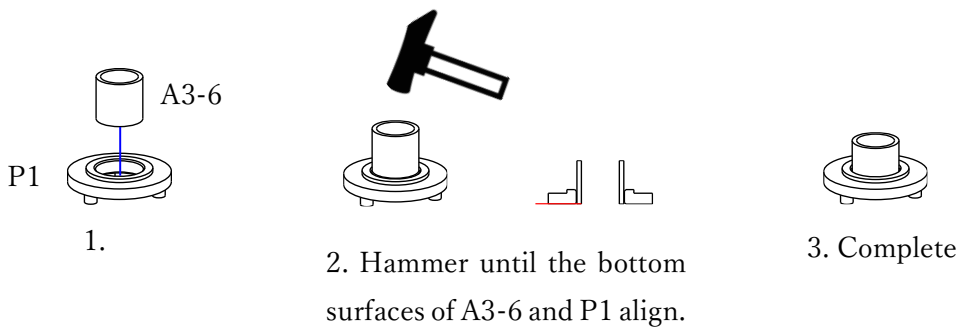
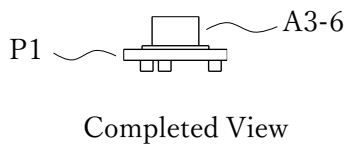

GA42 : Mars Gear

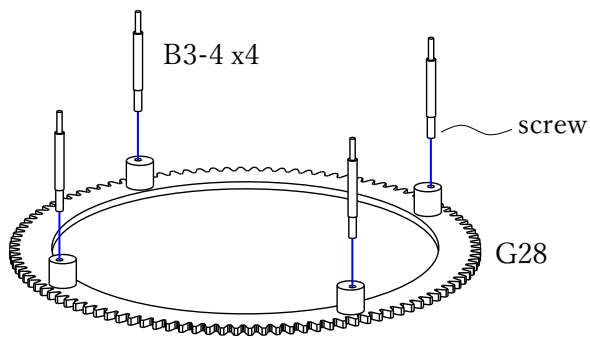

1. Screw B3-4 to G28 with the threaded side facing downward.

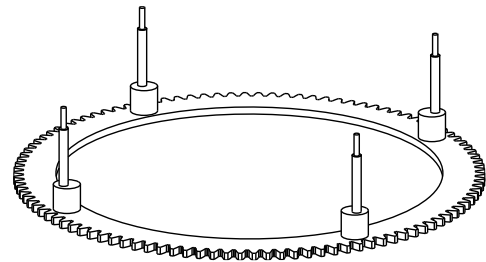

2. Complete

GA43 : Mars Cover

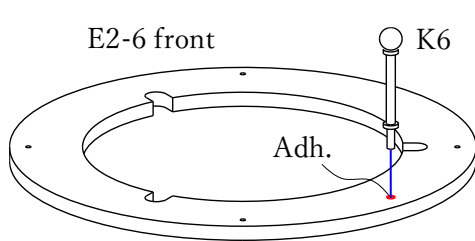

1. Since the shaft of K6 (Mars) passes through E2-6 from below, place E2-6 on a paper cup or similar support while bonding. K6 may tilt, so use C2-6 or another support to keep it place vertically until the adhesive cures. (Do the same for other planets hereafter.)

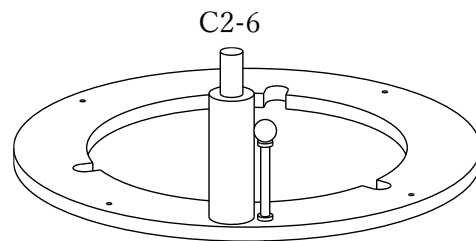

[Note] If the backing sheet of E2-6 has not been removed, please peel it off before use.

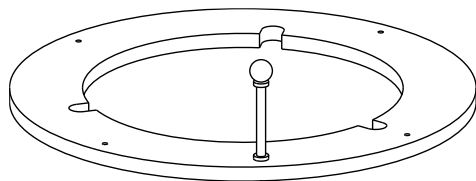

2. Complete

GA44 : Jupiter Gear

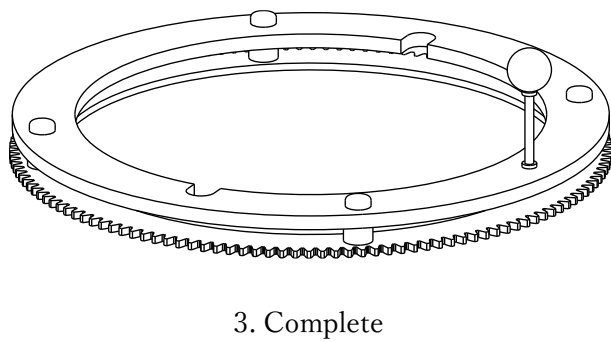
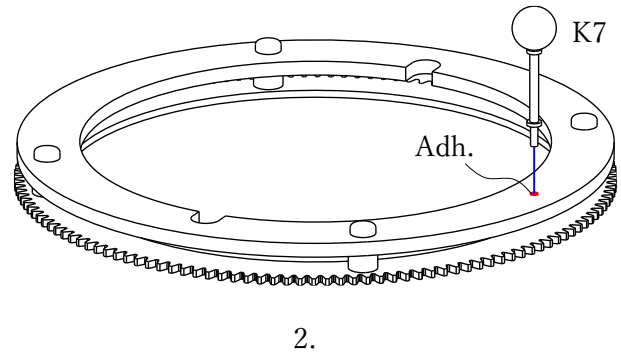
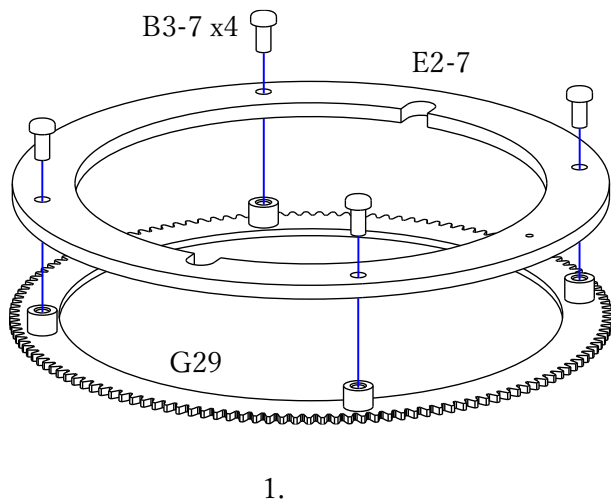

GA45 : Saturn Gear

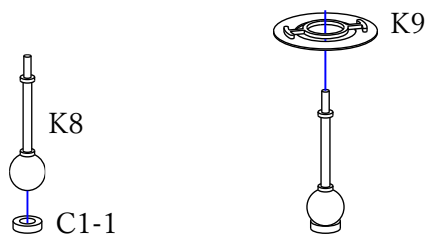

1. Place K8 vertically with C1-1 as a base.

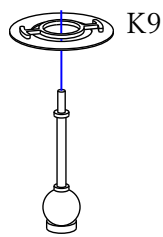

2.

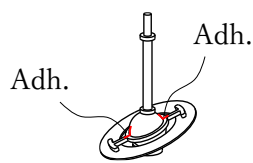

3. Bond K9 (Saturn's rings) at an angle. Touching one end of K9 to the surface creates a tilt of approximately 26° .

Be careful not to let the shaft fall during the process.

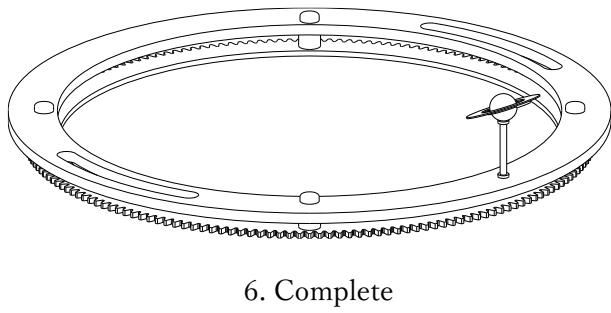
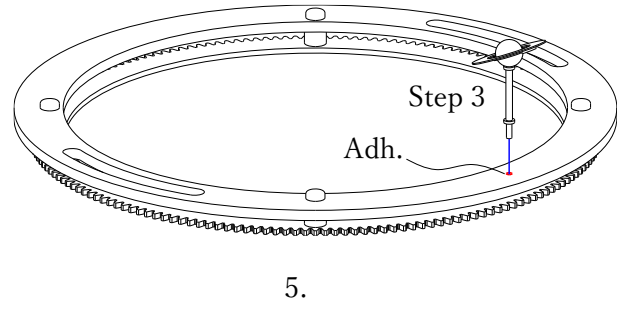
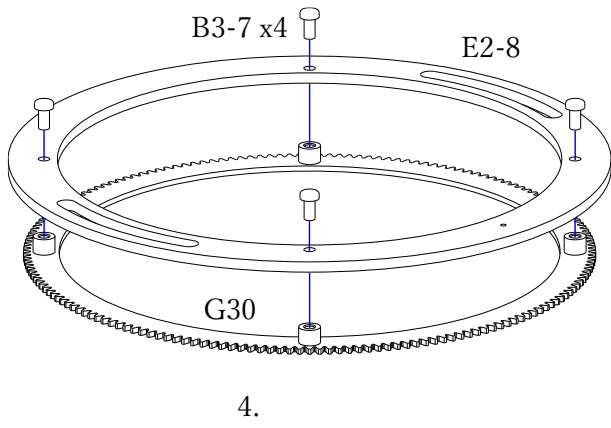

GA46 : Uranus Gear

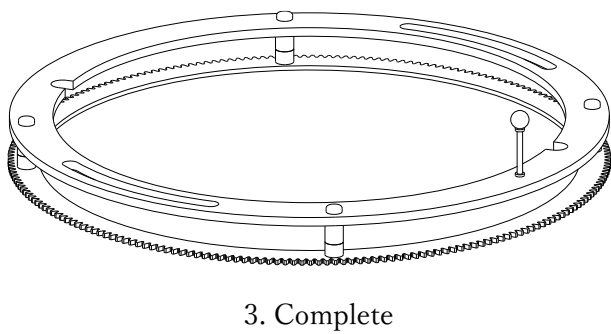
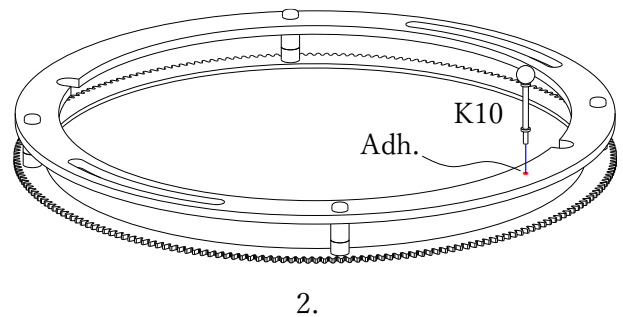
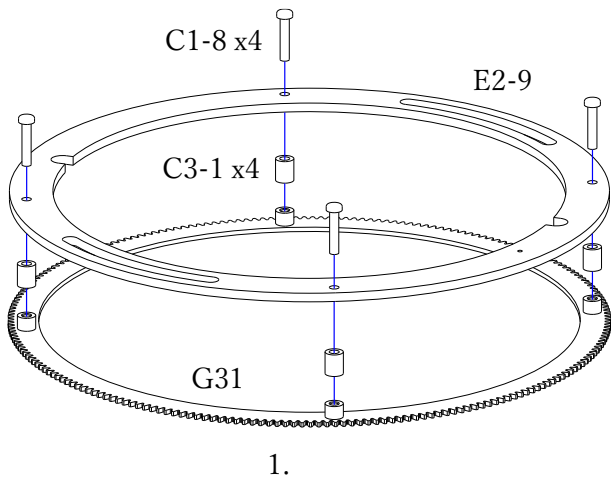

Bushing

Remove the backing sheets from all acrylic parts with D- and E-numbers before use.

Washing transparent acrylic parts with a neutral dish detergent will help prevent dust adhesion. (Do not allow multiple parts to contact each other underwater, as this may cause scratches.) If dust adheres, remove it with a paintbrush or similar tool.

CA1 : Calendar Mount

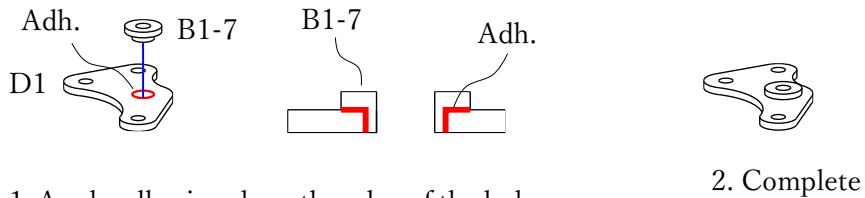

1. Apply adhesive along the edge of the hole in D1 and bond B1-7. Be careful not to get adhesive on the inner diameter of B1-7.

CA2 : Jupiter Gear Mount

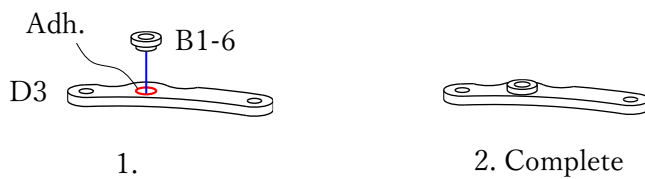

CA3 : Uranus Gear Mount 1

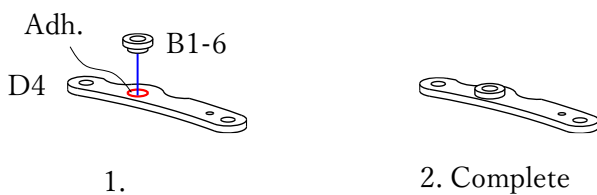

CA4 : Uranus Gear Mount 2

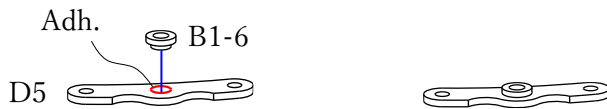

1. D5 has no front or back orientation.

2. Complete

CA5 : Comet Arm



1. D8 has no front or back orientation.

2. Complete

CA6 : Jupiter Mount

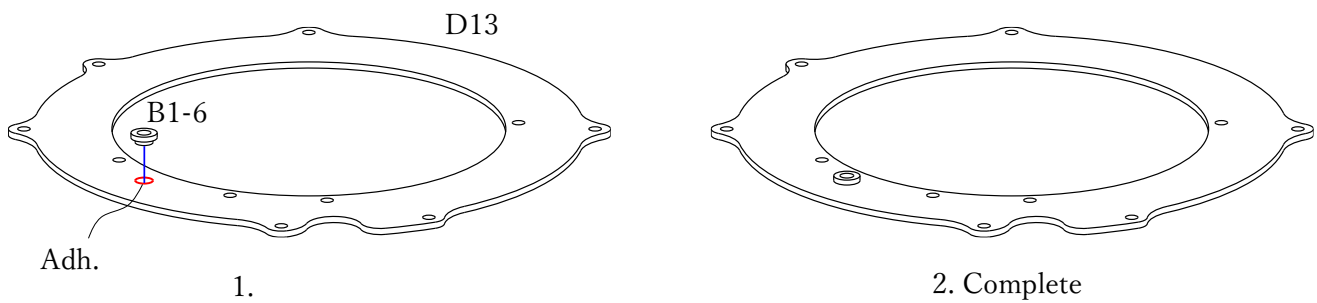

1.

2. Complete

CA7 : Time Scale Mount

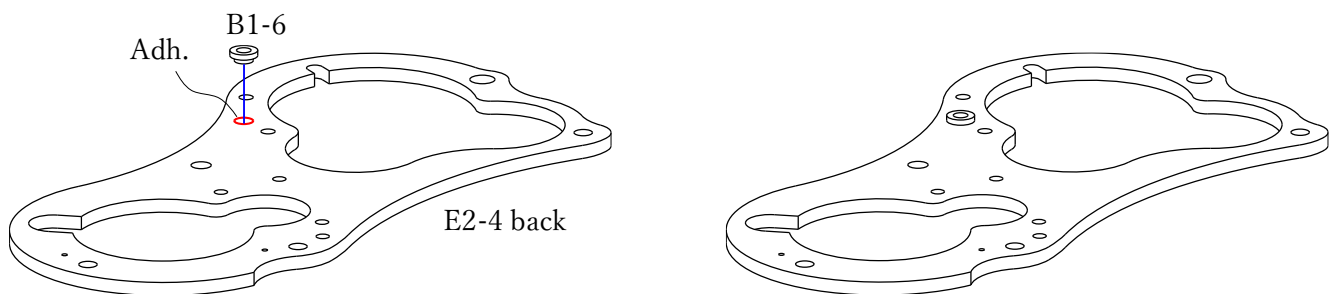

1. Bond B1-6 to the unpainted surface (back side).

2. Complete

CA8 : Mount 3

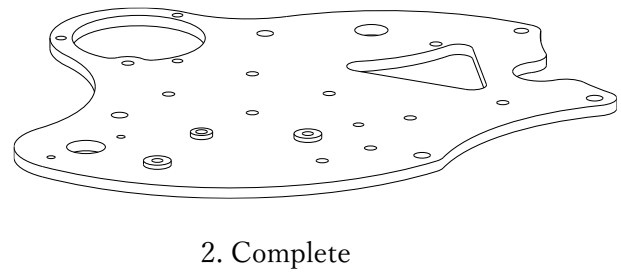
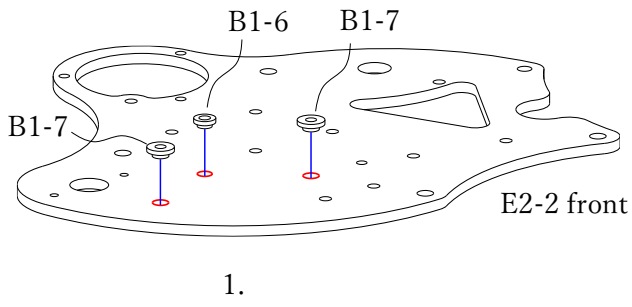

CA9 : Mount 2

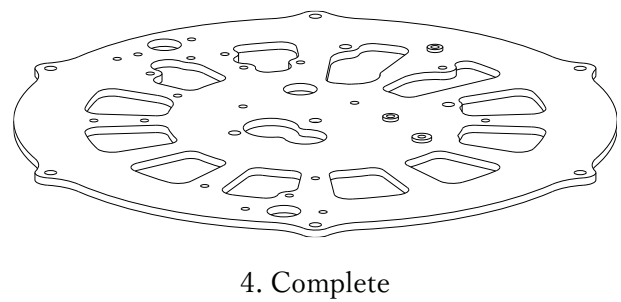
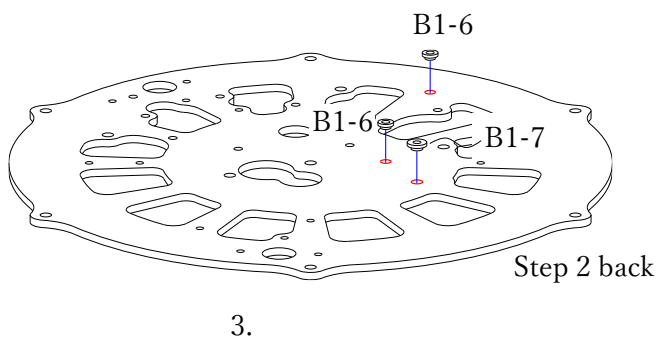
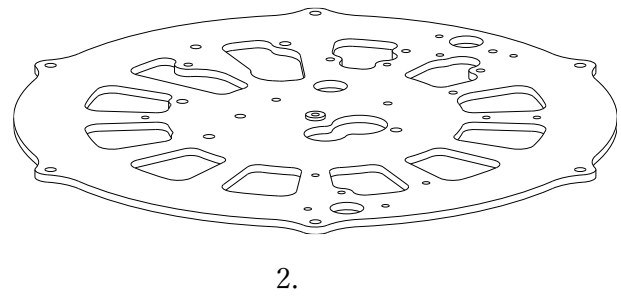
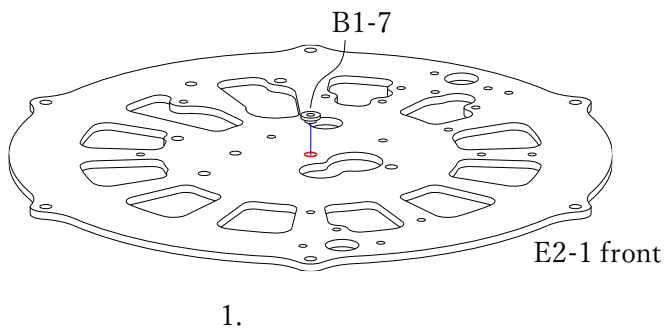

CA10 : Bottom Mount

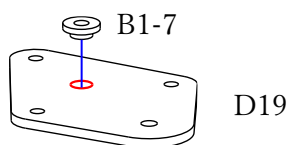

1. D19 has no front or back orientation.

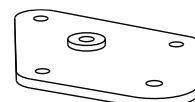

Module Assembly

MA1 : Mount 5

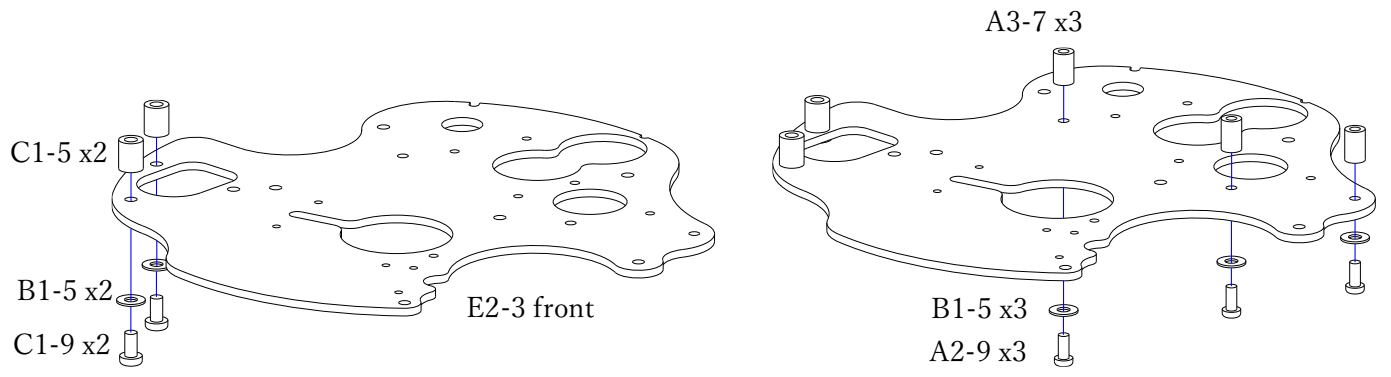

1. Screw C1-5 in place. After lightly assembling C1-5, B1-5, and C1-9 by hand, hold C1-5 and tighten C1-9 with a screwdriver.

2.

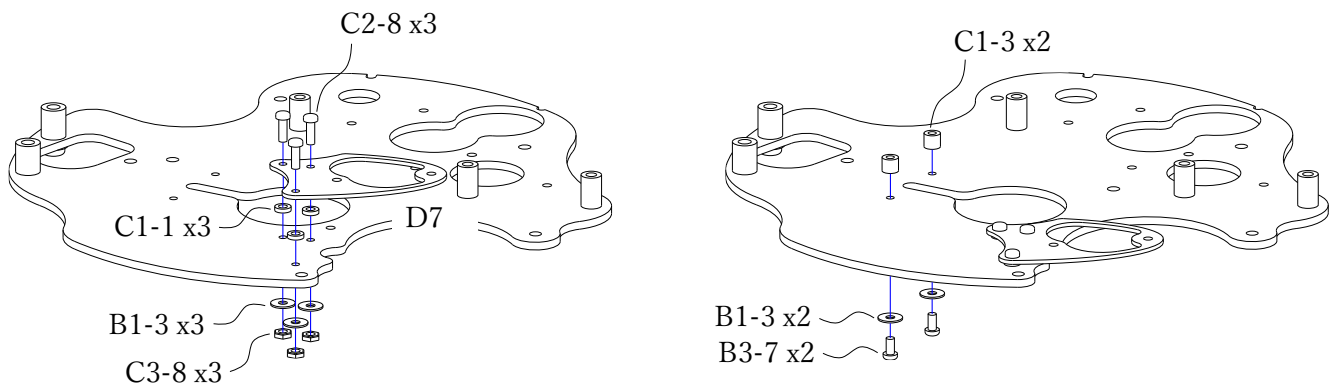

3. [Note] If the backing sheet of D7 has not been removed, please peel it off before use.

4.

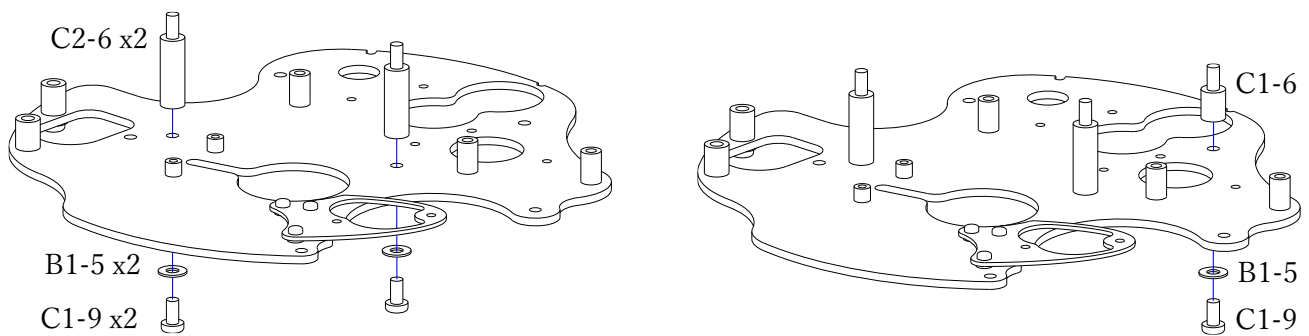

5.

6.

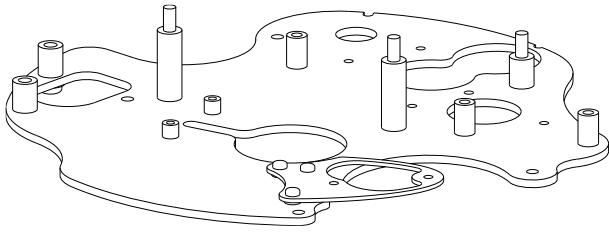

6. Complete

MA2 : Time Scale Mount

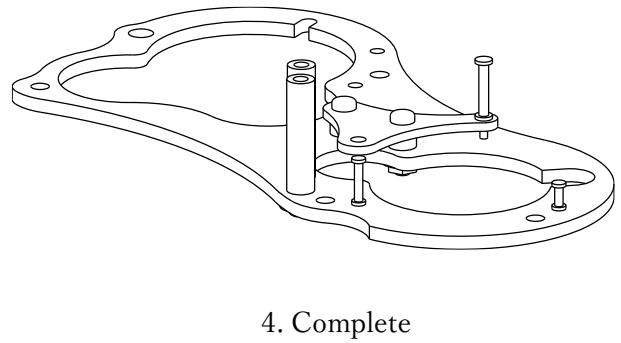
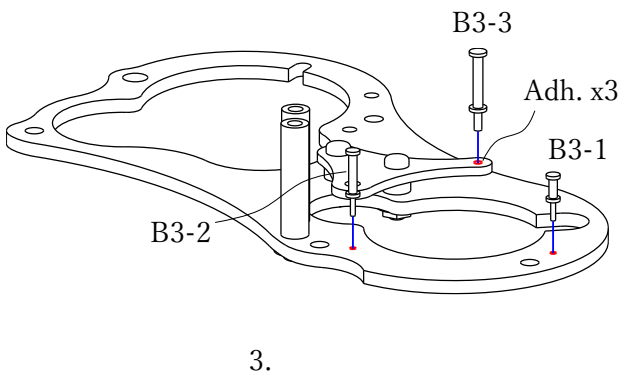
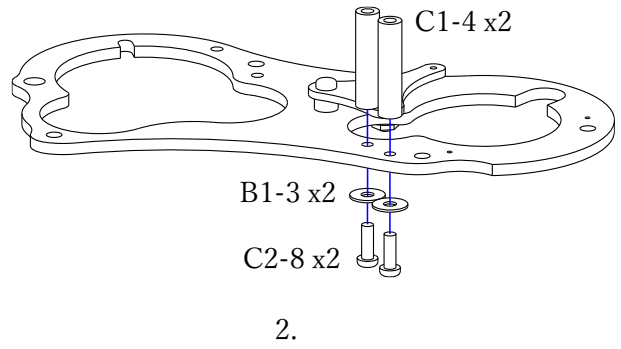
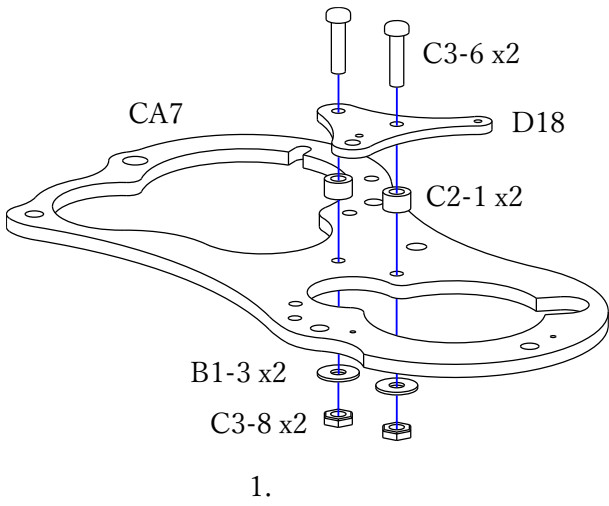

MA3 : Mount 3

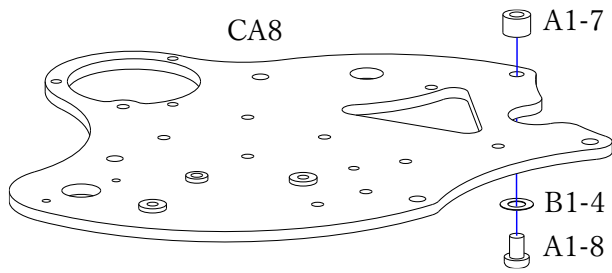

1.

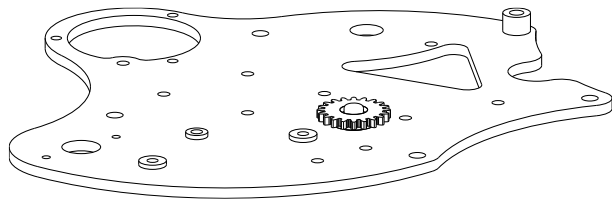

3. Complete

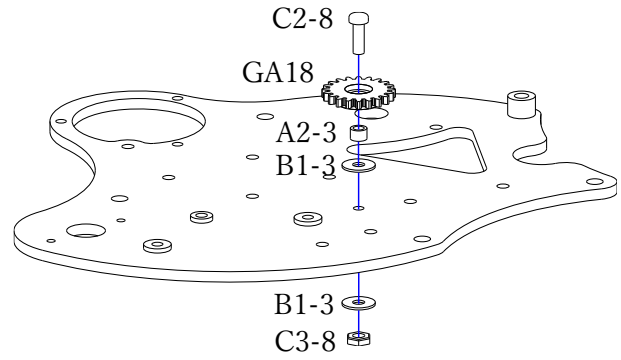

2. After installing GA18, rotate it by hand to ensure it moves smoothly.

MA4 : Mount 2

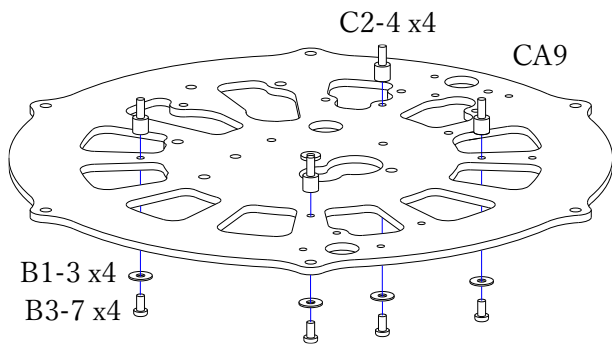

1.

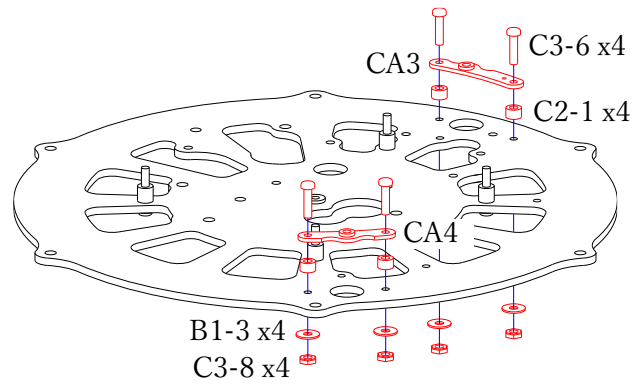

2.

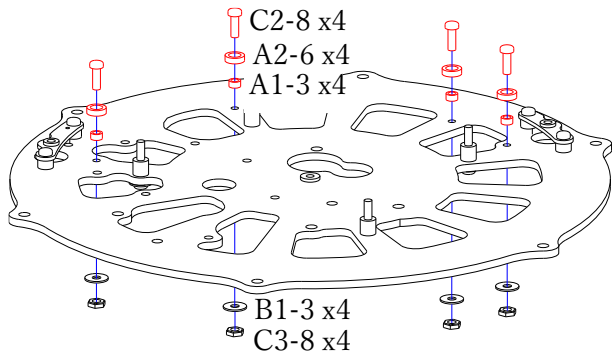

3.

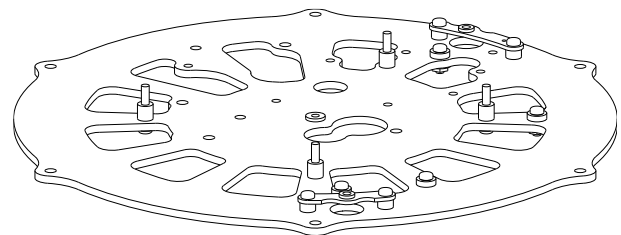

4. Complete

MA5 : Mount 1

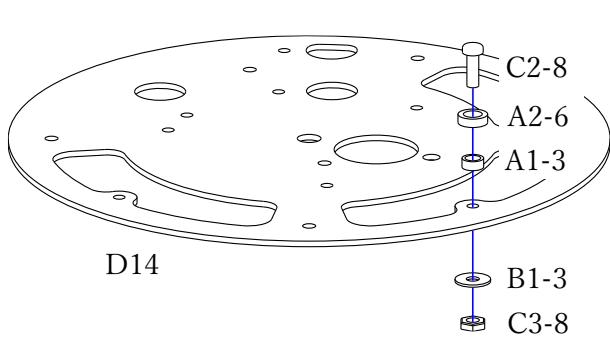

1. [Note] If the sheet of D14 has not been removed, please peel it off before use.

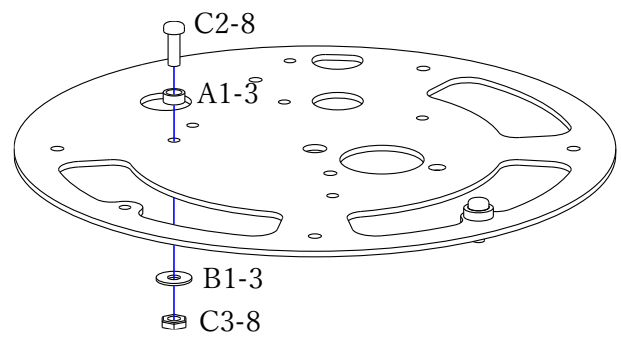

2.

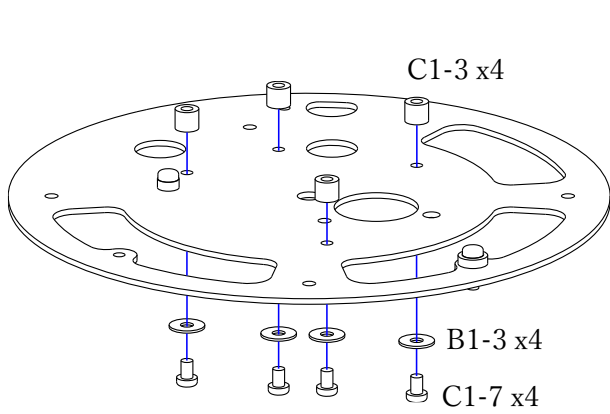

3.

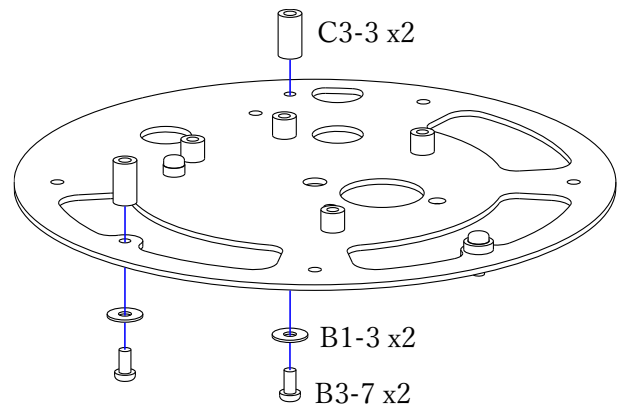

4.

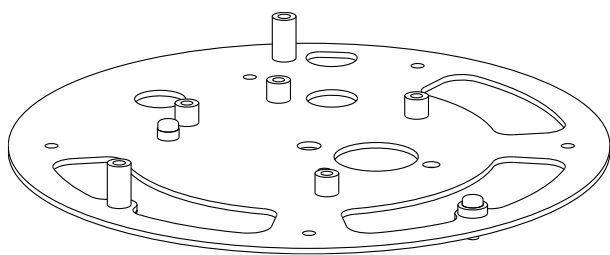

5. Complete

MA6 : Jupiter Mount

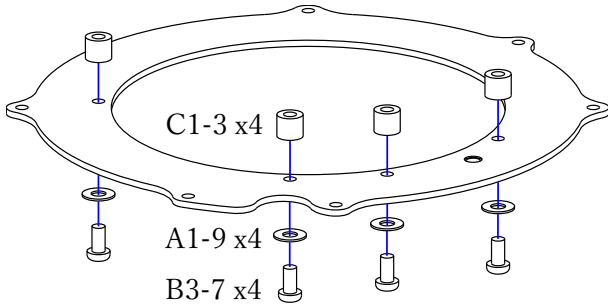

1.

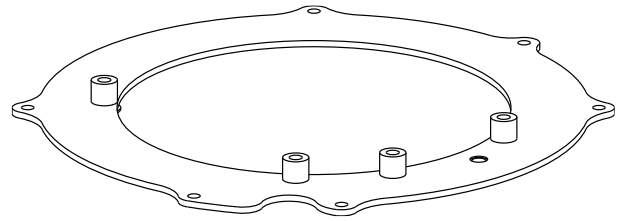

2. Complete

MA7 : Comet Slider

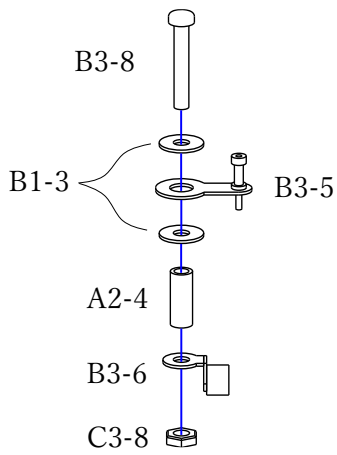

1.

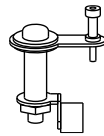

2.

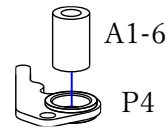

3.

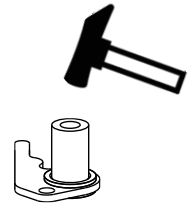

4.

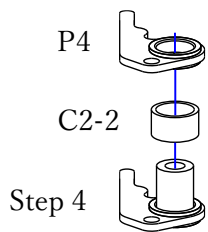

5.

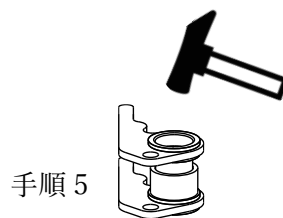

手順 5

6.

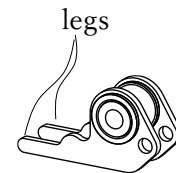

7. Adjust so that both legs touch the floor when placed.

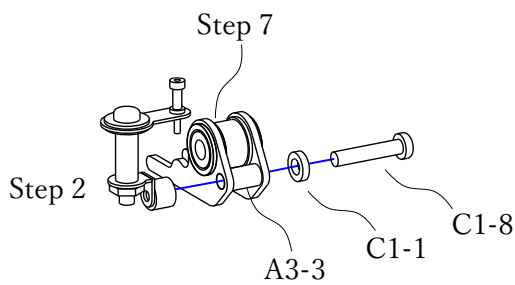

8.

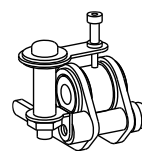

9.

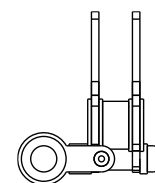

Top view

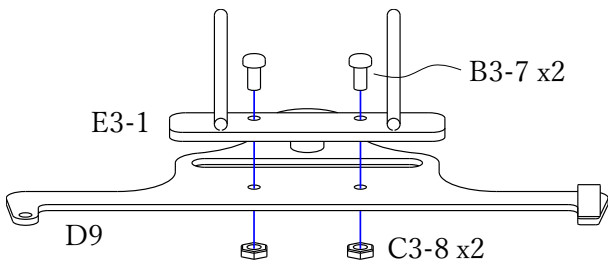

10.

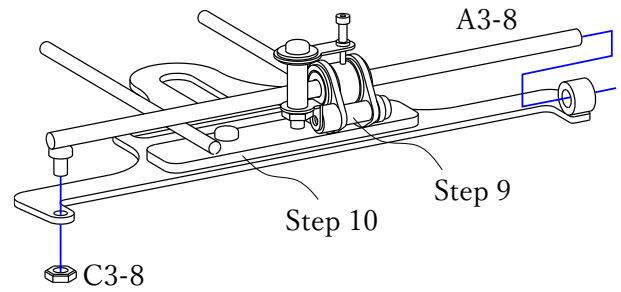

11. Pass Step 9 through A3-8 and attach it to Step 10. Ensure the legs of Step 9 are positioned under Step 10 as shown in Step 12. After lightly tightening C3-8 by hand, tilt the assembly and confirm that Step 9 moves from one end of A3-8 to the other under its own weight. If it does not move freely, review the assembly of the parts.

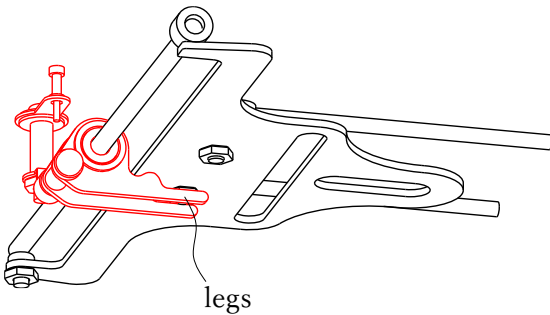

12.

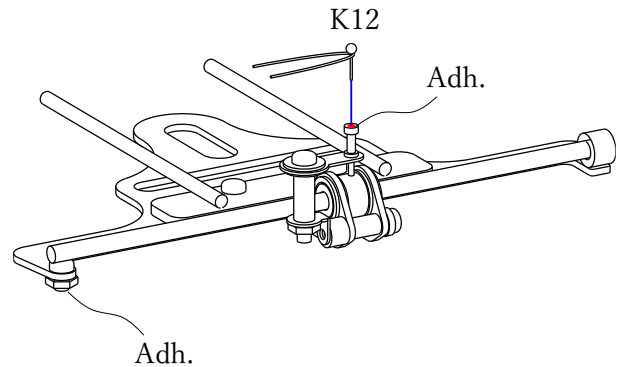

13. Lightly tighten C3-8 and bond between the screw and C3-8 to fix it. (Do not overtighten C3-8, as this may bend Step 10 and hinder Step 9's movement.)

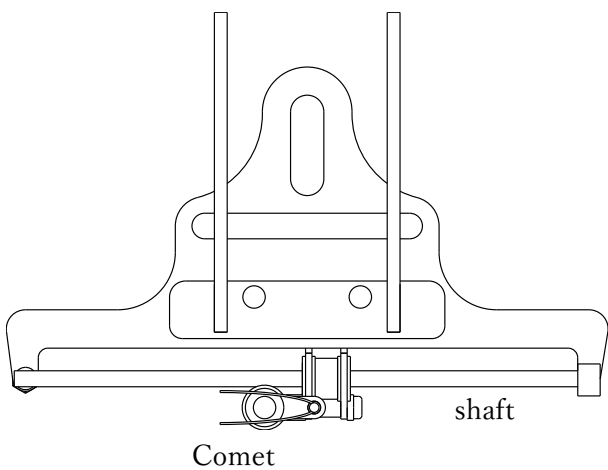

14. Adjust the comet (K12) so it is parallel to the shaft (A3-8).

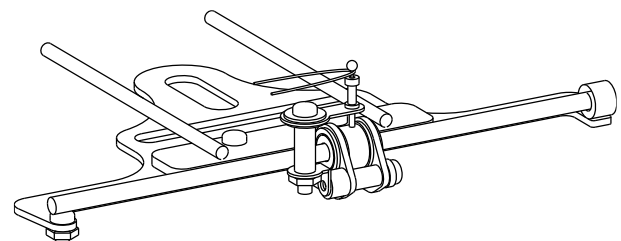

15. Complete

MA8 : Comet Arm

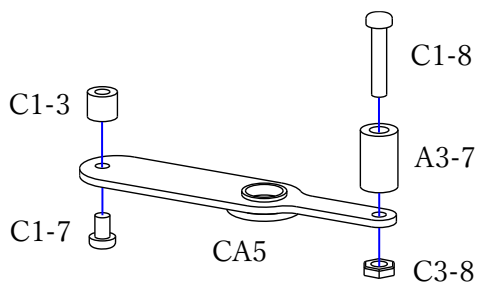

1. In the figure, screws for C1-8 and A3-7 will not engage; this is normal. Please assemble them as is.

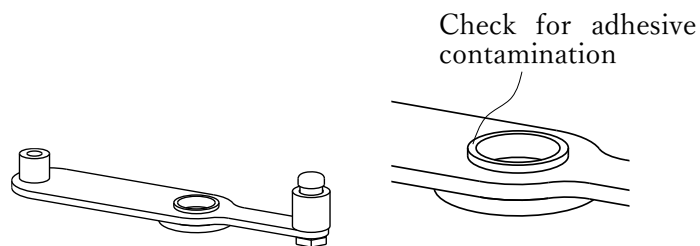

2. Check for adhesive contamination: Inspect the top edge of the illustrated part (upper edge of B1-8) and remove any adhesive with tweezers if present. (Adhesive in this area may contact B1-3 in Step 4 and cause obstruction in Step 5.)

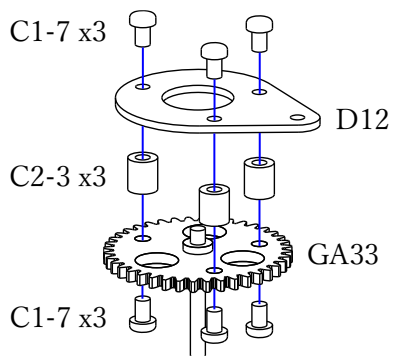

3.

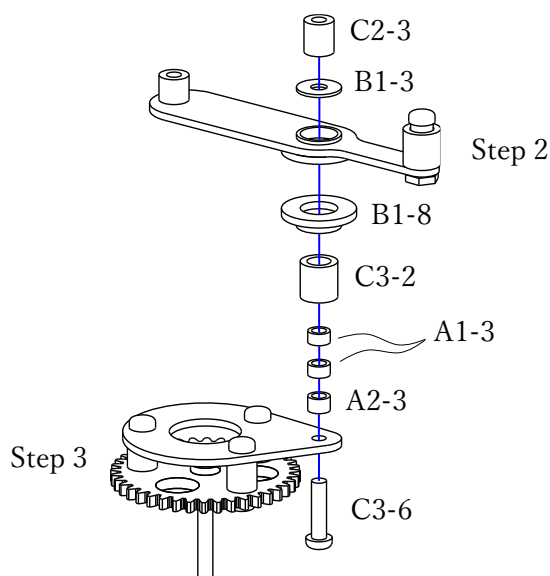

4.

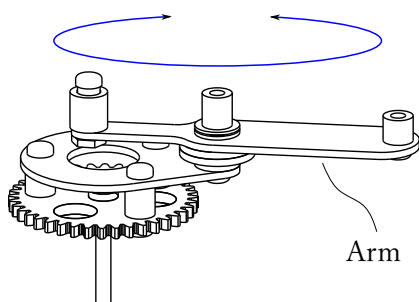

5. Ensure the arm rotates freely. If there is resistance, review Step 2 or gradually tighten C2-3 while rotating Step 2 of Step 4 to remove the obstruction.

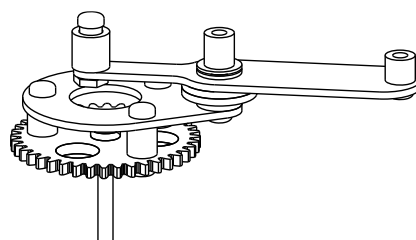

6. Complete

MA9 : Earth Gear Assy

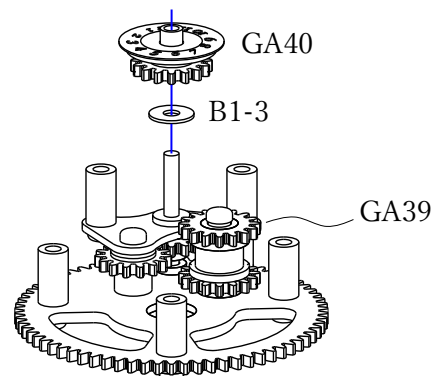
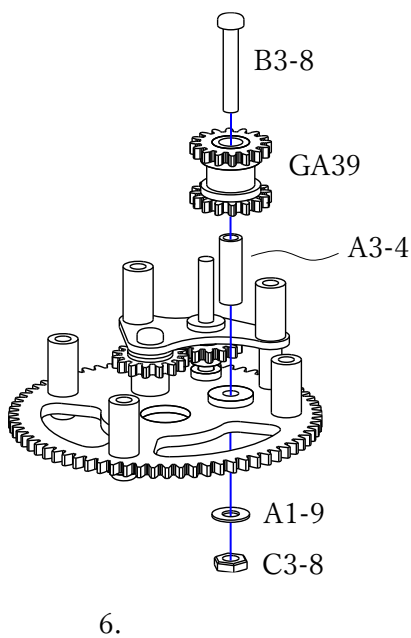
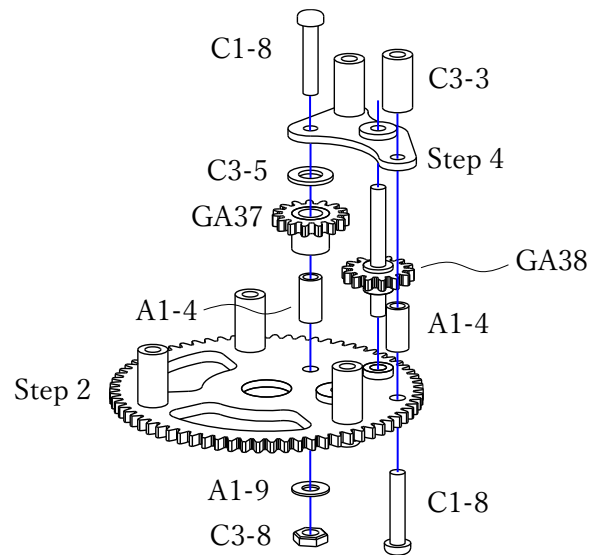
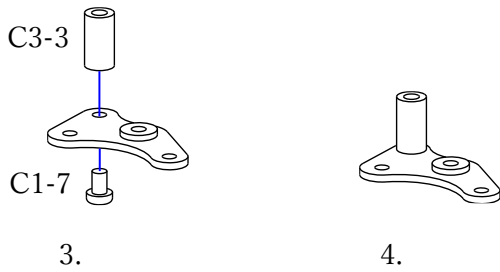
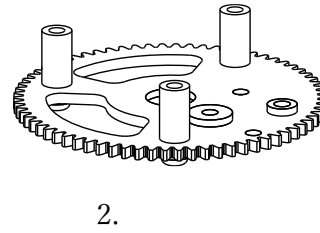
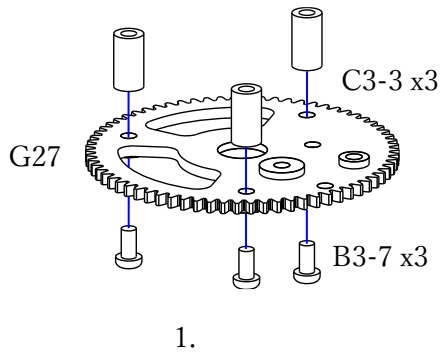

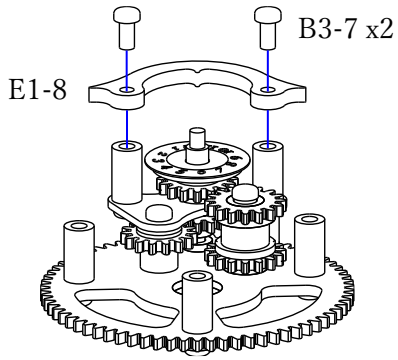

8.

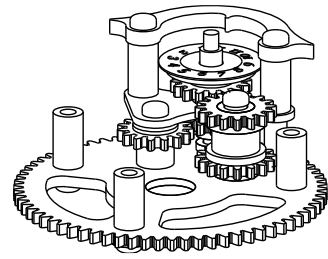

9. Complete

MA10 : Mount 6

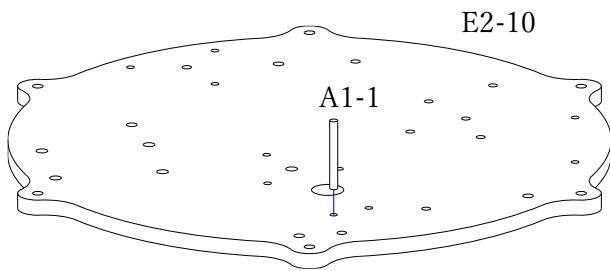

1.

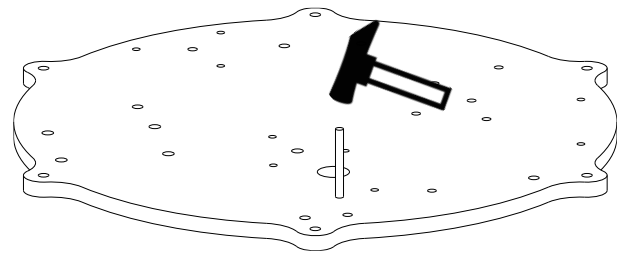

2. Hammer A1-1 until through the back side. Be careful to hammer it in the correct location.

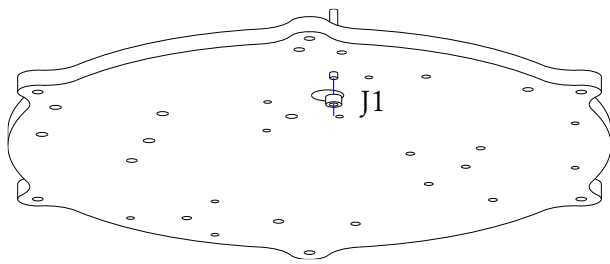

3.

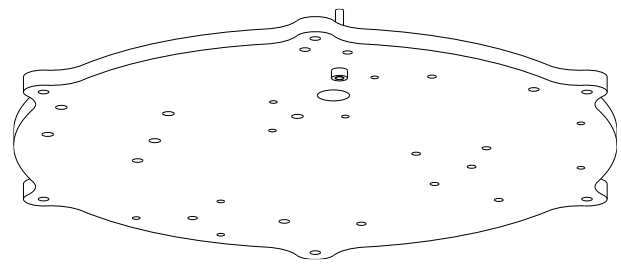

4. Align the insertion length of A1-1 with J1.

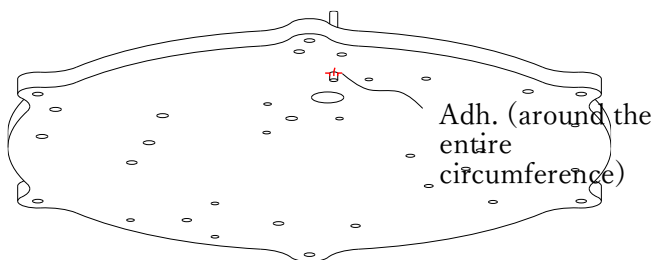

5. Adjust A1-1 to stand vertically and apply adhesive to the penetrated side. Do not apply adhesive to the front side.

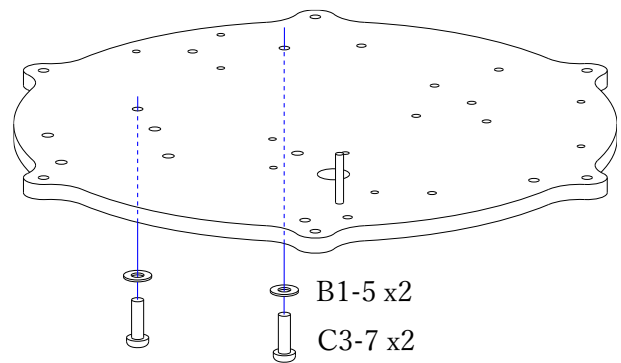

6. Assemble screws. Pay attention to the assembly location.

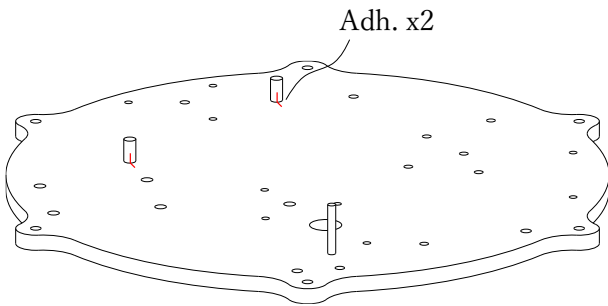

7. Apply adhesive to the base of the screws.
 (Reinforce the bottom plate E2-10 with adhesive, as vibration may loosen the screws.)

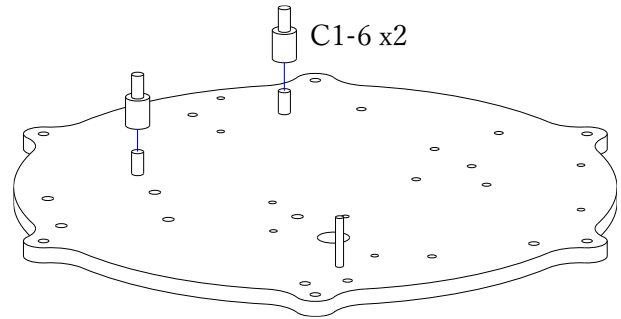

8. Screw C1-6 in place. Do not overtighten, as the bottom plate may deform.

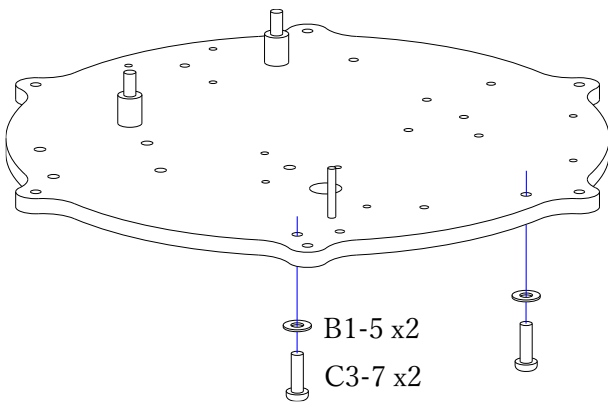

9.

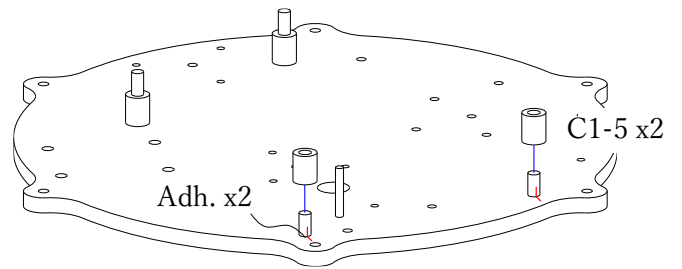

10.

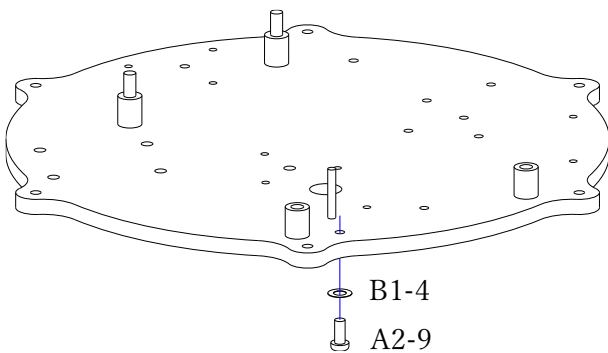

11.

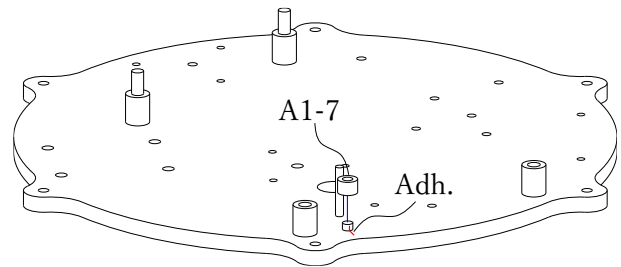

12. Ensure adhesive does not get on the top of screws (A2-9 in Step 11).
 (A1-7 and A2-9 support gear shafts (Bearing), and adhesive on these areas may interfere with gear rotation.)

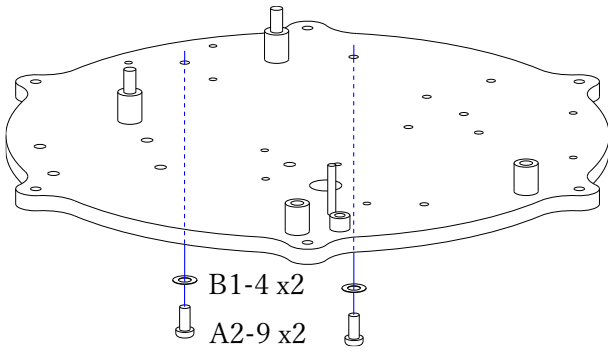

13.

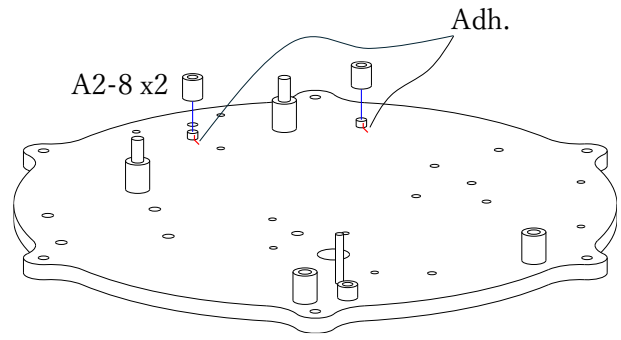

14. As in Step 12, be careful not to allow adhesive to touch the top of the screws (A2-9 in Step 13).

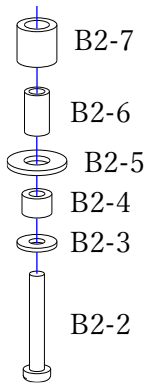

15. Make six identical units. These will serve as the legs of the product.

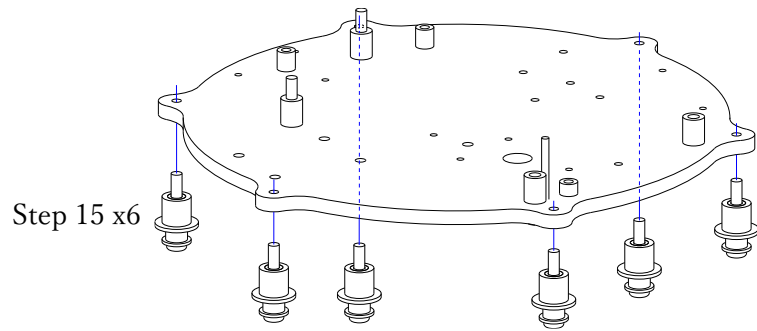

16.

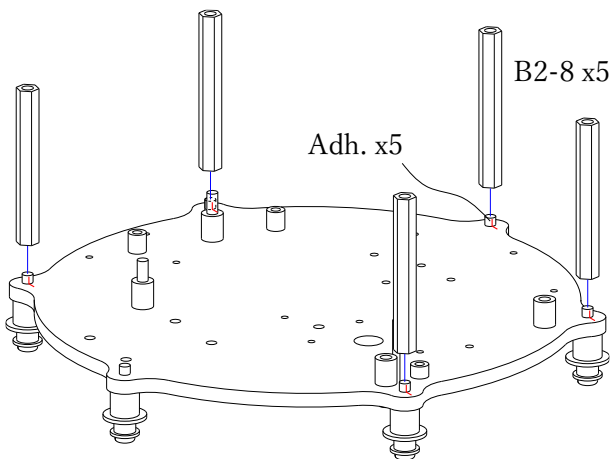

17. Apply adhesive to the base of five screws and screw in B2-8.

Note that one B2-8 is left uninstalled for a later step.

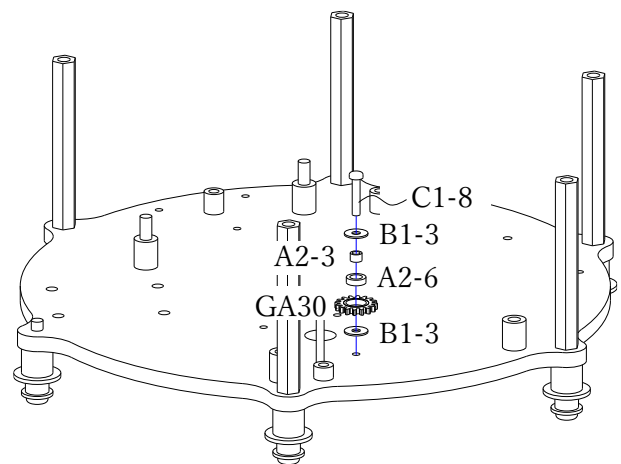

18.

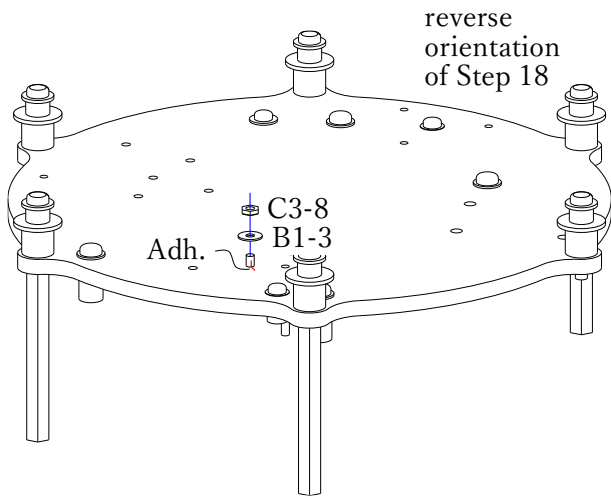

19.

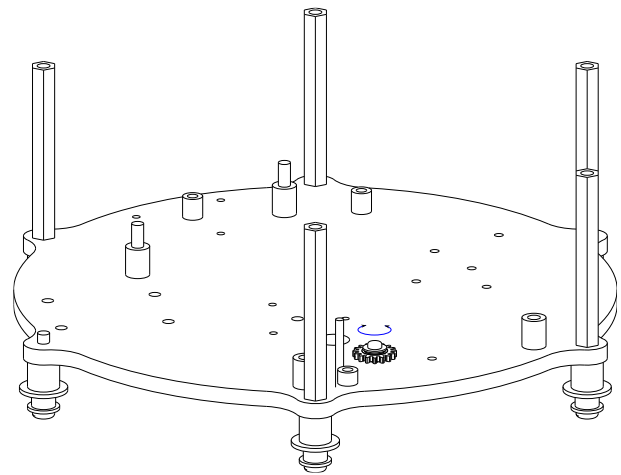

20. Confirm that GA30 rotates freely without obstruction.

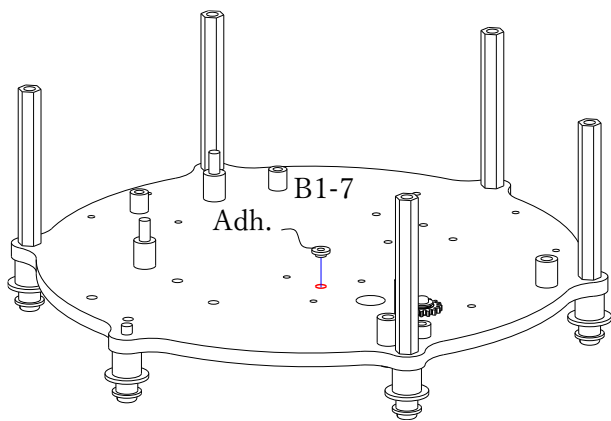

21. Please perform Steps 21–26 consecutively before the adhesive cures.

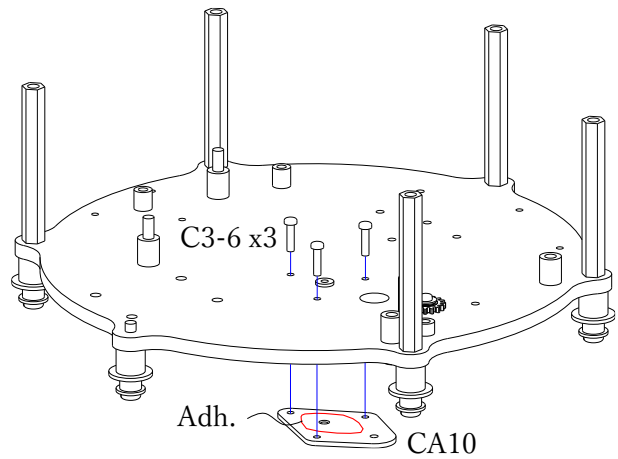

22. Apply adhesive to the upper side of CA10 with the bushing bonding surface facing downward, then attach it.

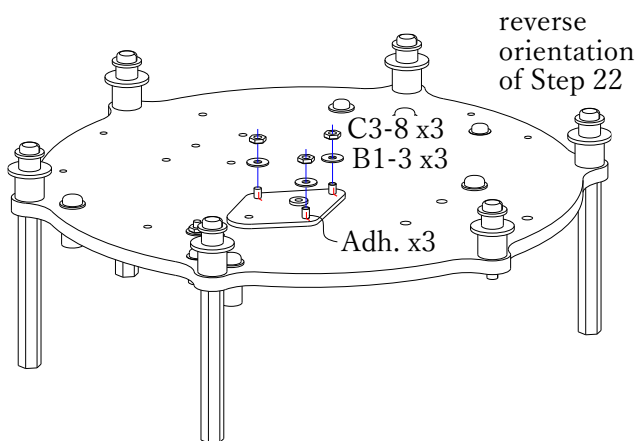

23. Lightly fasten with a screw.

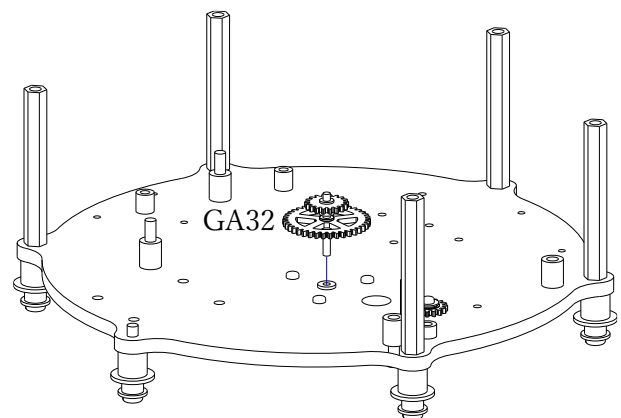

24. Insert GA32 through the bushing.

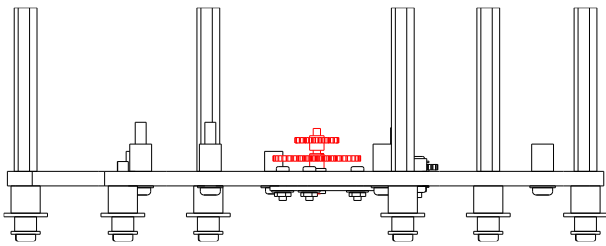

25. Check from the side to ensure that GA32 is not tilted. If it is tilted, fine-tune the positions of B1-7 and CA10 installed in Steps 22 and 23 so that it becomes horizontal.

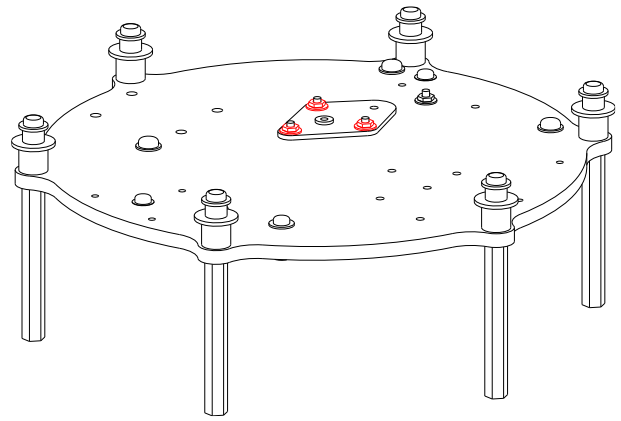

26. Remove GA32, then tighten C3-8 from Step 23. (Be careful not to overtighten, as this may cause the plywood to dent.)

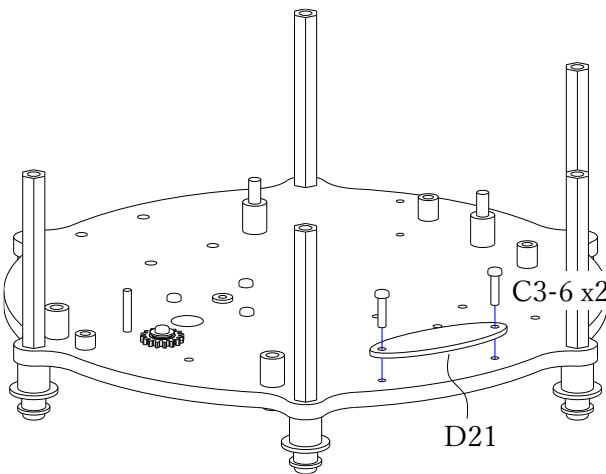

27. Screw D21 (Name Plate) in place. rear side

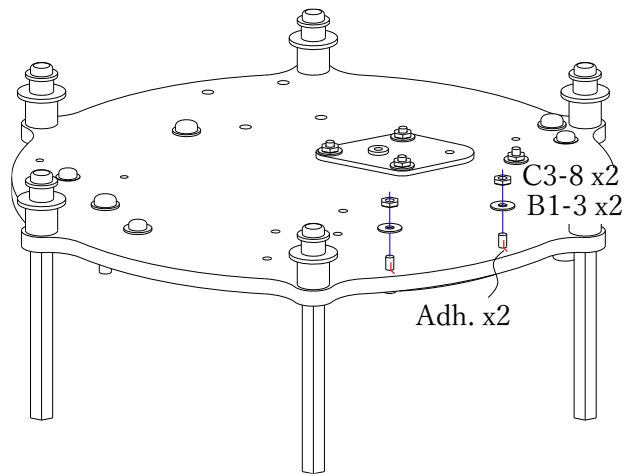

28.



front side

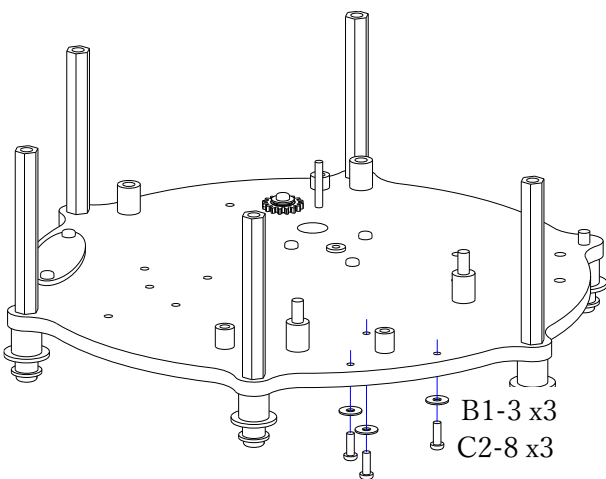

29.

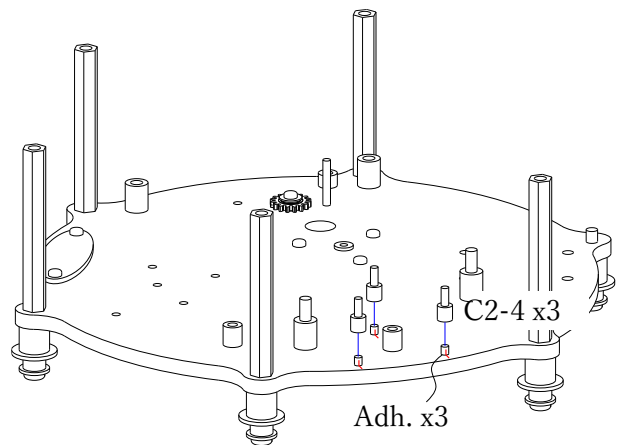

30.

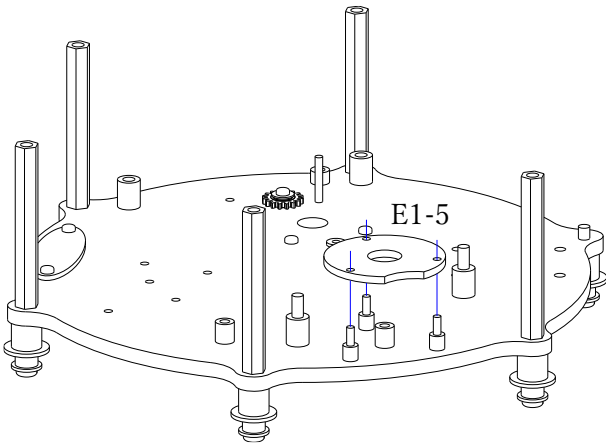

31. Install E1-5 with the painted surface facing upward.

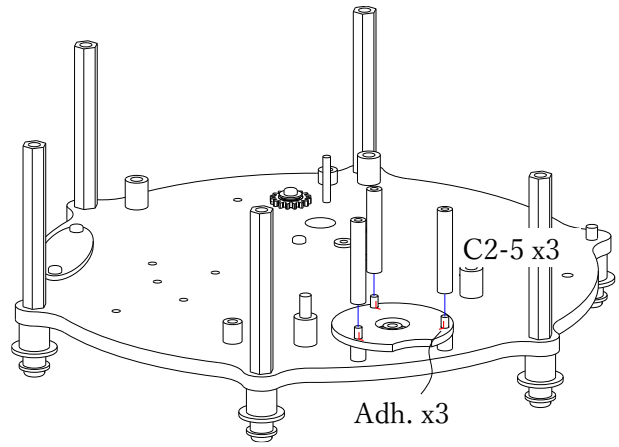

32.

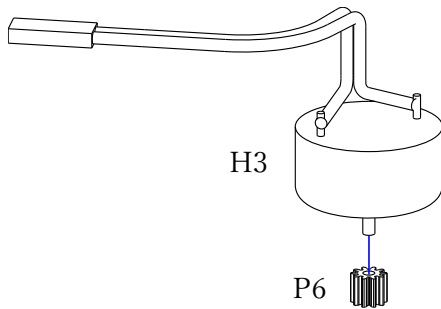

33. Press P6 (pinion gear) onto the motor shaft (H3).

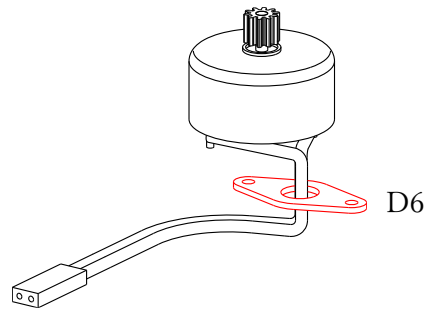

34. Pass D6 over the motor cable. (D6 has no orientation.)

[Note] If the sheet on D6 has not been removed, peel it off before use.

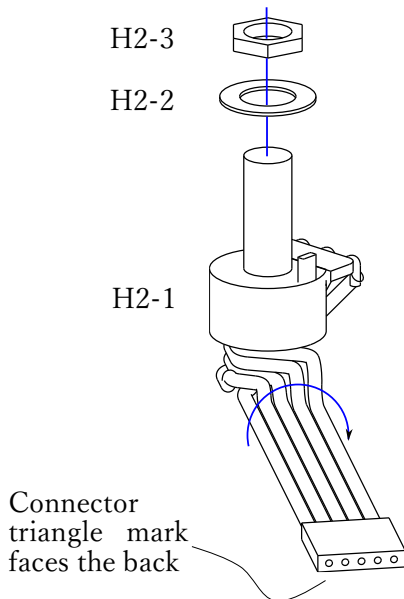

35. Remove H2-2 and H2-3 from H2-1 (variable resistor). Twist the cable clockwise so that the triangle mark on the connector faces the back side.

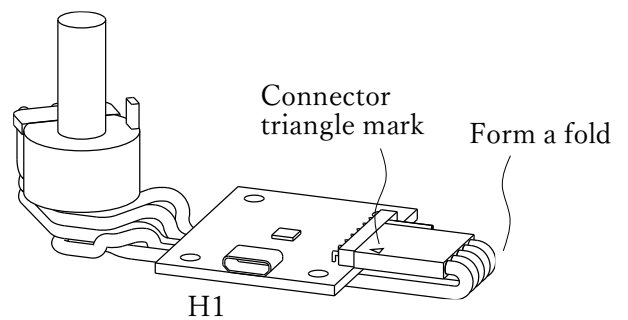

36. Fold the cable so that the triangle mark on the connector faces the front as shown in the diagram, and insert it into the pins of H1 (motor controller) (see Steps 38, 39).

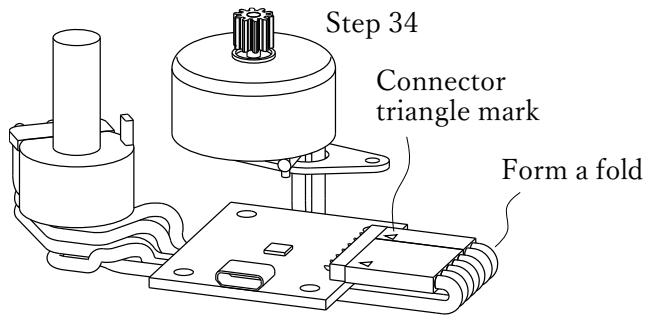

37. As in Step 36, fold the motor cable so that the triangle mark faces the front and insert it into H1 pins (see Steps 38, 39).

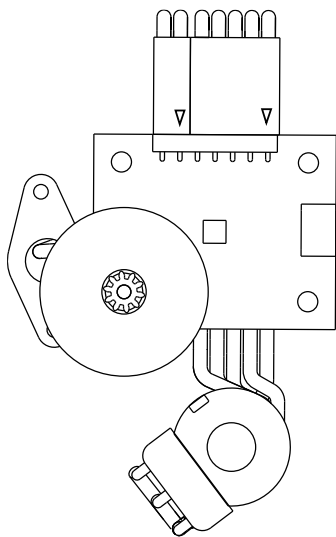

38. Top view

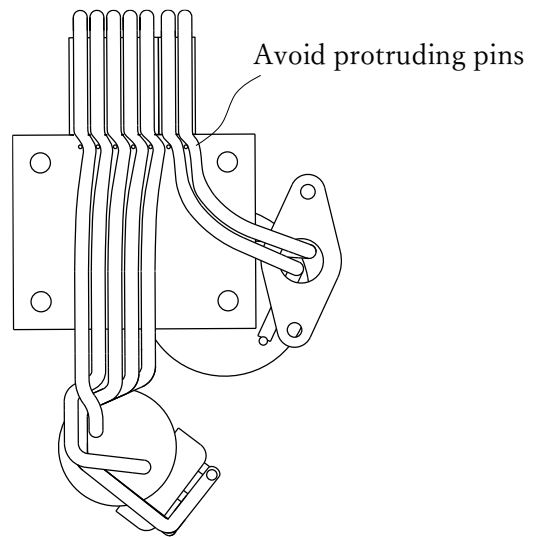

39. Bottom view

Route each cable to avoid protruding pins. Take care to prevent cables from crossing or being pierced by pins. Also, ensure that the variable resistor and motor cables exit from different sides of the motor controller.

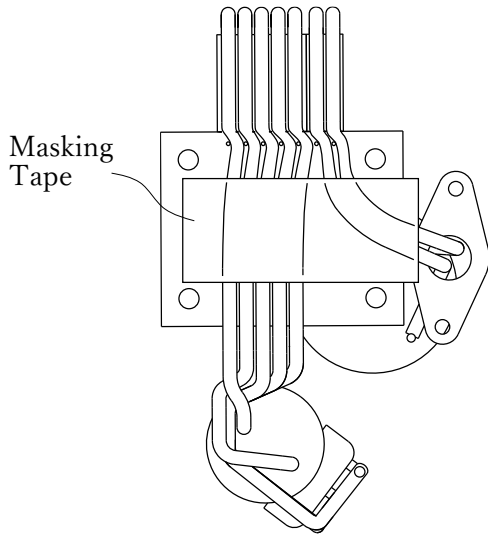

40. Fix the wiring with masking tape without disturbing Step 39. Pay special attention to the motor-side cable and hold it with masking tape by hand until Step 42.

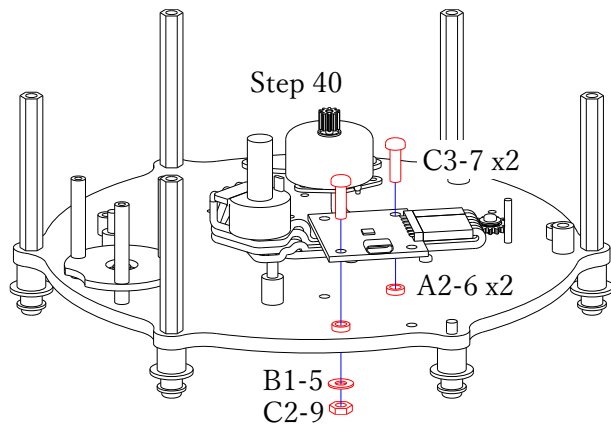

41. Place the assembly on A2-6 while maintaining Step 40, pass the screw (C3-7), and lightly tighten the front nut (B1-5 and C2-9). Carefully press the motor controller from above to ensure no gaps with A2-6. If gaps remain, return to Step 39 and adjust the wiring.

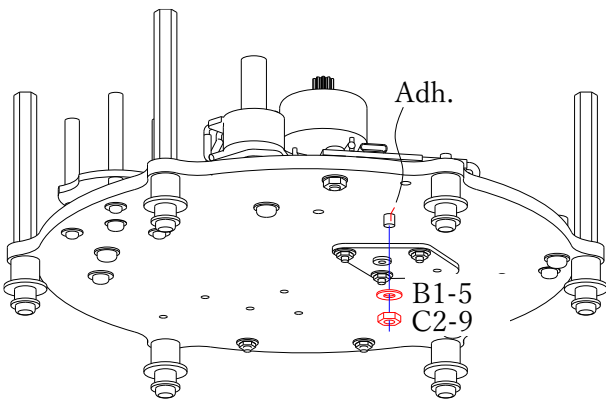

42. Apply adhesive to the rear screw (C3-7) and lightly tighten B1-5 and C2-9 to prevent the cable from lifting.

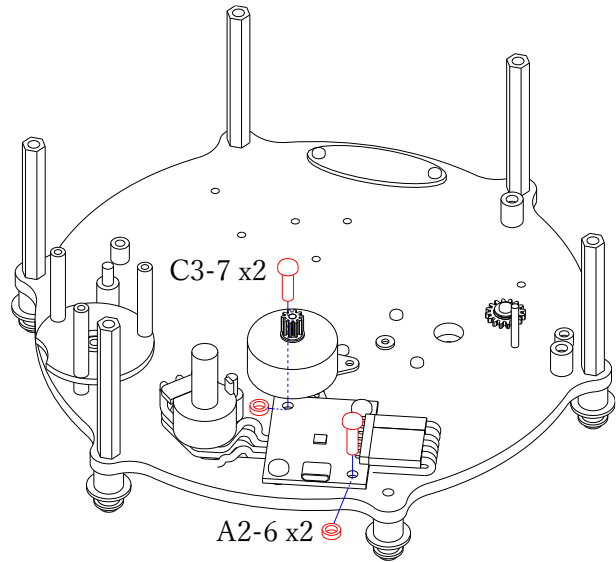

43. Slide A2-6 into the gap beneath H1 (motor controller) and pass the screw (C3-7).

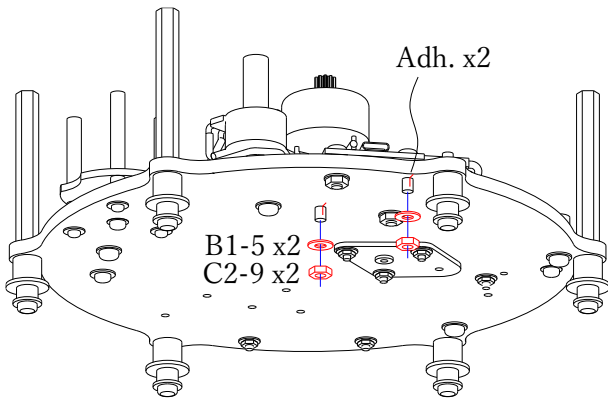

44.

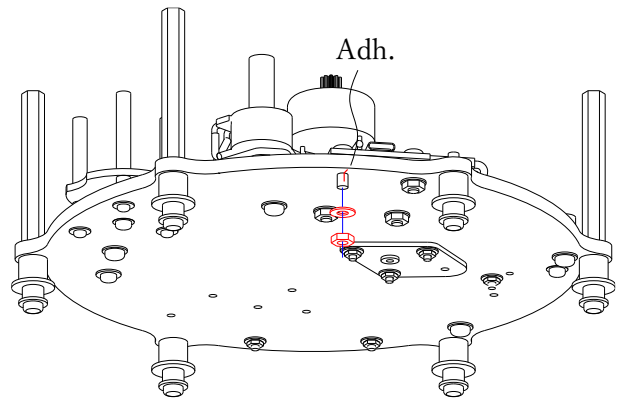

45. Remove B1-5 and C2-9 from tightened in Step 41, apply adhesive to the screw (C3-7), and reinstall. Then hold all four C2-9 by hand and tighten C3-7.

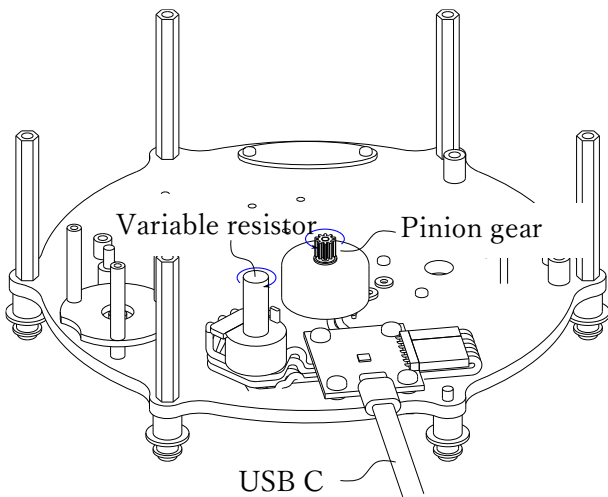

46. Connect the USB-C cable and rotate the variable resistor clockwise. Confirm that the power turns on with a click and the pinion gear rotates counterclockwise. If it does not move or rotates the wrong way, review Steps 36–38.

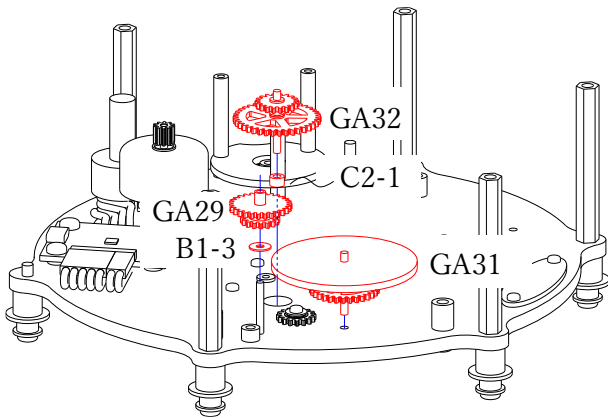

47. Pass GA32, GA29, and GA31 through the holes and shafts sequentially. Make sure not to forget C2-1 or B1-3.

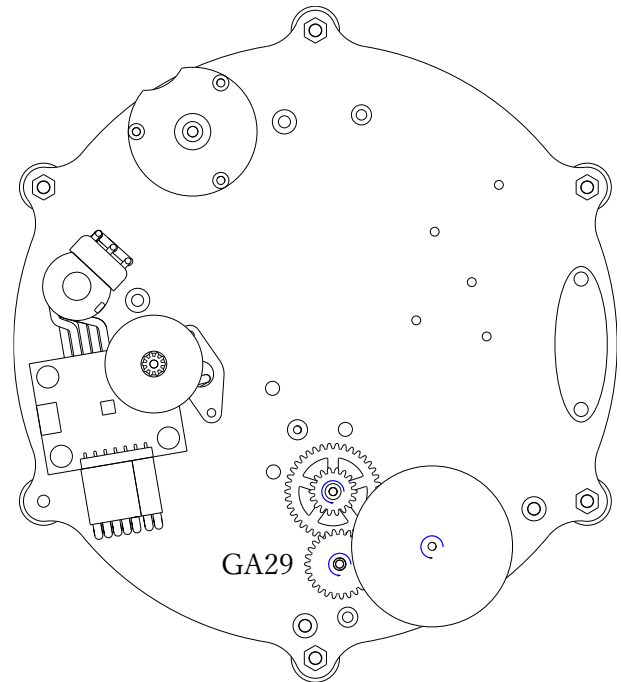

48. Rotate GA29 counterclockwise to ensure all gears rotate freely without obstruction.

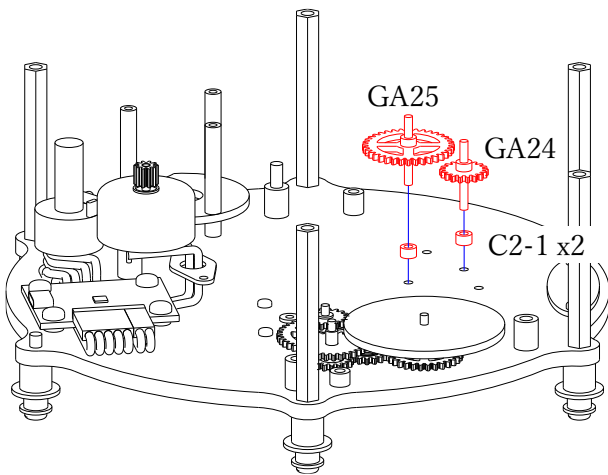

49. As in Step 46, pass GA24 and GA25 through C2-1 into the hole.

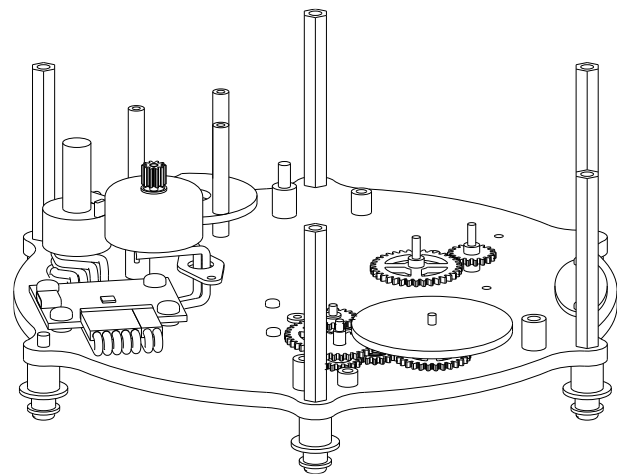

50. Complete

Final Assembly

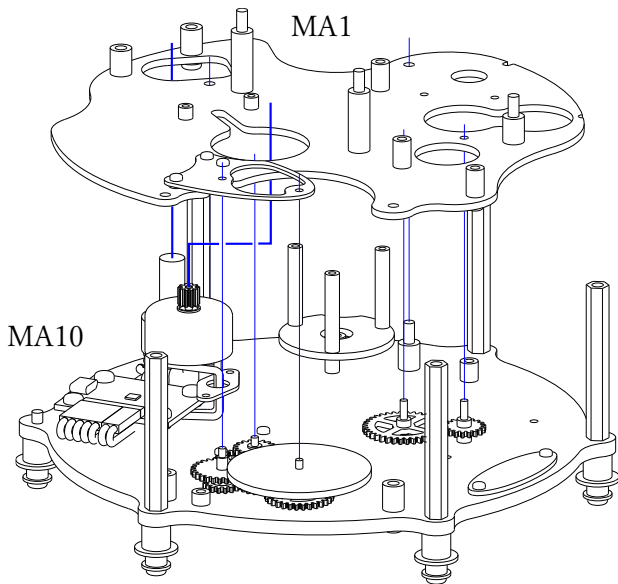

1. Refer to Steps 1 and 2 and assemble MA1 onto MA10. Route the motor and variable resistor of MA10 through the holes in MA1 so they extend above the panel.

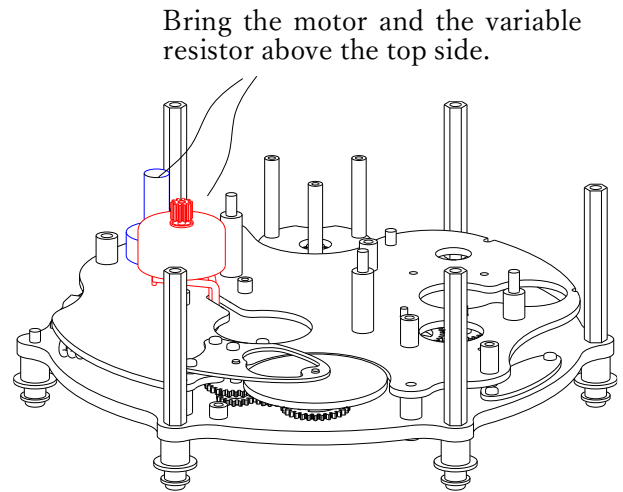

2. To prevent the sharp corners of the motor from scratching the surface of MA1, wrap a cloth or similar material around the motor for protection before working.

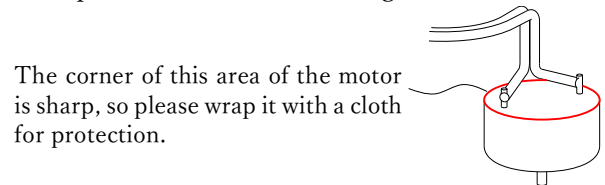

The corner of this area of the motor is sharp, so please wrap it with a cloth for protection.

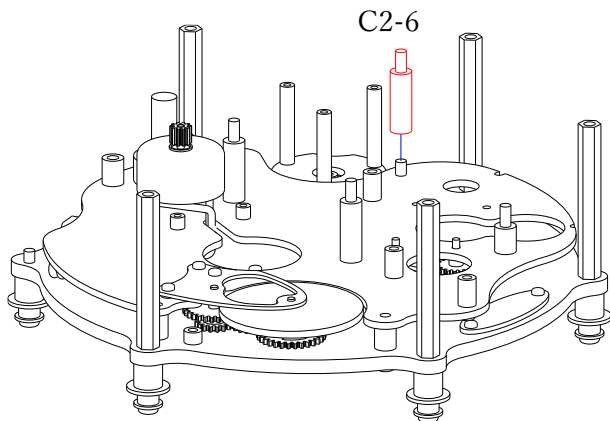

3.

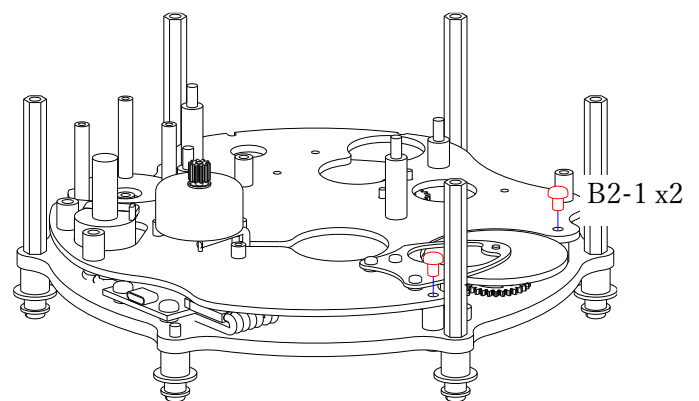

4.

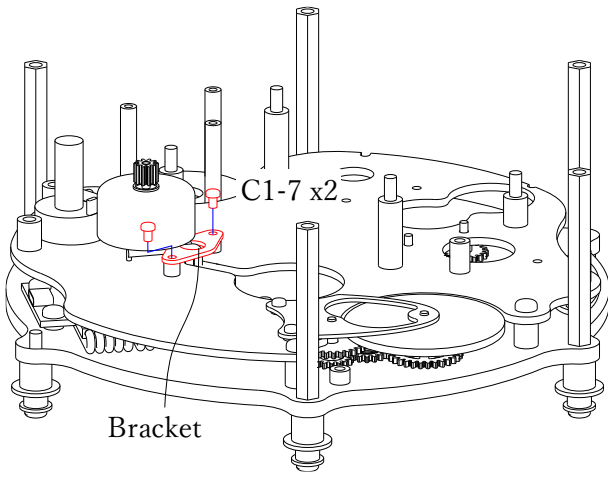

5. Pull out Bracket (D6) above MA1 and screw.

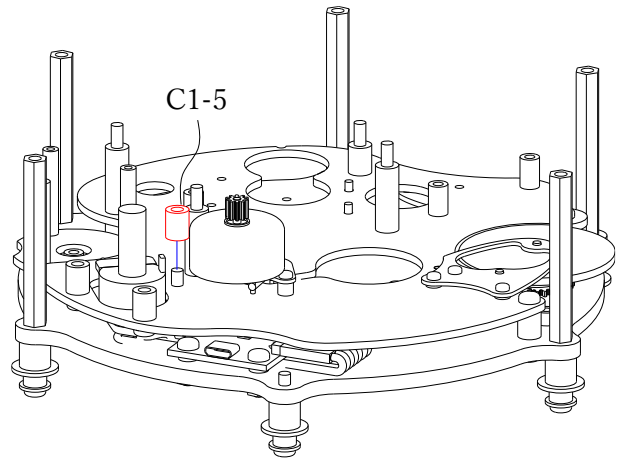

6.

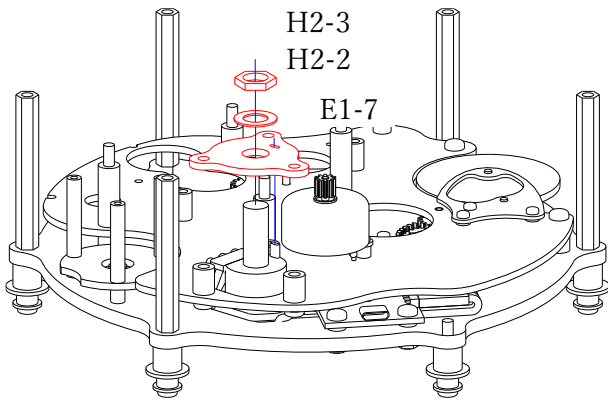

7. Tighten H2-3 using pliers. Be careful not to scratch E1-7 with the pliers.

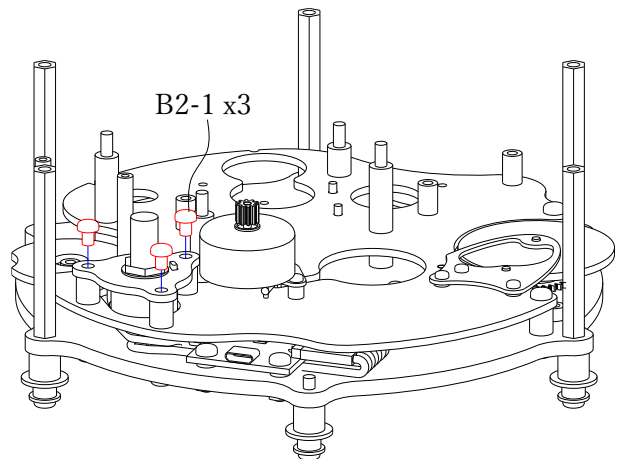

8.

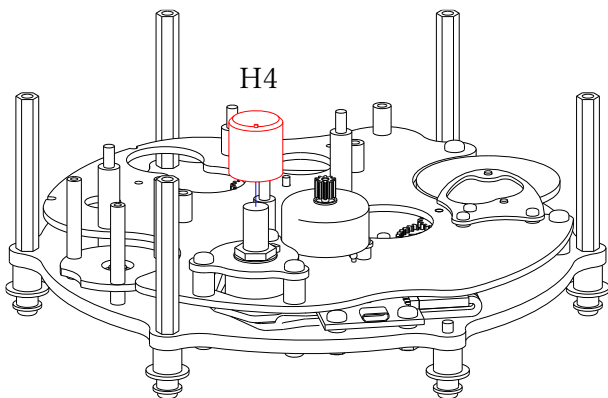

9. Turn the variable resistor fully counterclockwise, then press the knob (H4) in place in the direction shown in Step 11.

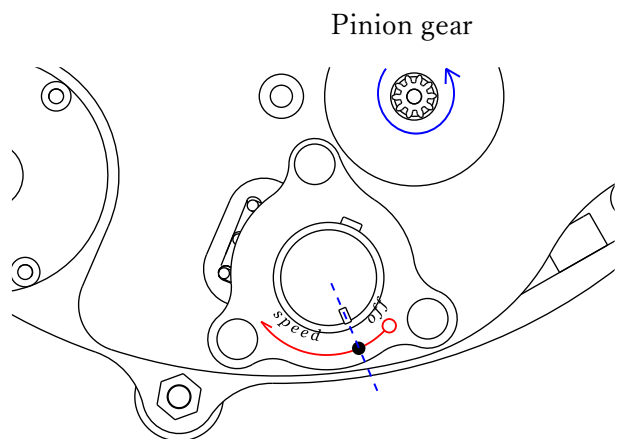

10. Align the notch of the knob toward the black dot in the diagram. If the inner groove of the knob and the groove of the variable resistor are not perfectly aligned, the notch and black dot may slightly deviate — this is not an issue.

After pressing the knob fully, connect the USB-C cable and turn the knob clockwise (toward “speed”). Confirm that the motor’s pinion gear (P6) rotates counterclockwise.

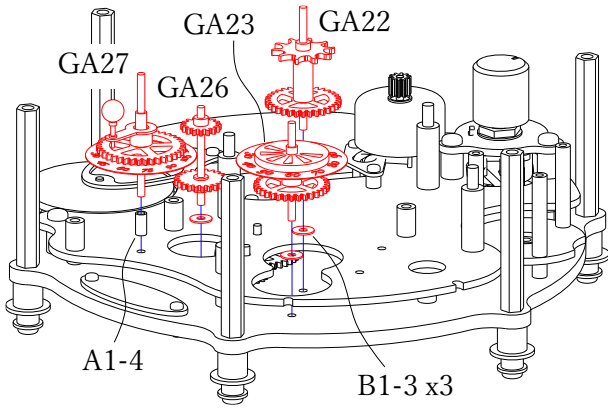

11. Assemble the time scale and Neptune mechanism.
Engage GA26 and GA27 together, and GA22 and GA23 together. There is no specific orientation for the gears.

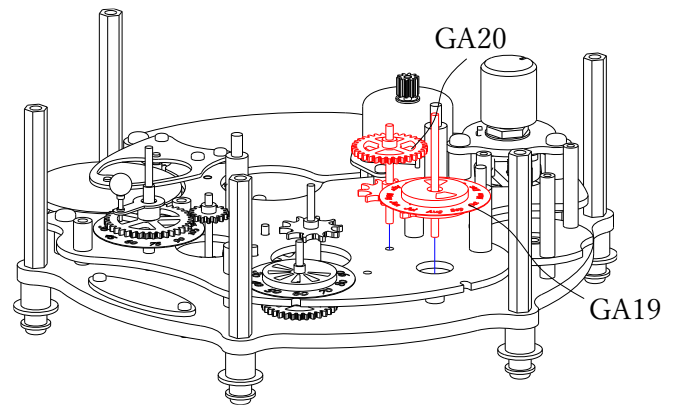

12. Similarly, engage GA19 and GA20 together. GA19's dial is prone to tilting or misalignment during assembly, so refer to GA19's assembly steps to correct any misalignment of the dial.

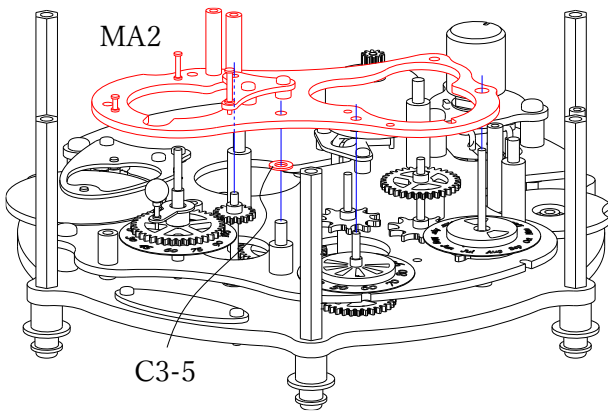

13. Attach MA2. GA20 may catch during assembly, so move it as necessary while attaching.
Be sure not to forget C3-5.

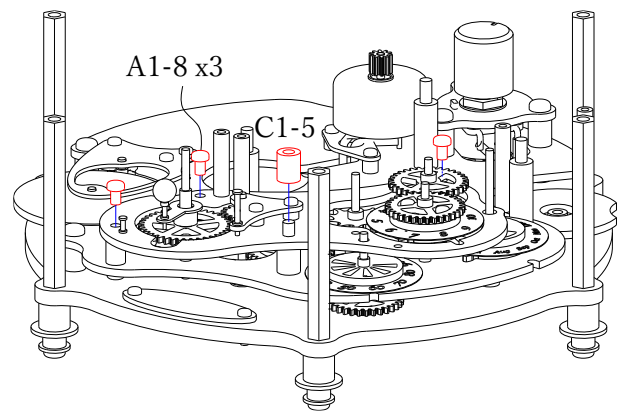

14. Lightly tighten the screws and rotate each gear by hand. If they move smoothly, tighten the screws firmly. If not smooth, check from the side to ensure the gears are meshing correctly.

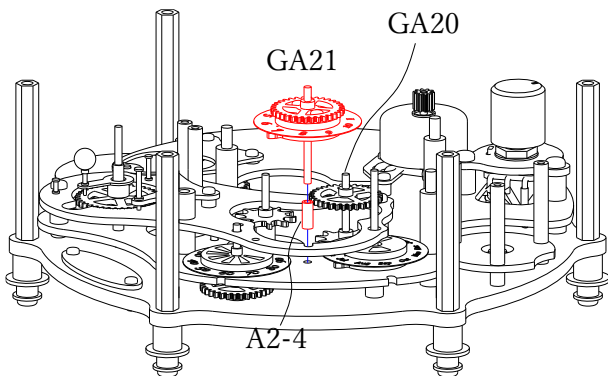

15. Tilt GA20 significantly toward the back side and attach GA21. Engage the teeth of GA21 with GA20 and GA22. After attaching GA21, return GA20 to its original position.

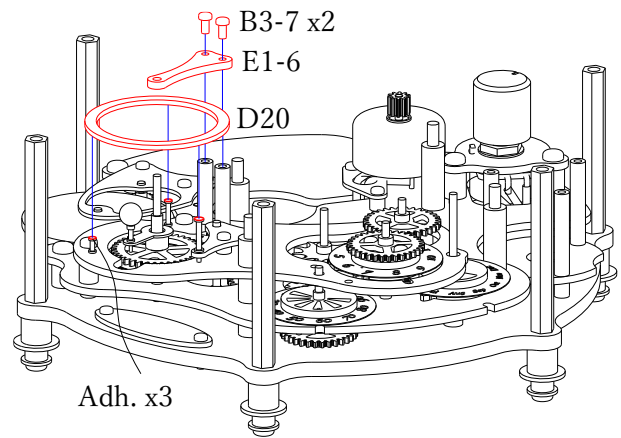

16. Attach D20 with the engraved side facing upward, placing the "PLUTO" engraving on the front, easily visible side.

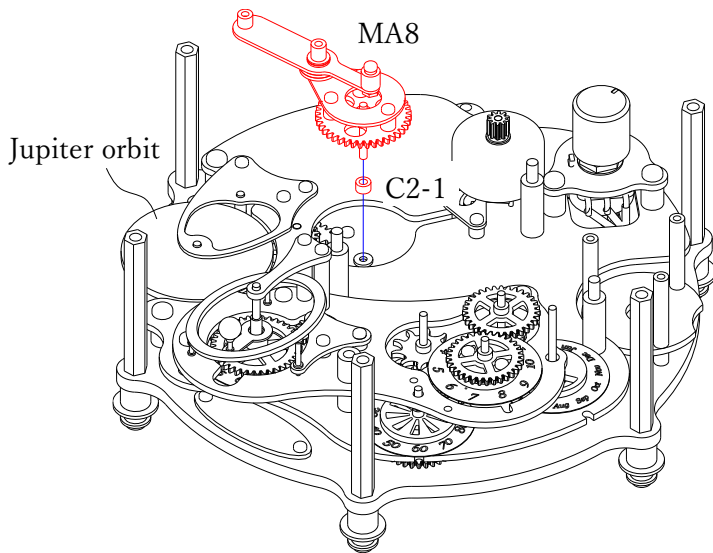

17. After attaching MA8, rotate MA8 clockwise by hand to confirm the Jupiter orbit moves smoothly.

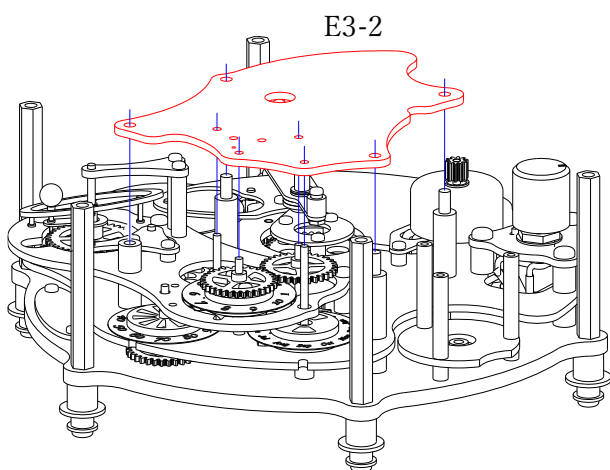

18. Attach E3-2. Move the motor as necessary so it does not interfere with E3-2.

GA19
(Month gear)

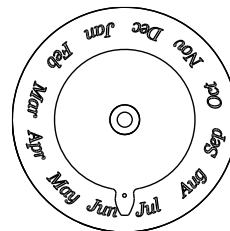

GA21
(Years gear)

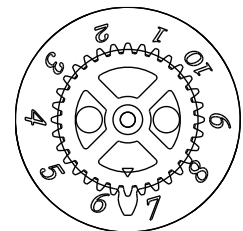

19. Confirm the following positions:

GA19: A tooth is centered between “Jun” and “Jul”

GA21: A tooth is centered between “6” and “7”

Adjust if misaligned.

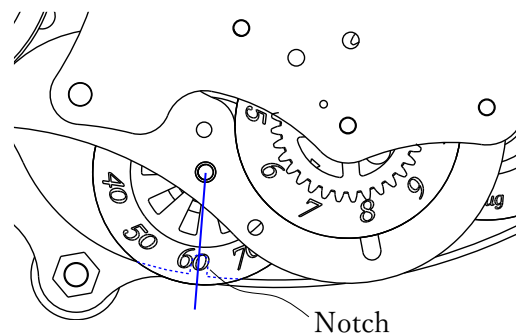
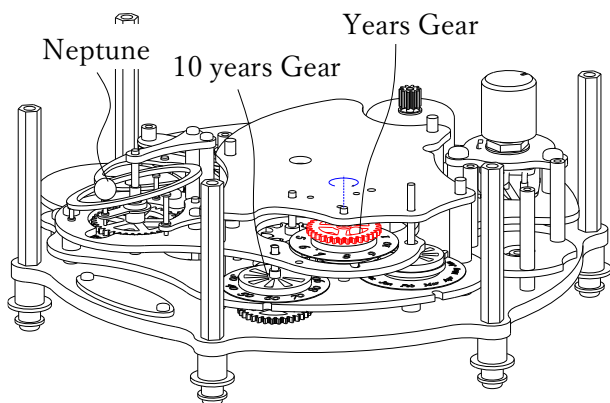

20. Slowly rotate the years gear clockwise. When the dial switches from 10 → 1, confirm that the 10-years gear and Neptune move one step. Hold the gear portion of the 10-years gear and rotate the dial so that the number aligns with the center of the notch. Repeat adjustment until proper alignment is achieved.

(The dial and gear will be bonded in a later step.)

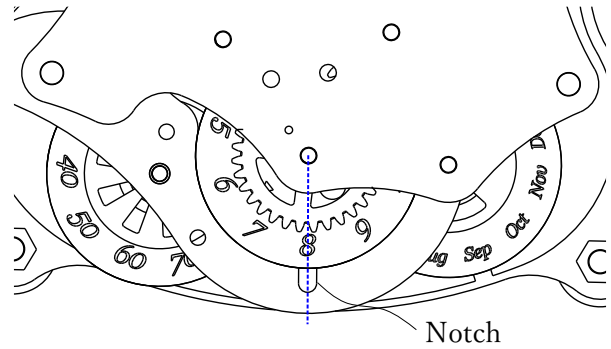
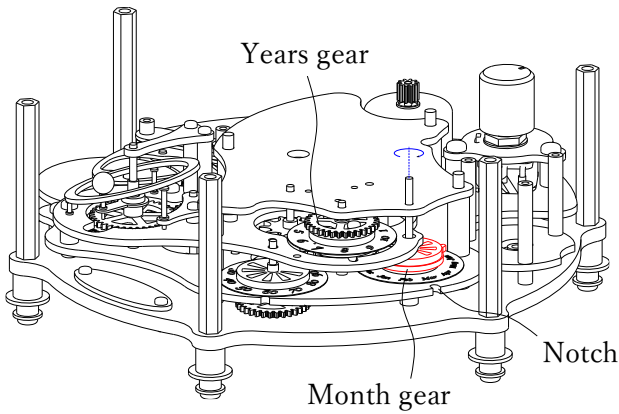

21. Slowly rotate the Month gear clockwise.
When the dial switches from Dec → Jan near the notch, confirm that the years gear moves one step.

22. Adjust so that the numbers on the Years gear are centered in the notch according to the following steps.

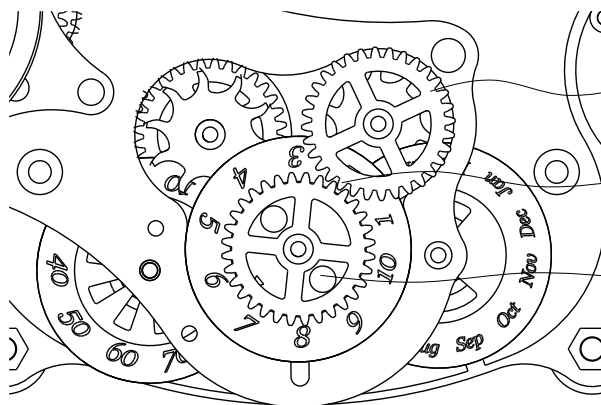

GA20
Disengage this engage section to adjust
Position the screw near the center of the opening

- 23-1. Remove E3-2 (installed in Step 18) and adjust so the screw of the Years gear is positioned roughly in the center of the gear's cutout opening.
- 23-2. Tilt GA20 toward the back and disengage the engagement indicated in the figure. Rotate the Years gear to center the number in the notch, then return GA20 to its original position.
- 23-3. Reattach E3-2 and repeat Steps 23-1 to 23-3 until the numbers align as close as possible to the center.
- 23-4. If the number is still slightly off after Step 23-3, hold the gear portion of the Years gear and make a very small adjustment to the dial. A slight deviation of the screw from the center of the cutout is acceptable.

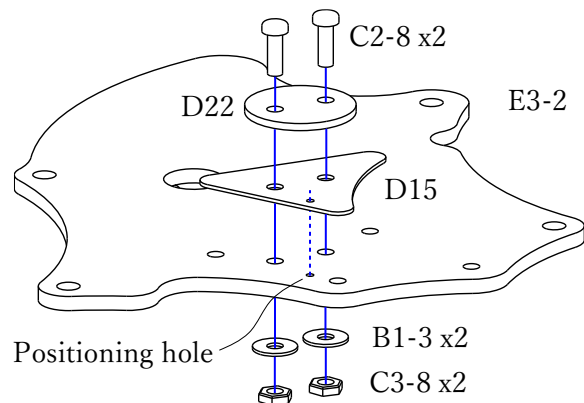
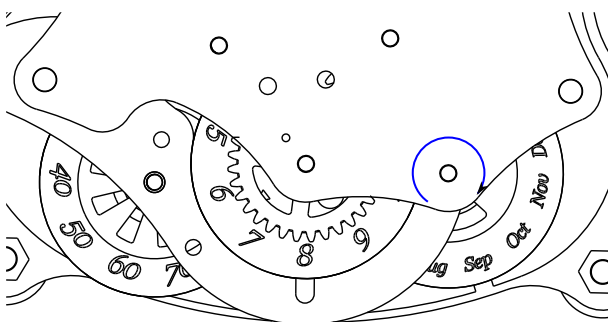

24. Slowly rotate the Month gear clockwise and confirm that the Years gear and 10-years gear each advance one step, with the numbers centered in the notch.

25. Carefully remove E3-2 without disturbing the gear alignment adjusted in Step 25, then fasten D15 and D22 with screws. (Note)

Note: The single-tooth gear of the Month gear and GA20 mesh only once per revolution. While gears are not meshed, GA20 is free to rotate and may shift due to vibration. If GA20 rotates unexpectedly when the single tooth arrives, the gears may collide and lock. Therefore, D15 is used to restrain the shafts of GA20 and surrounding gears to prevent unintended rotation. (The same applies to the single-tooth gear of the Years gear and GA22.)

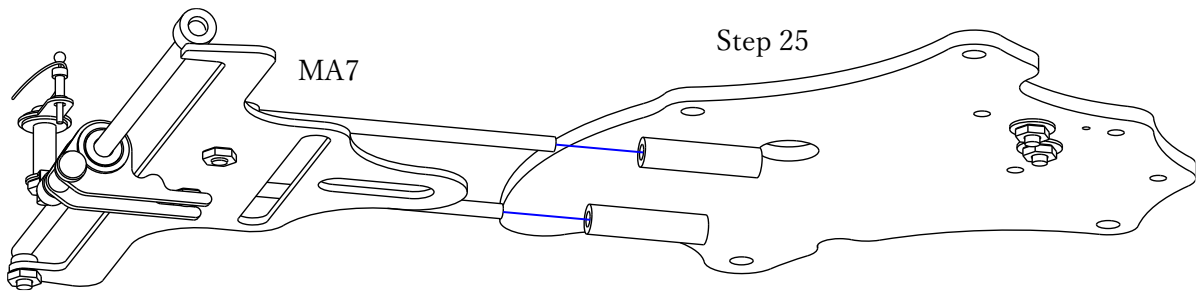

26.

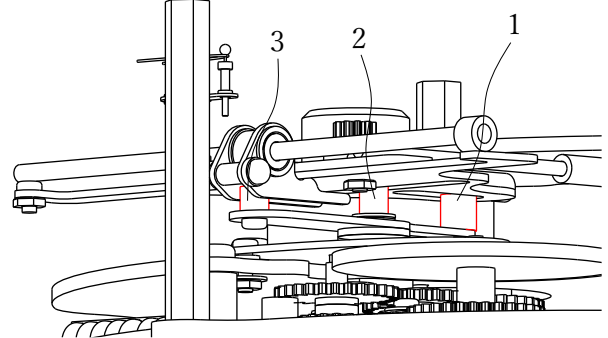
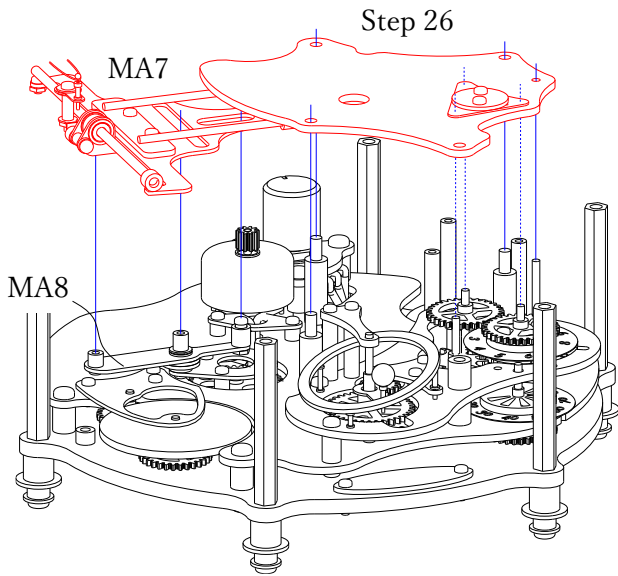

27. Carefully attach Step 26, making sure not to disturb the gear engagement adjusted in Step 24. At the same time, insert the three posts of MA8 into the three slots of MA7. (Move MA7 and MA8 as needed. See Step 28.)

28. Refer to the diagram and check that the three posts of MA8 are fully inserted into the slots of MA7. Step 26 will tend to lift up, so hold it down by hand until Step 30.

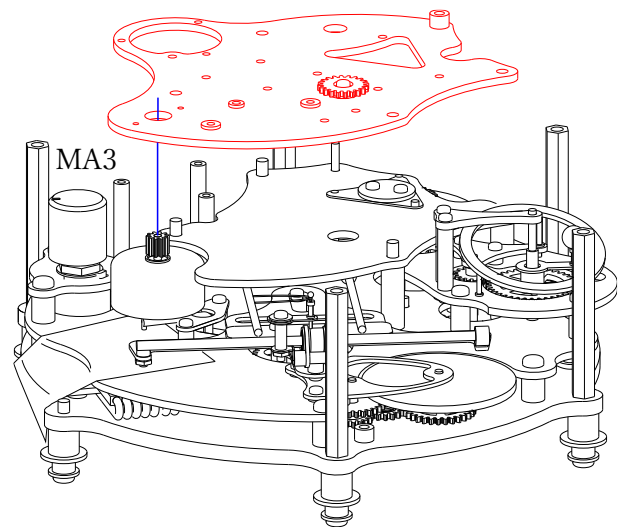
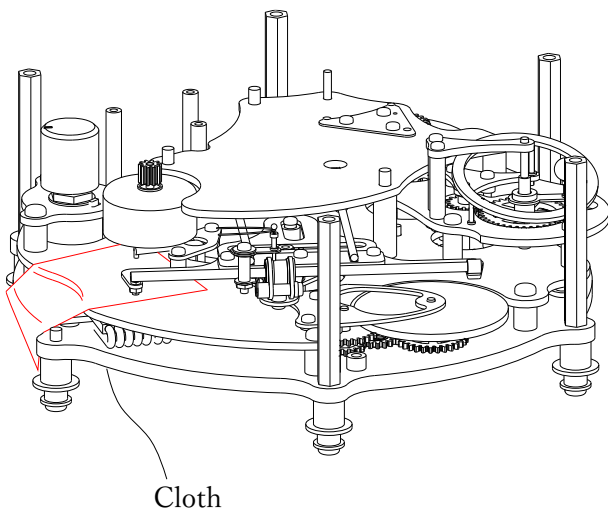

29. To prevent scratches on the panel during later steps, place a protective cloth between the motor and the panel.

30. Begin securing the motor.

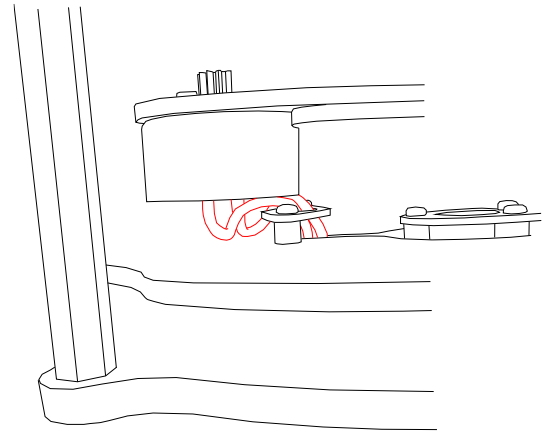
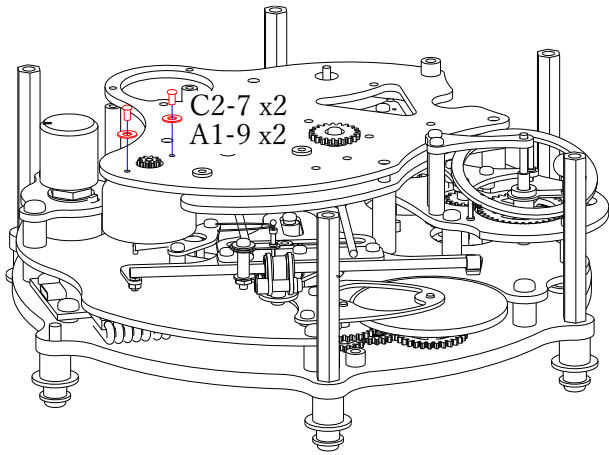

31. Align the screw holes of MA3 with the upper screw holes on the motor and fasten the motor. Several screw holes are available on the top of the motor—use the one that allows the motor cable to rest naturally without strain. Also, ensure the cable is routed to the left as shown, so it will not interfere with the motion of the comet in Step 35.

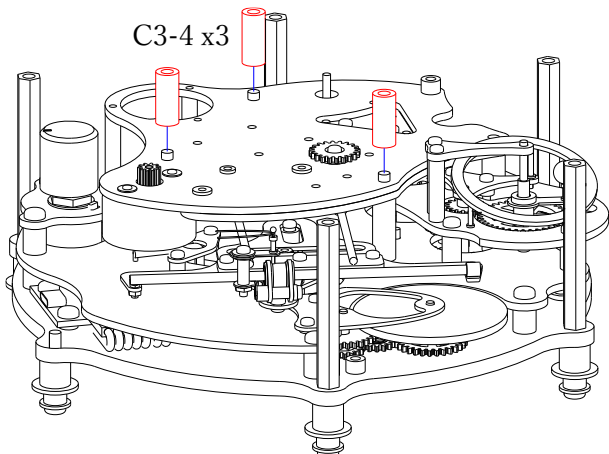

32.

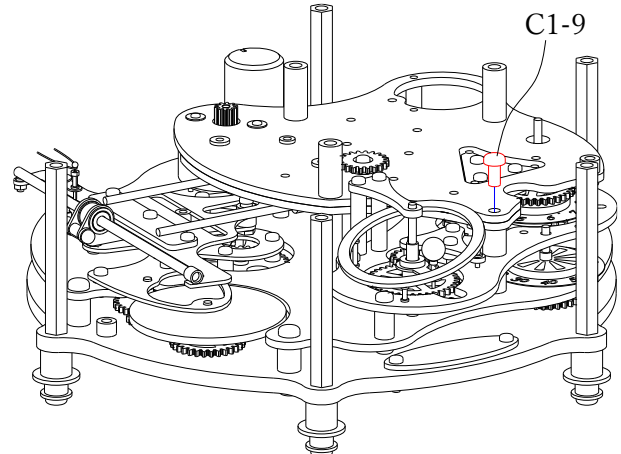

33.

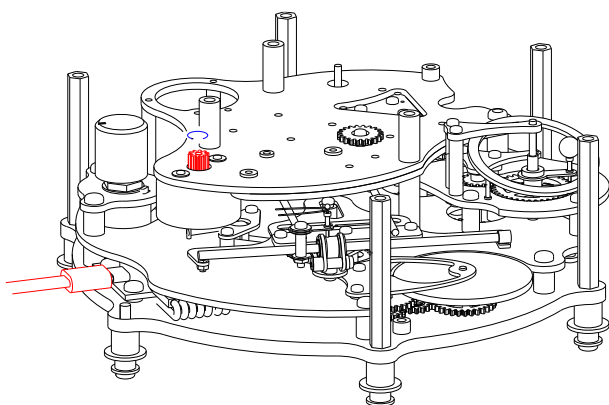

34. Remove the protective cloth, connect the USB cable, turn the knob to switch the motor on, and confirm the motor rotates counterclockwise smoothly without catching.

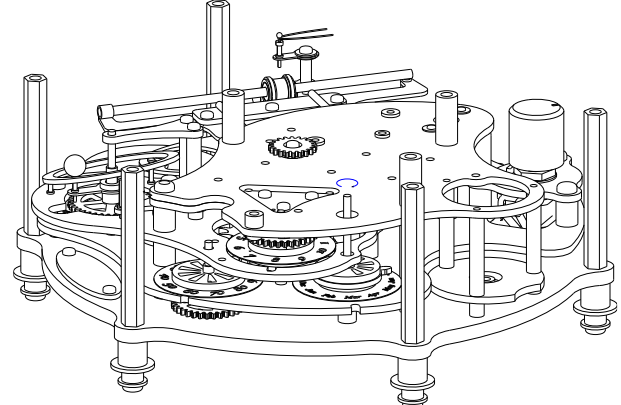

35. Check that the time scale alignment. Hold the shaft of the Month gear with pliers and slowly rotate it clockwise, confirming that the numbers on the Year gear and the 10-year gear align with the center of the notch. (Because the shaft is held by D15 from Step 25, rotational resistance will slightly increase when the digits switch, but this is normal.)

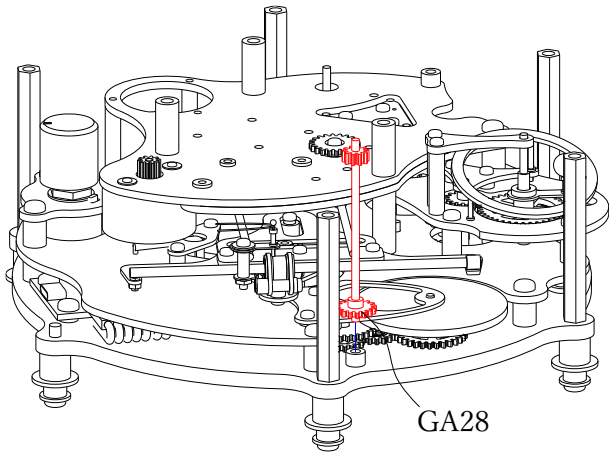

36. Check the comet's operation. Rotate the Stellar Movements so that the comet comes to the front and install GA28. (GA28 can easily fall over, so support it by hand.)

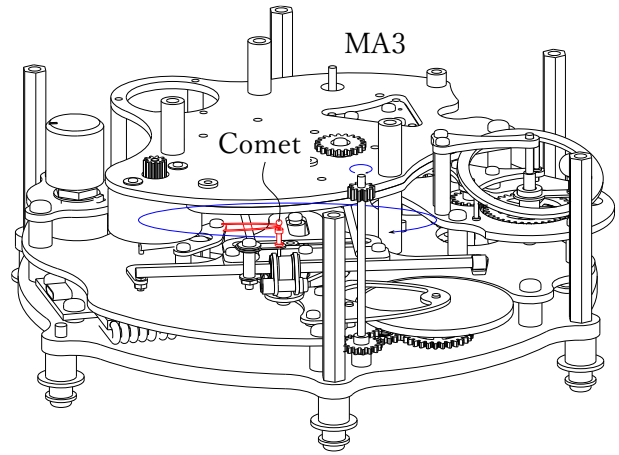

37. Turn GA28 clockwise and ensure the comet moves smoothly along its elliptical orbit. Remove GA28 after checking.

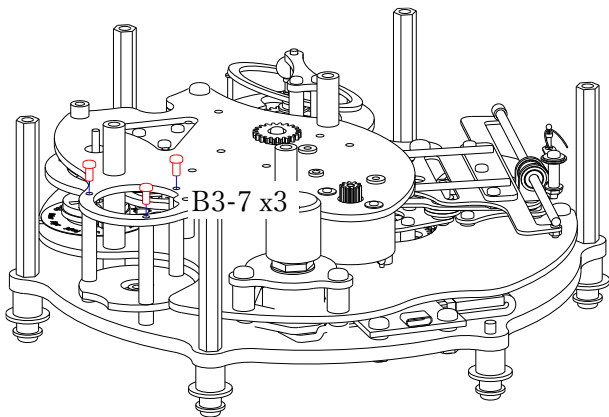

38.

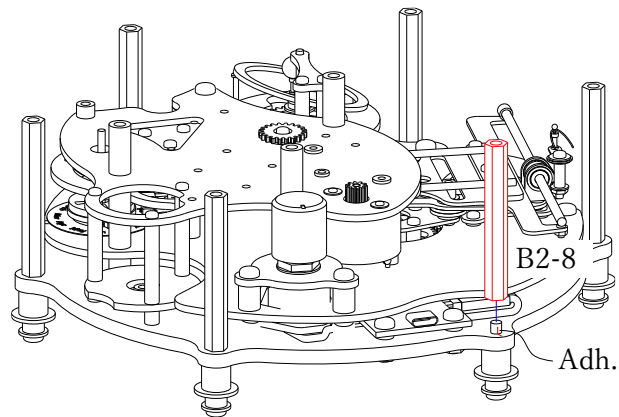

39.

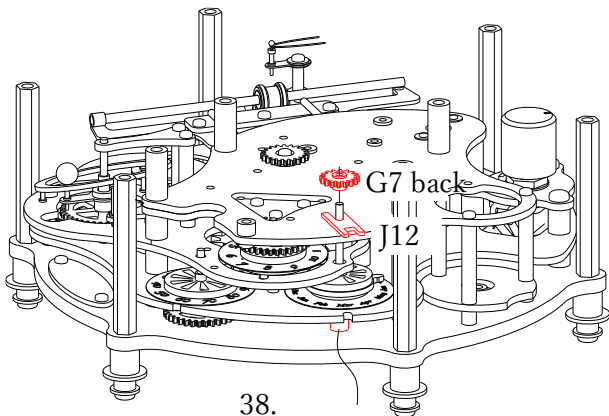

38.

Hold the screw on the back side

40. Insert the narrower gap of J12 onto the Month gear shaft. While holding the screw on the back side of the part shown in the figure, push the G7 gear until it contacts J12. Then remove J12.

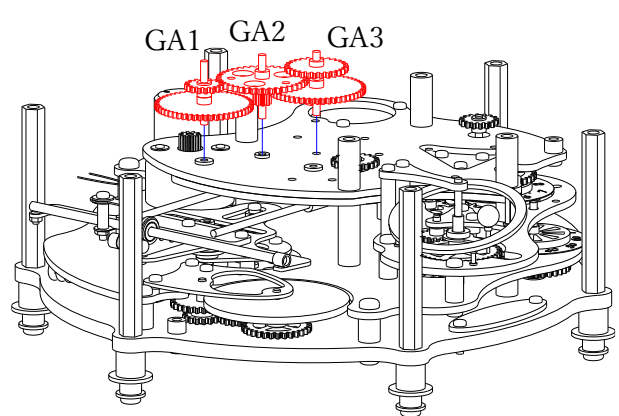

41. Assemble the reduction gear system.

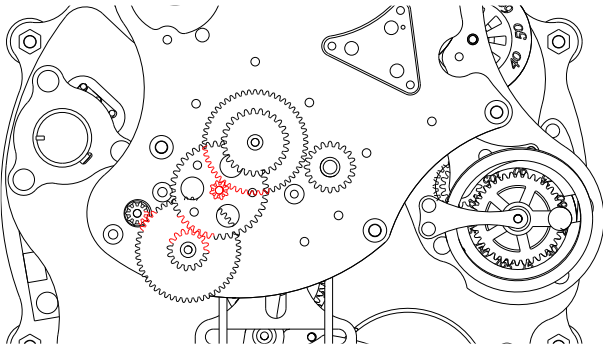

42. Engage the gears in the sequence indicated in red.

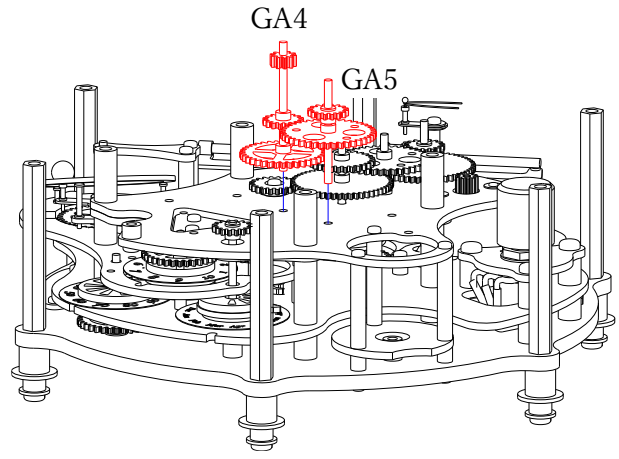

43. Attach the Earth drive gear GA4 and the branching gear GA5 that drives Mars, Jupiter, and the Moon phase.

The slightly shorter protruding side faces upward.

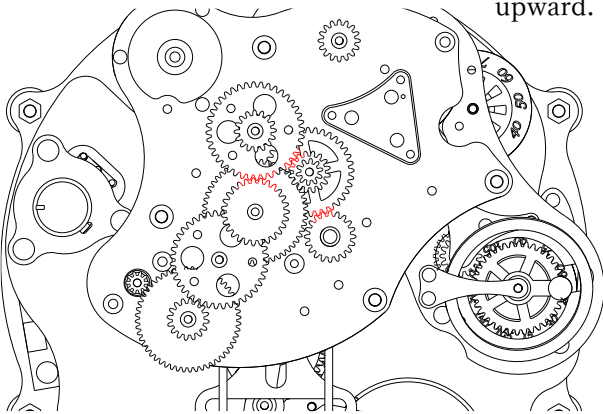

44.

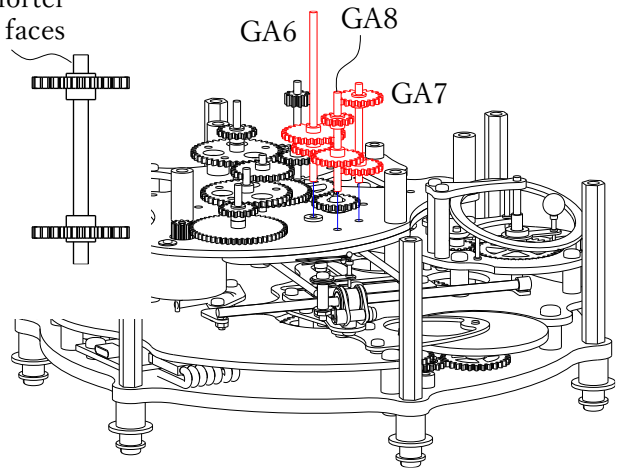

45. Attach the Mercury drive gear GA6, the gear GA7 that drives the Moon (see figure above), and the Venus drive gear GA8.

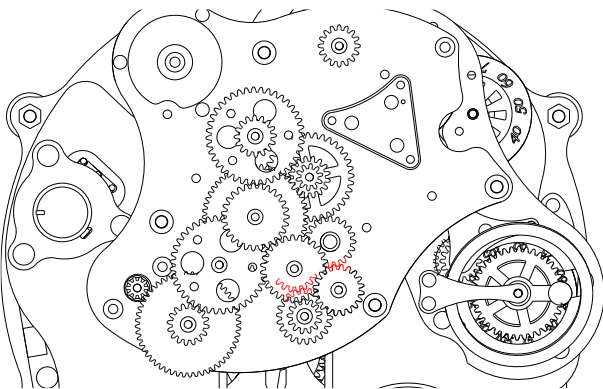

46.

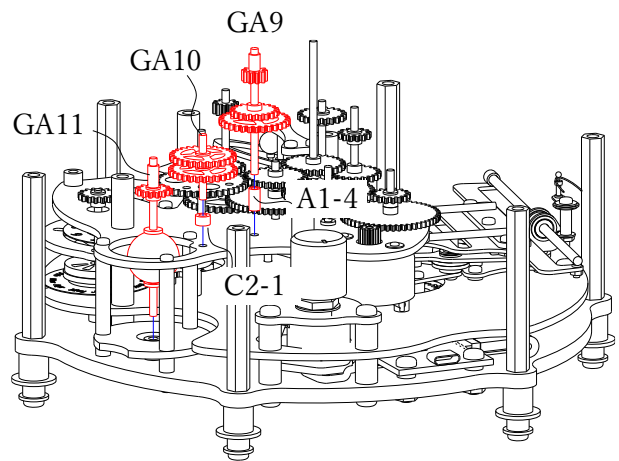

47. Attach the Mars drive gear GA9, the Lunar phase gears GA11 and GA10. (Lunar phase may slide downward, but it will be bonded later, so this is not a problem.)

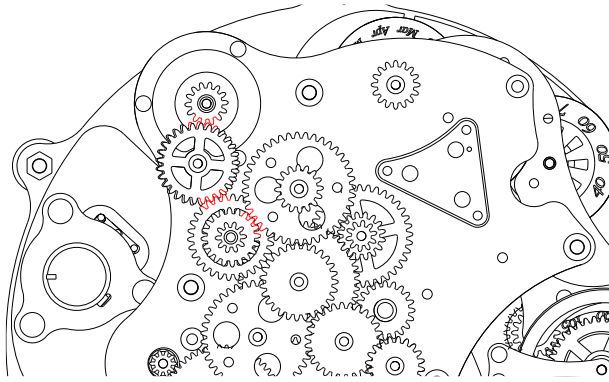

48.

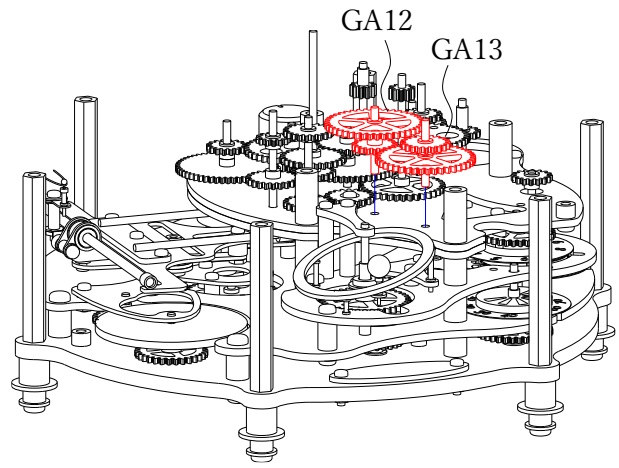

49. Attach the Saturn drive system gears GA12 and GA13.

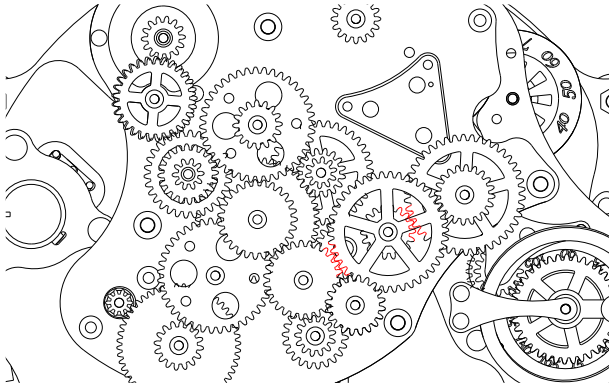

50.

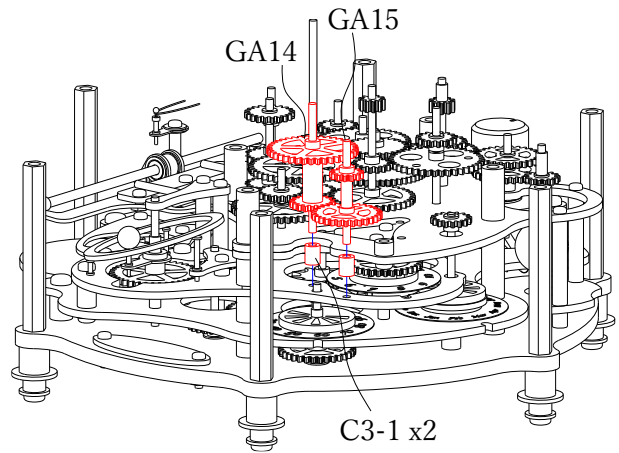

51. Attach the Saturn drive gear GA14 and the Uranus drive system gear GA15.

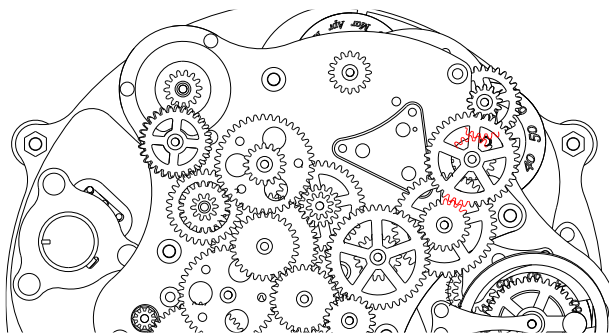

52.

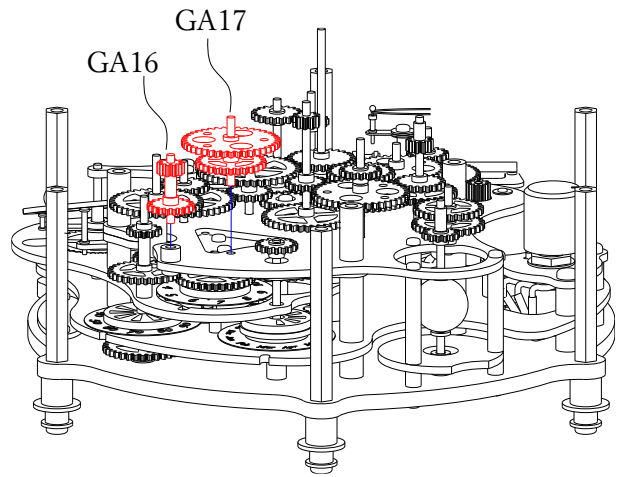

53. Attach the Uranus drive gear GA16 and the Time-scale coupling gear GA17.

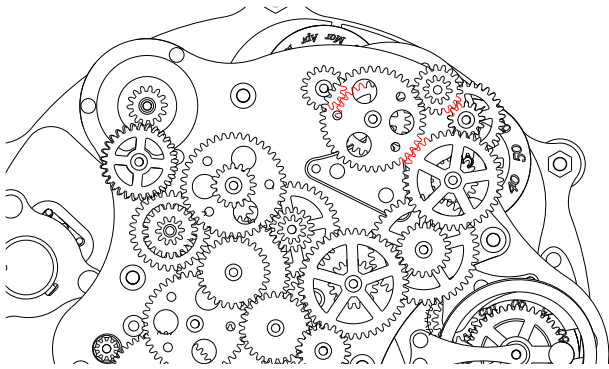

54.

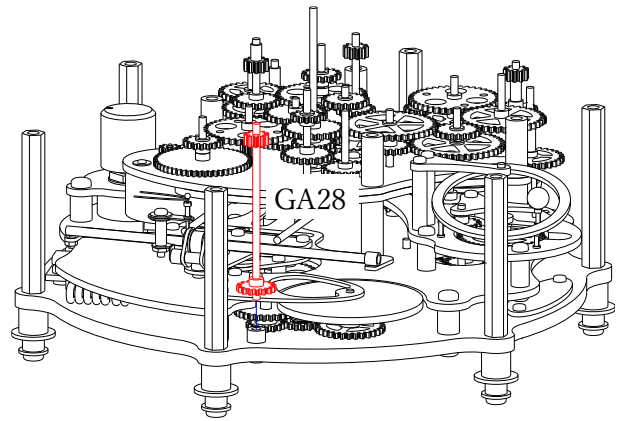

55. Attach the comet coupling gear GA28. Since it falls easily, install it just before Step 57.

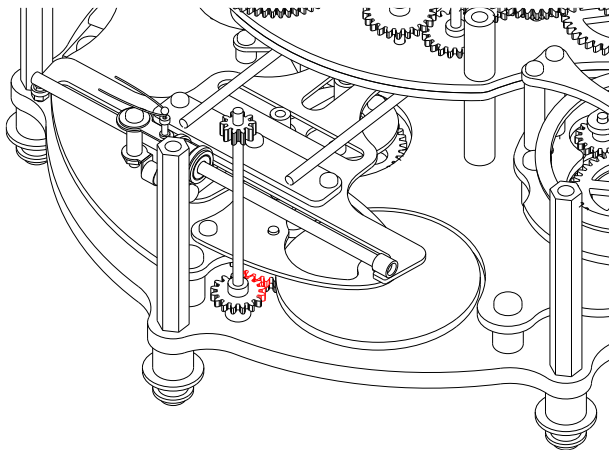

56.

MA4

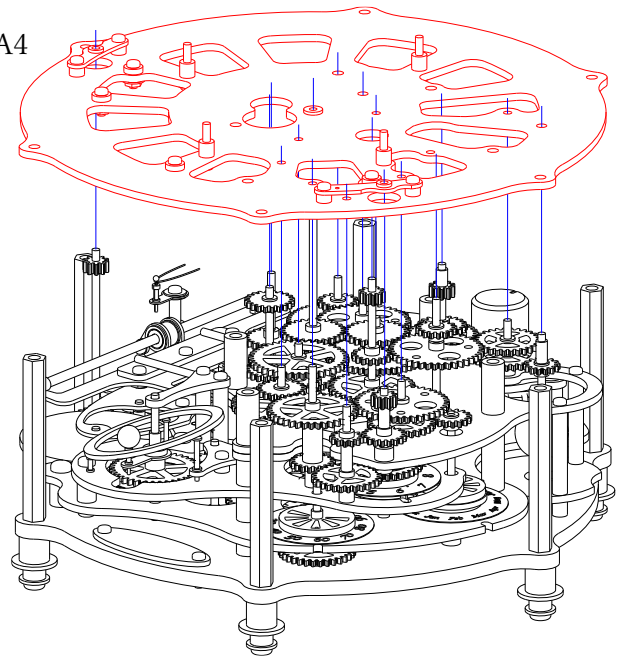

57. Insert each gear shaft into the holes of MA4. Take care, as the gears can easily fall over. (Start from the shaft protruding highest and insert them one by one into the holes.)

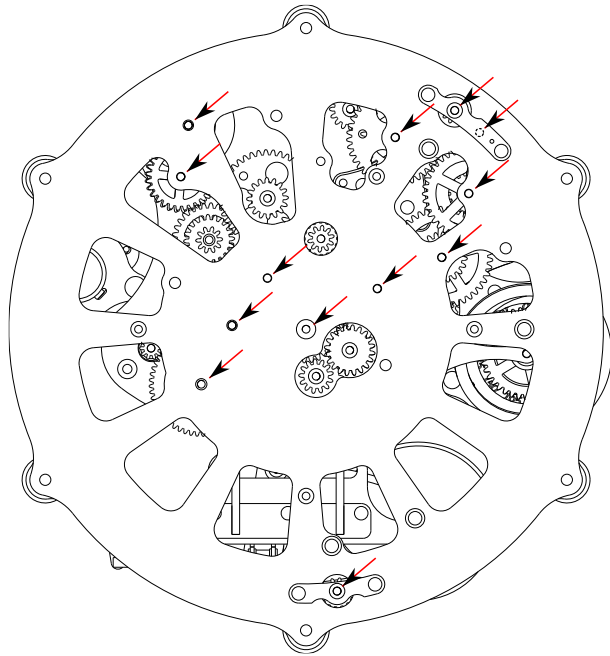

58. Top view
 (arrows indicate the MA4 hole positions where the shafts are inserted)

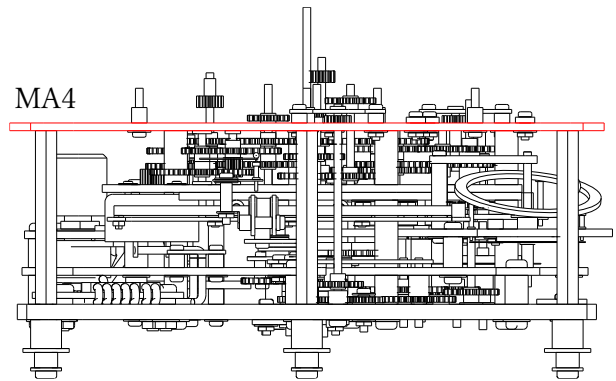

59. Side view
 Ensure the underside of MA4 is in contact with the six external hex pillars (B2-8) and the three C3-4 from Step 32. Due to board warping, MA4 may float slightly, but if it makes contact when pressed lightly, it is normal. If it floats excessively or remains tilted without making contact even when pressed lightly, check again for any shafts not inserted into holes or gears riding over other gears.

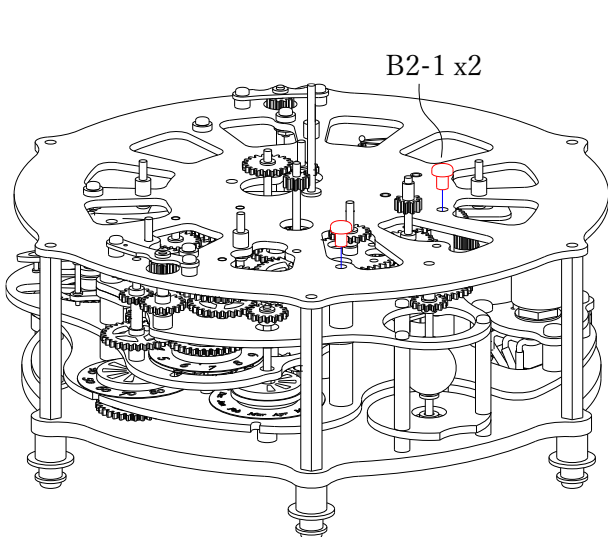

60. Lightly fasten MA4 with screws. Then rotate each gear slightly in the circumferential direction and confirm that they move freely with only the normal tooth clearance. If movement is not smooth or feels heavy, verify that no gears are riding over others and that all shafts are inserted correctly.

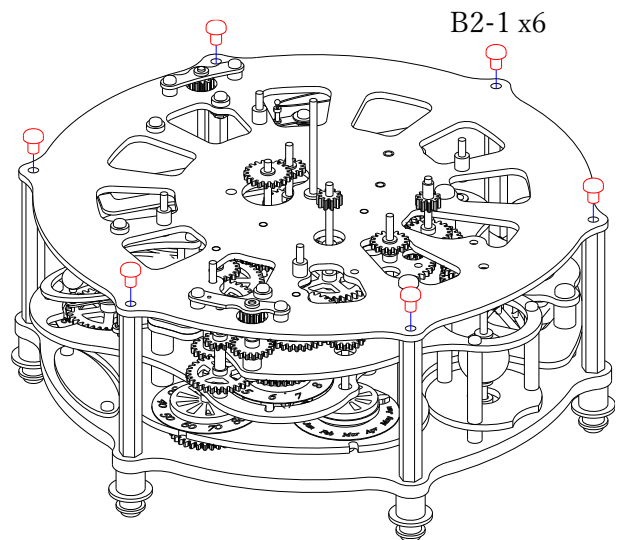

61. Fully tighten the screws from Step 60, and then firmly tighten the other six screws as well.

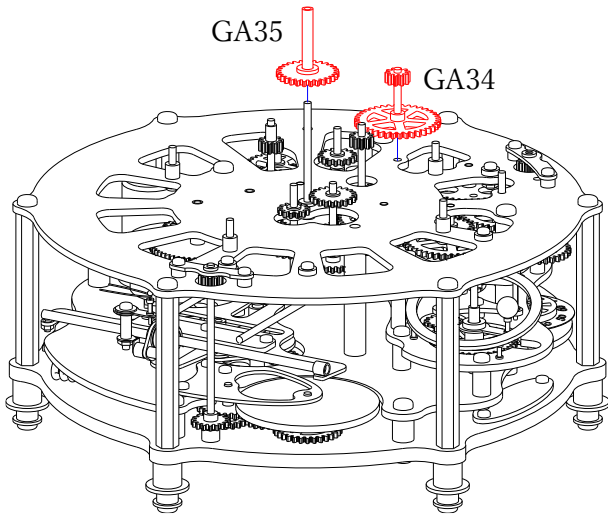

62. Attach the Venus gear GA35 and the Jupiter drive gear GA34.

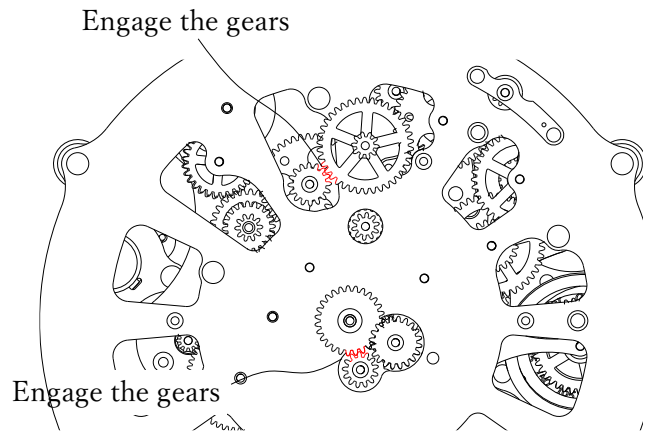

63.

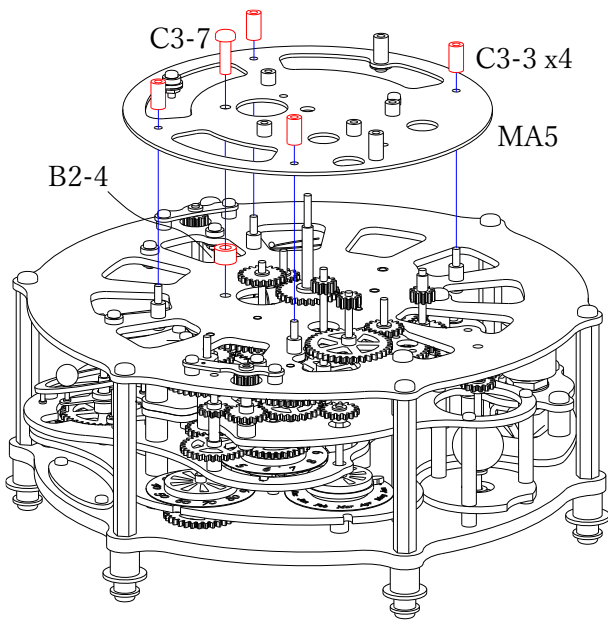

64.

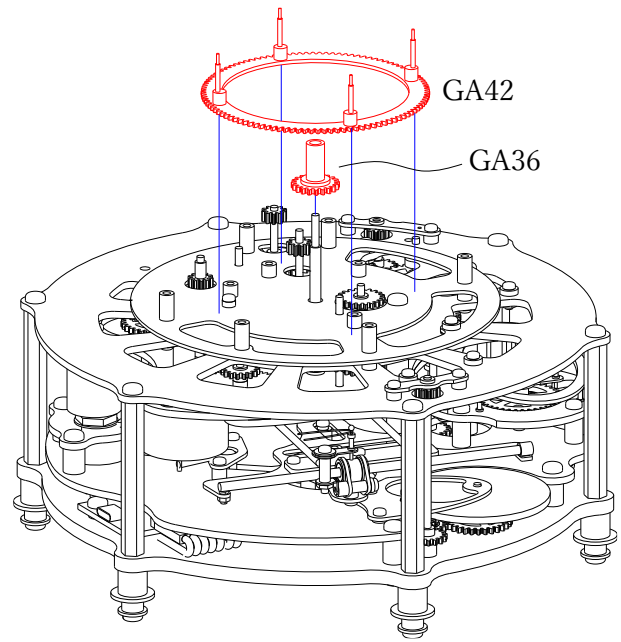

65.

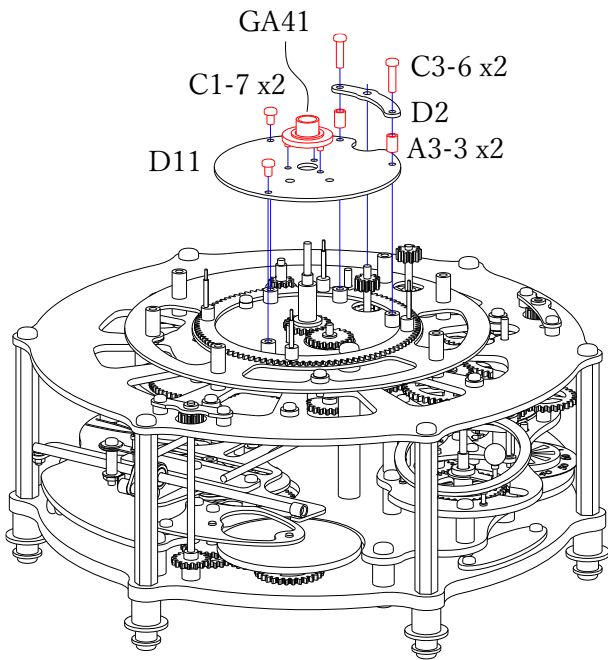

66.

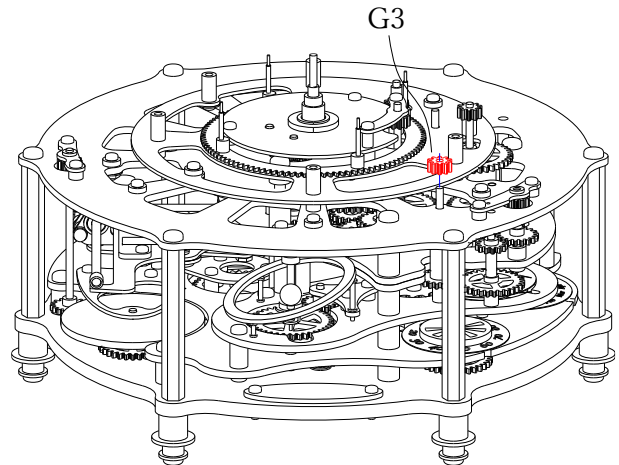

67. Push G3 onto the shaft while rotating it. Try to align the lower ends of MA5 and G3 as closely as possible, as shown.

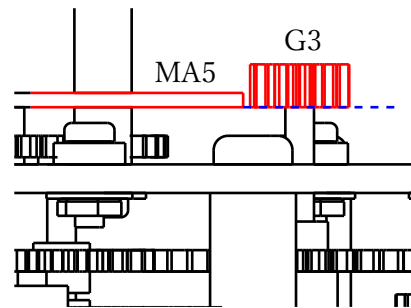

Engage the gears

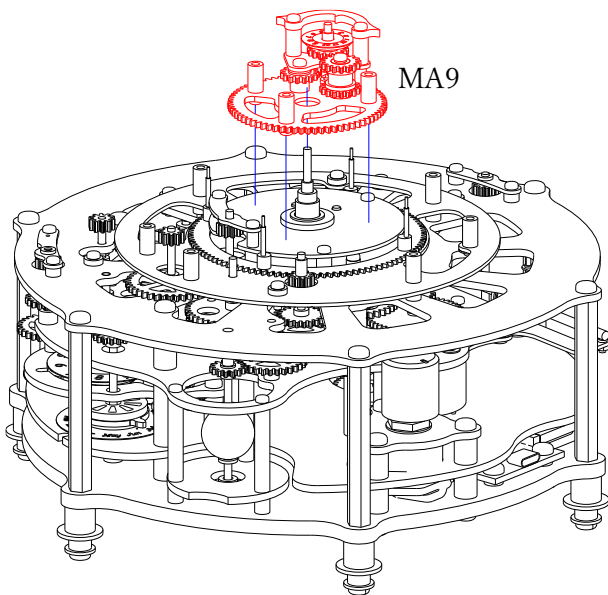

68.

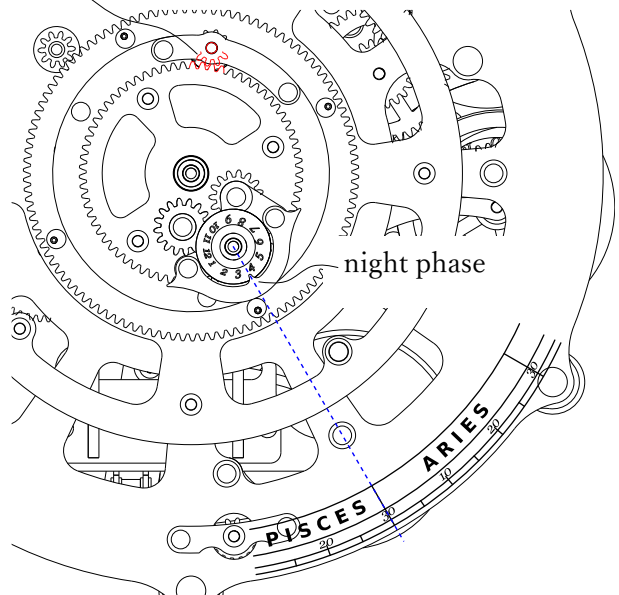

69. Engage MA9 with the Earth drive gear. Align the night-phase protrusion with the boundary between PISCES and ARIES on the Zodiac disc. (Approximate alignment is fine; fine-tuning will be done later.)

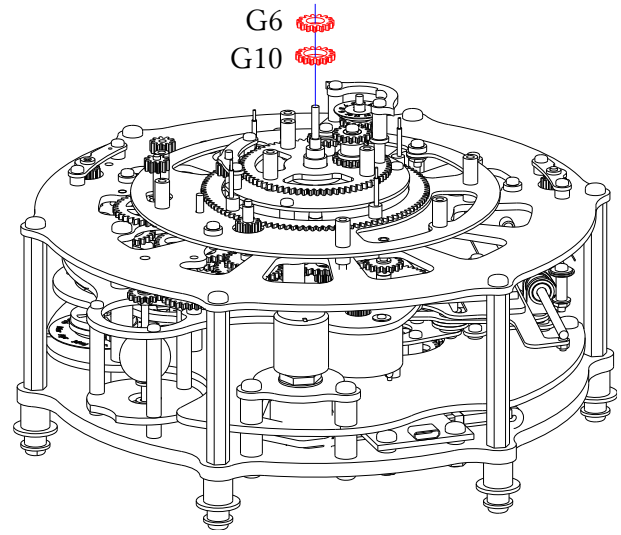
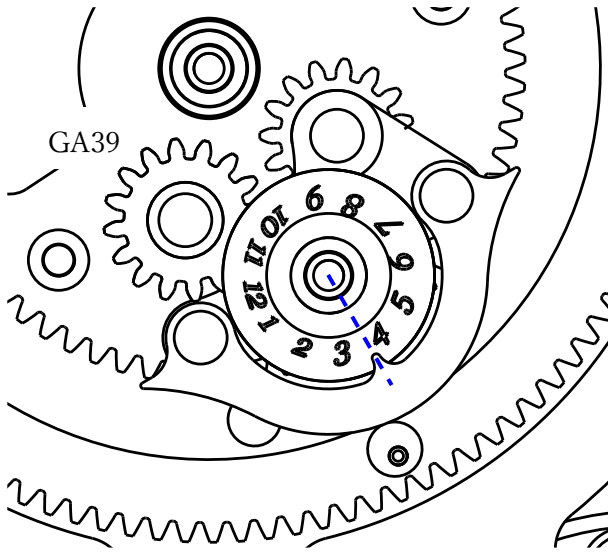

70. Rotate GA39 with tweezers and align around March 21 (the vernal equinox) of the calendar with the night-phase protrusion. (Approximate alignment is fine; fine-tuning will be done later.)

71. Attach G6 and G10. See Step 72 for details.

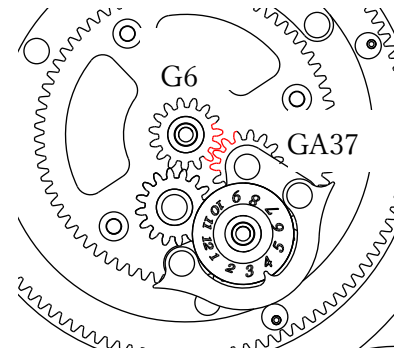
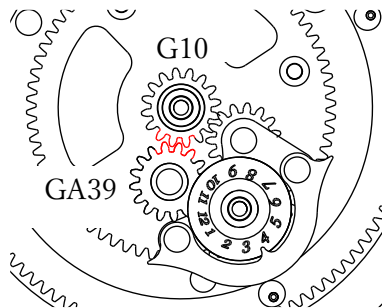
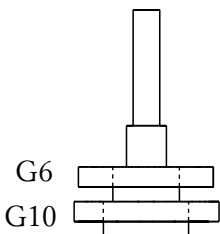

72. Place G10 onto GA41 from Step 66, hold the upper side of G10 with tweezers, and push it in (left figure). Then engage G10 with the gear below GA39 (center figure).

Similarly, push G6 onto GA36 from Step 65 and engage it with GA37 (left and right figures).

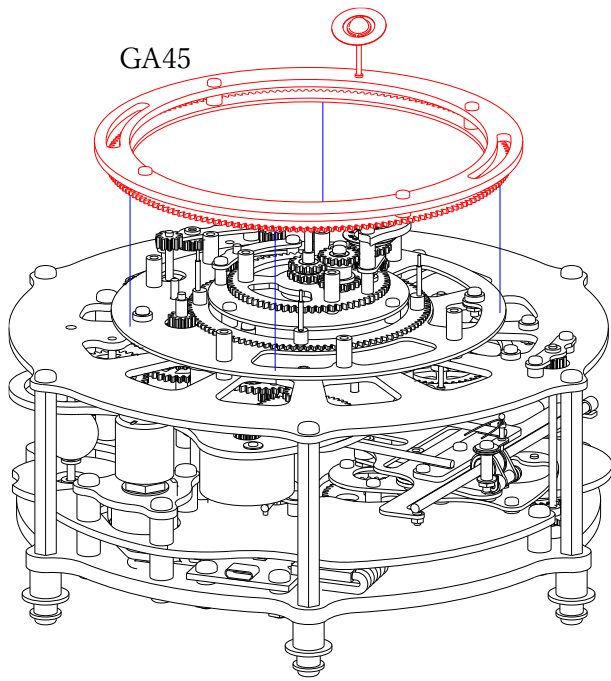

73.

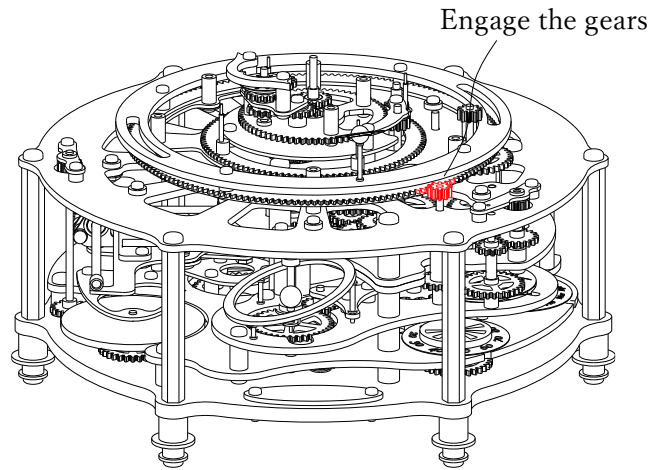

74. Engage the Saturn gear GA45 with the drive gear as shown.

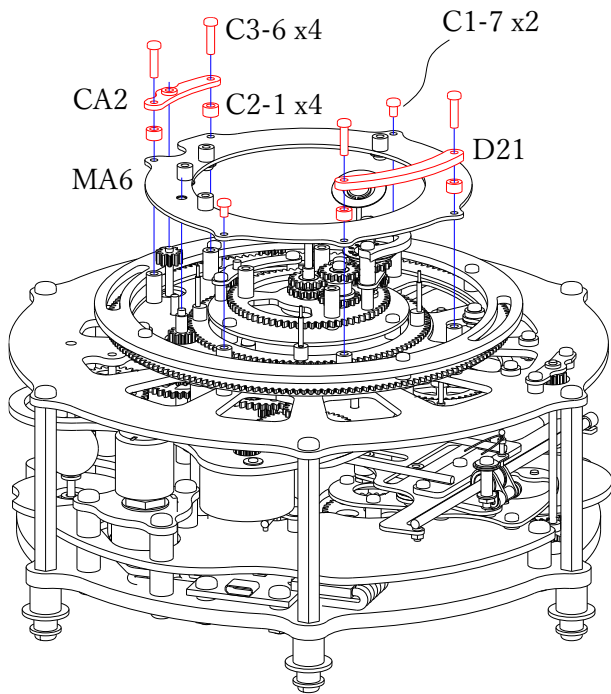

75.

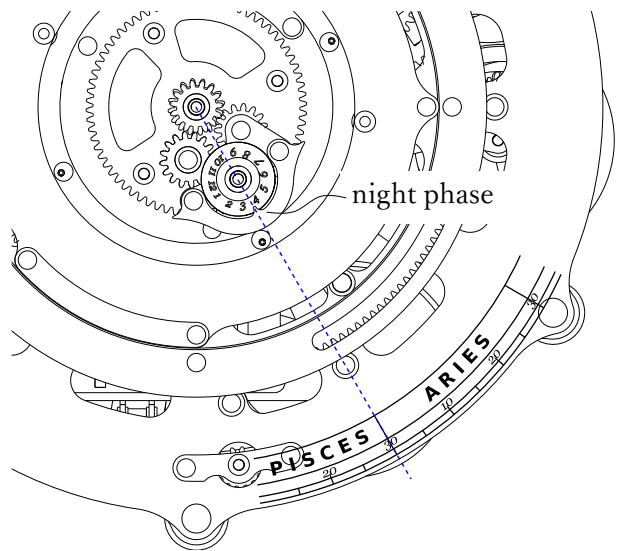

76. Connect the USB cable, turn the switch on, and rotate the Stellar Movements. As in Steps 69 and 70, align the night-phase protrusion and March 21 (vernal equinox) of the calendar with the boundary between PISCES and ARIES.

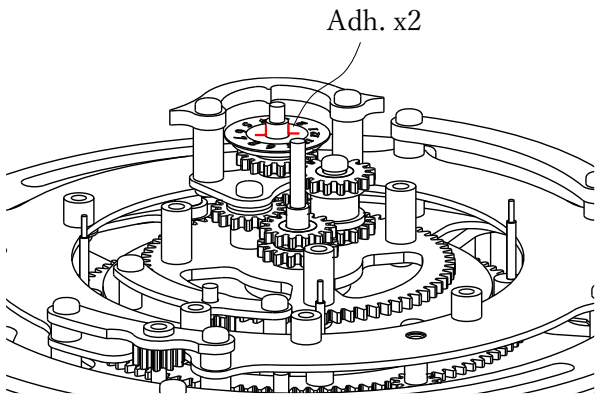

77. Stop the switch in the aligned condition of Step 76, apply adhesive between the calendar and the tube to secure the calendar. Take care not to get adhesive on the central shaft.

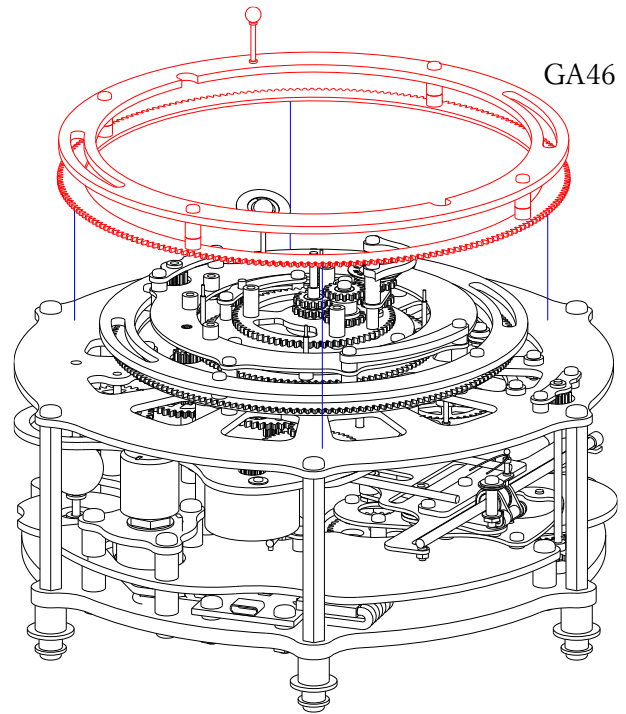

78.

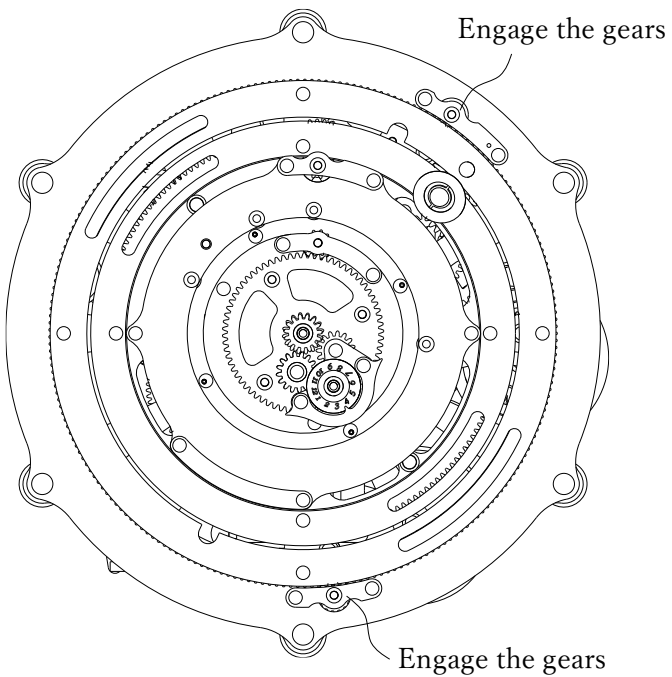

79.

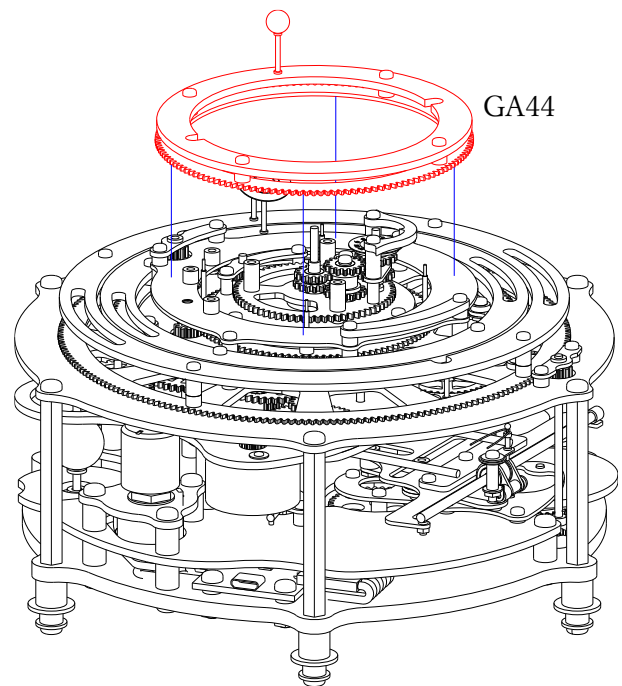

80.

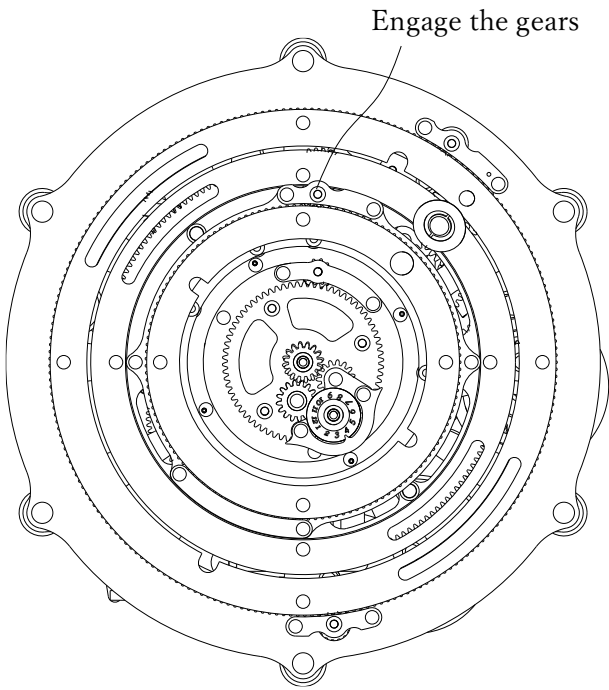

81.

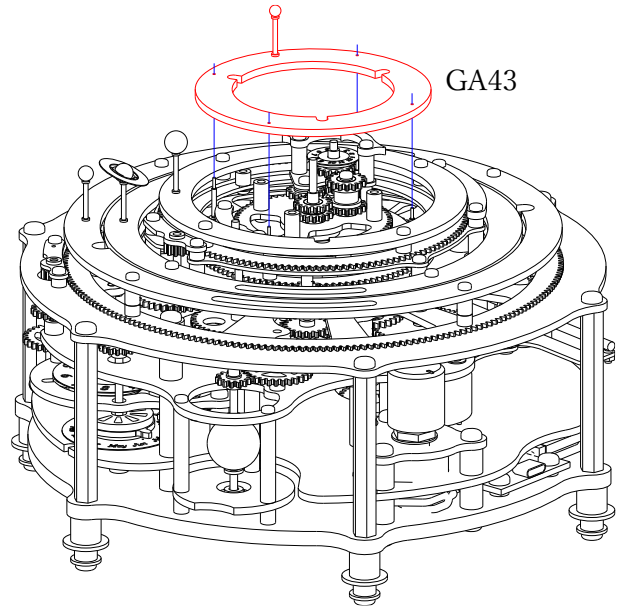

82.

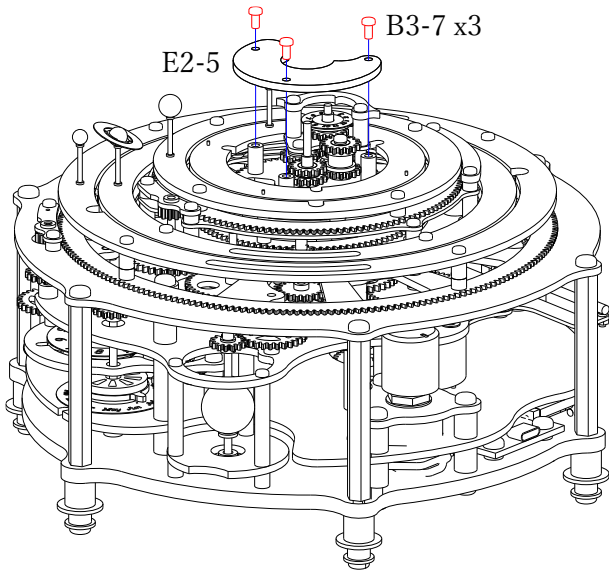

83.

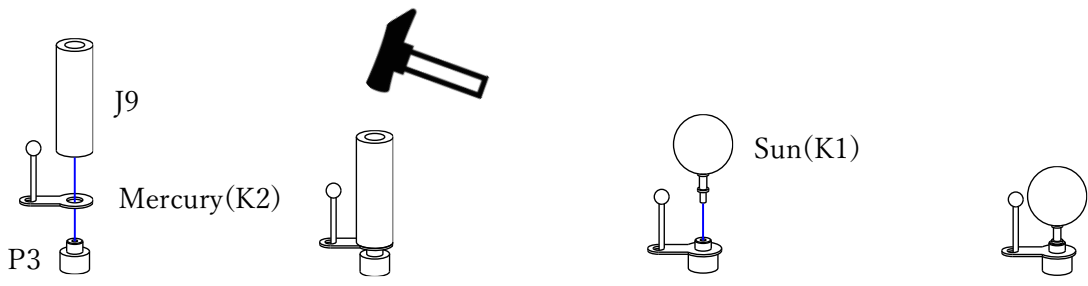

84. Assemble the Sun and Mercury.

85.

86. Be careful not to confuse the Sun (K1) with the Earth (K4), as they have similar shapes.

87. Complete

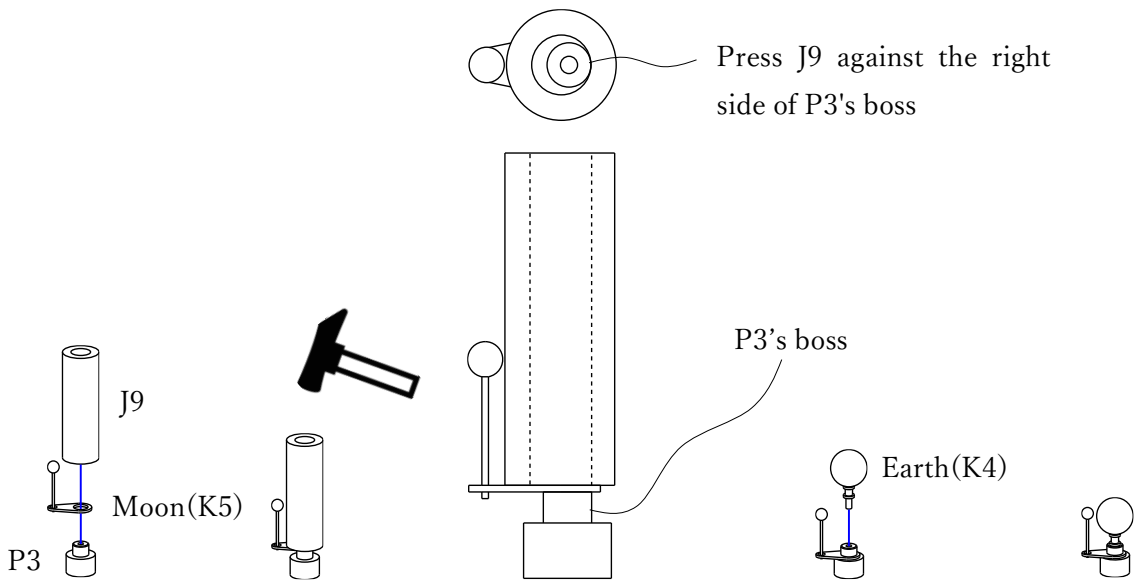

88. Assemble the Earth and Moon.

89. Press J9 against the right side of the boss on P3. (This prevents J9 from contacting the thinner section of K5 and deforming K5.)

90.

91. Complete

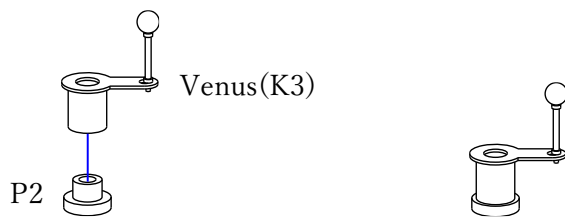

92. Assemble Venus. Press-fit K3 into P2.

93. Complete

Hold this section while pressing
in Step 91

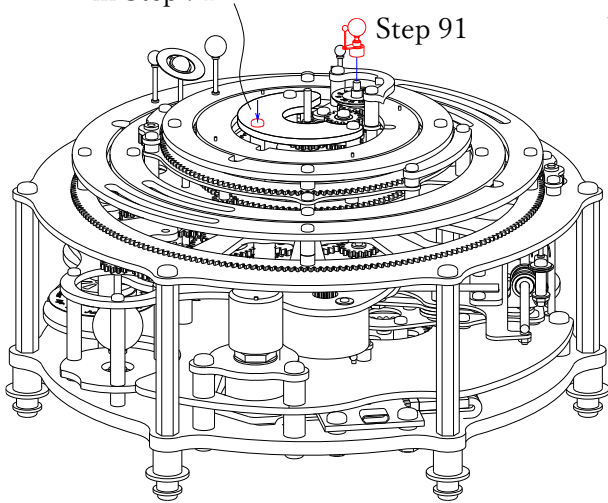

Press-fit here

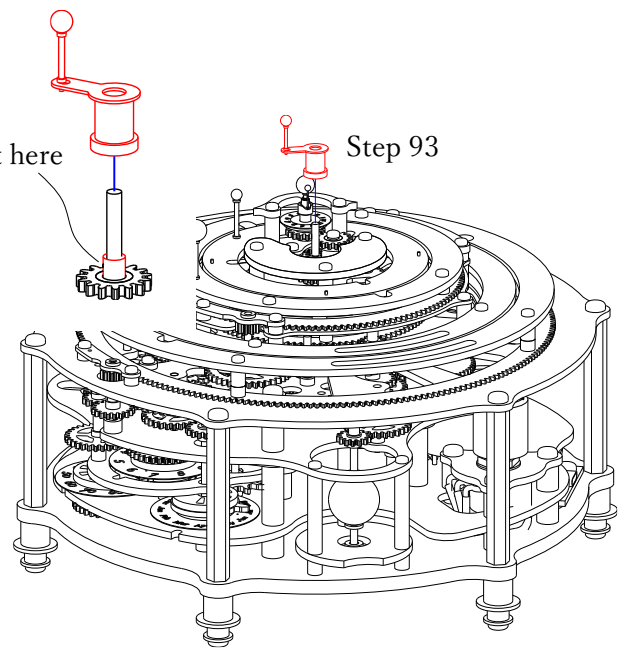

94. While holding the screw section shown in the figure by hand, press the Earth and Moon from Step 91 onto the shaft. (The orientation of the Earth and Moon will be adjusted in later steps.)

95. Press the Venus from Step 93 into place as shown in the figure.

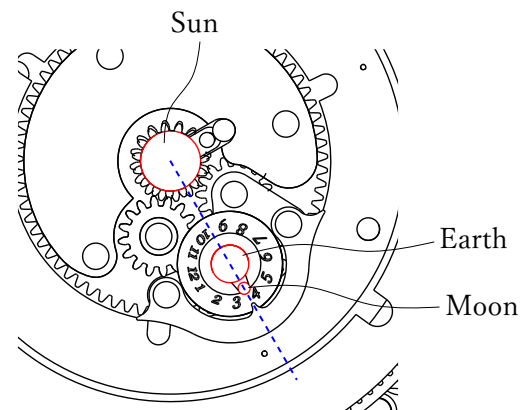
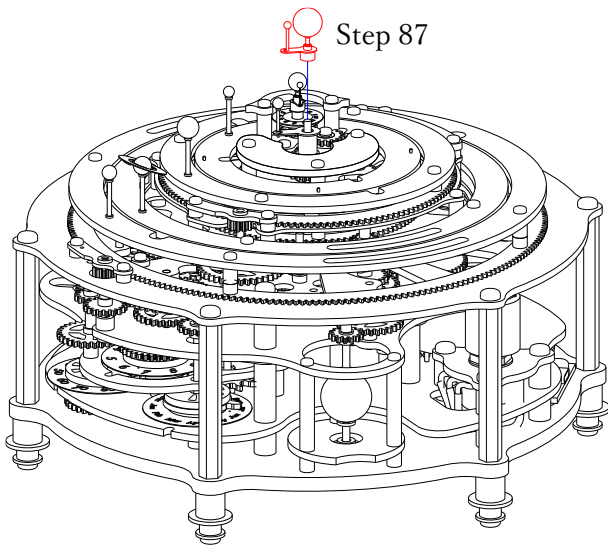

96.

97. Synchronize the Moon with the lunar phase. Turn on the switch and align the Sun, Earth, and Moon in a straight line. Adjust the Moon so that it is on the opposite side of the Earth from the Sun (full moon / total lunar eclipse).

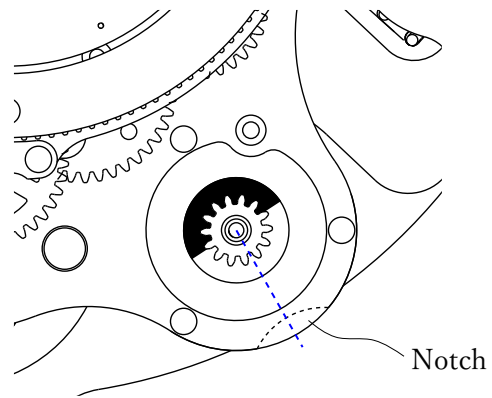
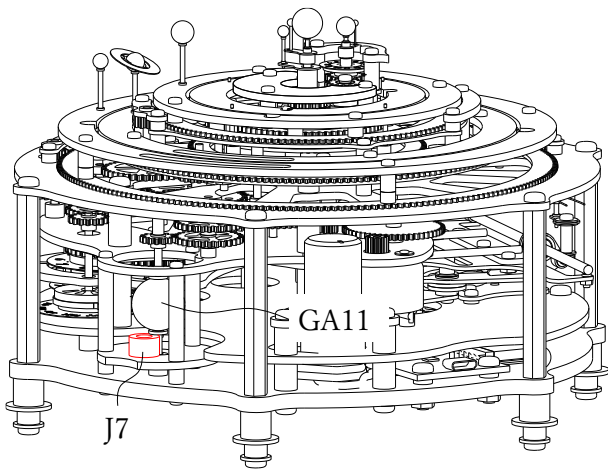

98. Insert J7 between the lunar phase and the panel, pressing the lunar phase against J7 to set its vertical position. Rotate GA11's lunar phase so that the white side (full moon) aligns with the center of the notch, then remove J7. Turn on the switch and rotate the Moon another full turn to confirm that the white side of the lunar phase aligns with the notch as in Step 97. If the lunar phase slips downward, insert J7, apply adhesive to the top side (Step 99), wait for it to dry, then repeat the above procedure.

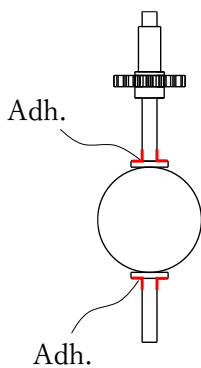

99. Bond the lunar phase to the shaft with adhesive so that it does not move.

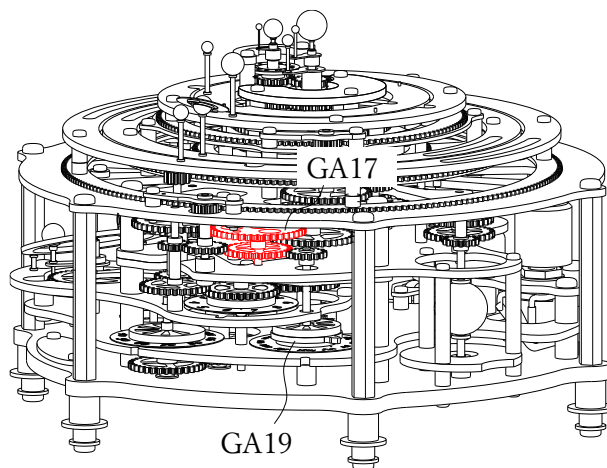
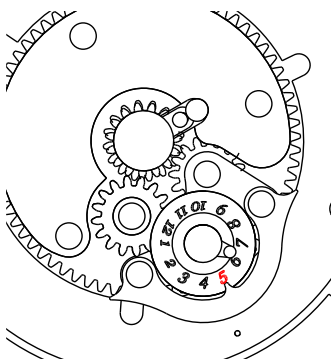

100. Synchronize the calendar with the Time scale. Turn on the switch and align the protrusion of the night phase with May on the calendar, then turn off the switch (see left figure; any month is acceptable). Lift GA17 to disengage it from GA19 (Month gear). (GA17 can come off easily, so be careful.)

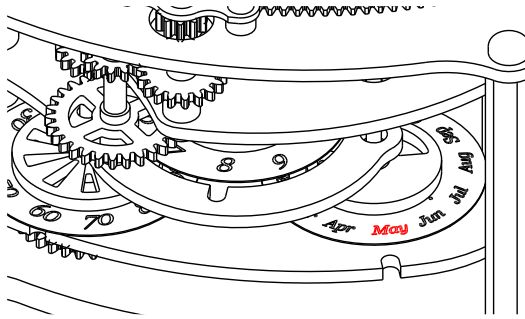

GA19 (Top view)

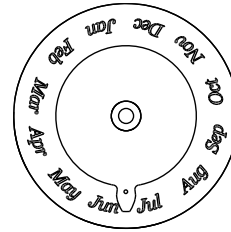

GA19 (Top right view)

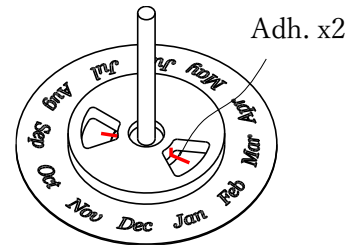

101. Rotate GA19 to align “May” with the center of the notch, then lower GA17 to engage with GA19. Adjust Steps 100 and 101 gradually until the calendar and GA19 (Month gear) display almost match (left figure). During adjustment, ensure that GA19’s teeth are near the center between “Jun” and “Jul” (center figure).

If “May” is slightly off-center after adjustment, hold GA19’s gear in place with your finger and slightly rotate the dial to align “May” with the center of the notch. (It is fine if the teeth are between “Jun” and “Jul.”) Apply adhesive between the brass dial and the lower veneer to bond them (move the Stellar Movements so the area to be bonded is on the front for easier adhesion).

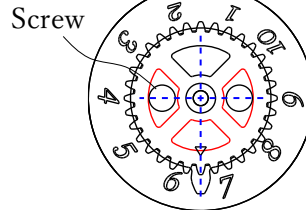
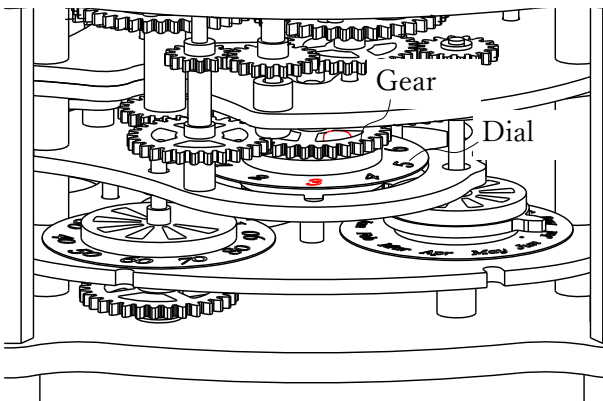

102. Adjust the year scale. Align the screw with the center of the gear gap as shown (right figure). Turn on the switch and check that the notch on the year scale aligns with the center of the number. If misaligned, hold the gear with your finger and rotate the dial to align the notch with the number. Repeat several rotations, fine-tuning until the misalignment is minimal.

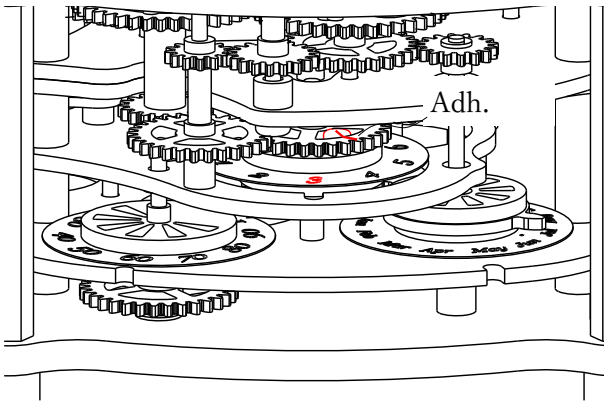

103. After completing Step 102, apply adhesive between the screw and the gear. Apply adhesive to the screw sections on the “4” and “9” sides of the dial.

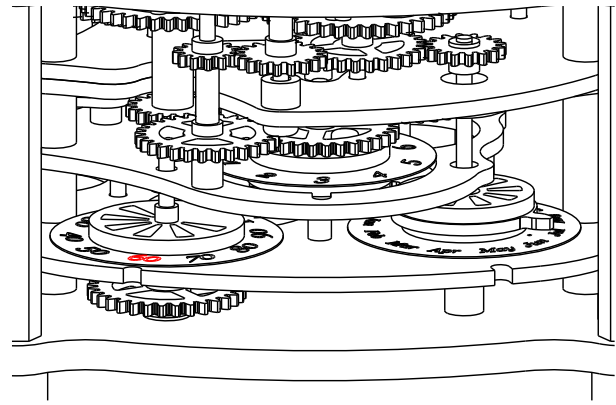

104. Adjust the 10-years scale. Turn on the switch and check that the notch aligns with the center of the number. If misaligned, hold the gear with your finger and rotate the dial to align the notch and number. Repeat several rotations until the alignment is correct.

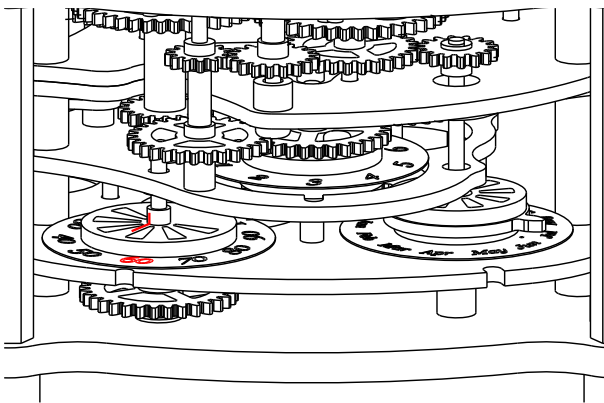

105. After Step 104, apply adhesive between the pipe and the dial.

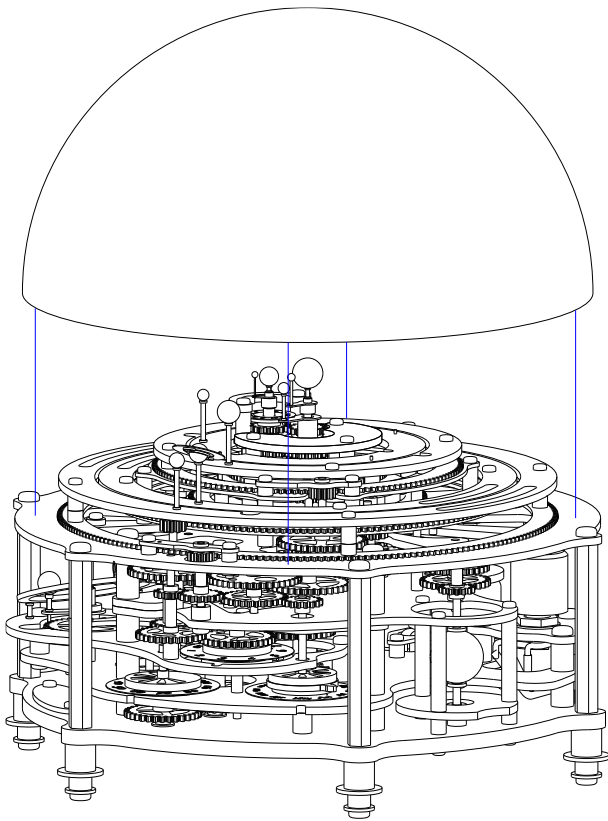

106. Place the L (acrylic dome) on top.
(Washing the acrylic dome with dish soap will
make it clean and clear.)

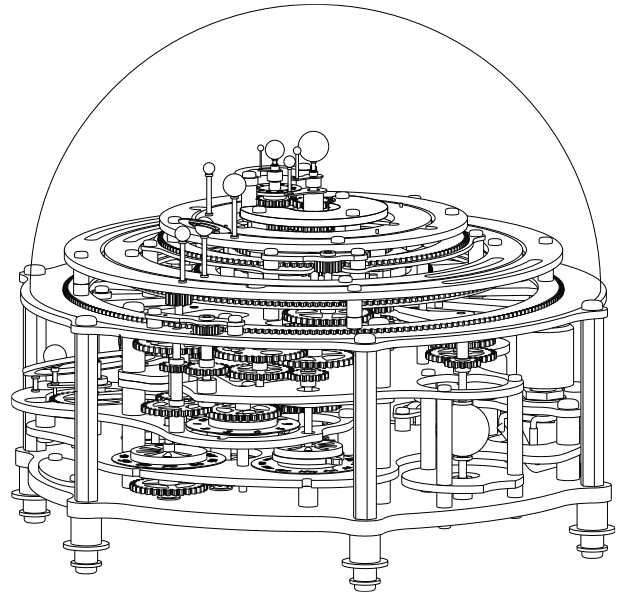

107. Complete !

How to Use and Enjoy

Part Names

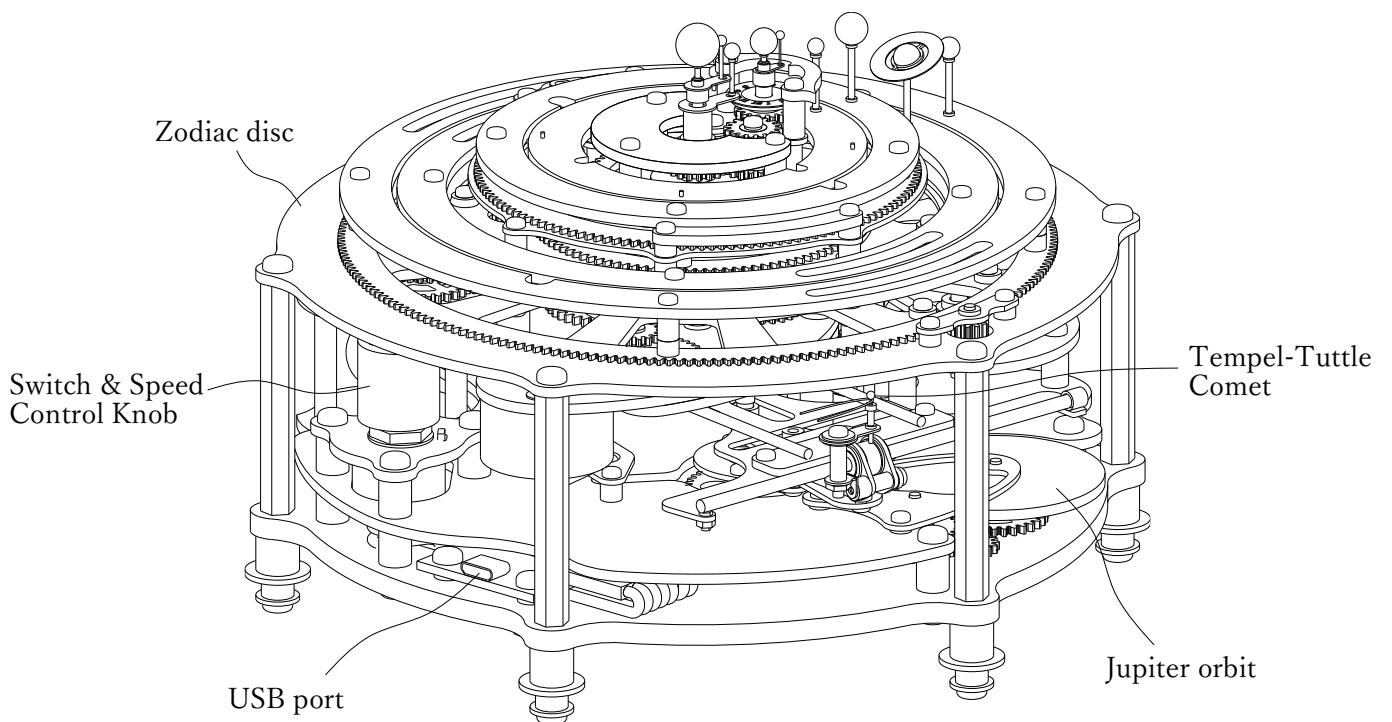
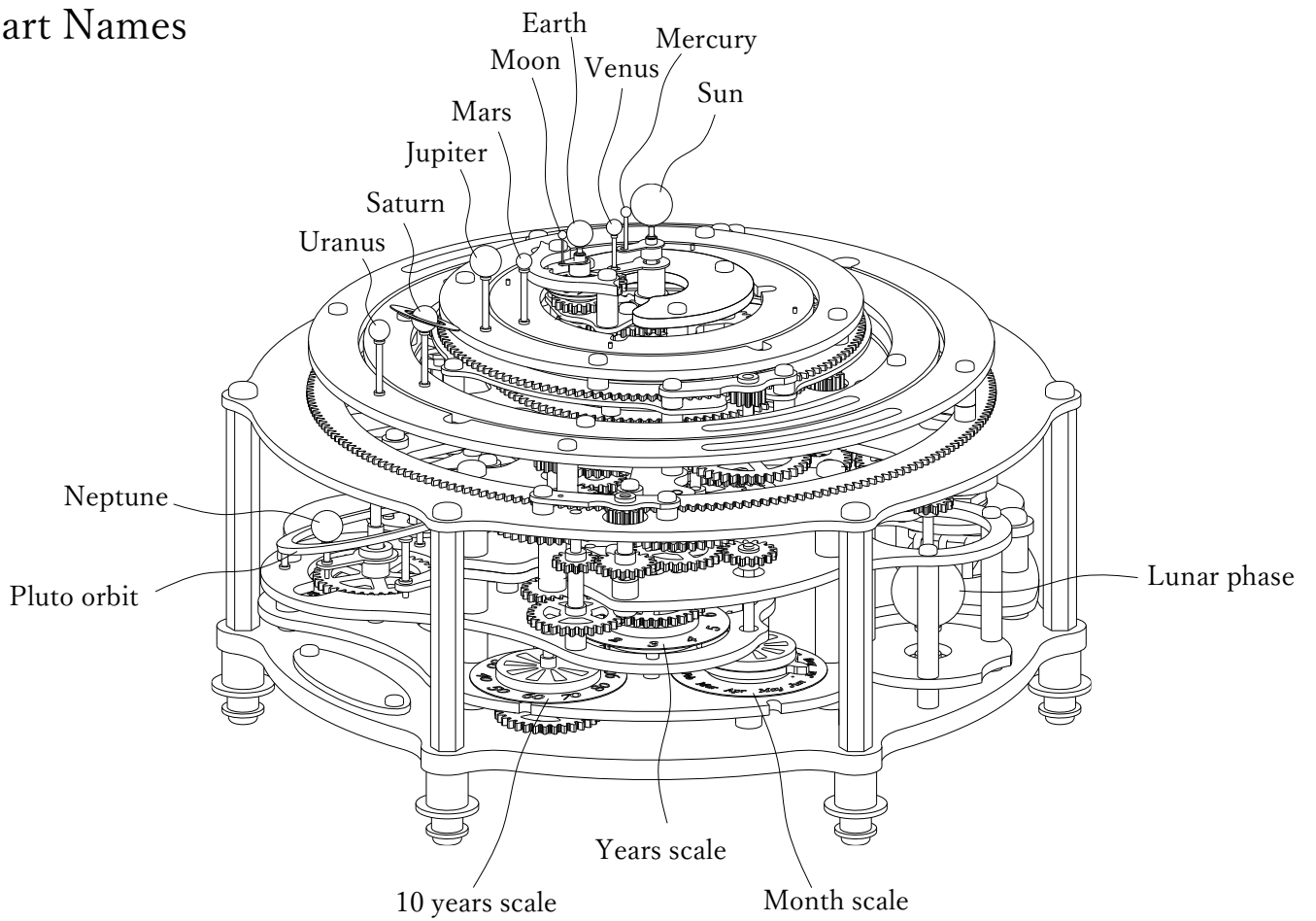

How to Use

- Connect the USB cable to the USB port on the Stellar Movements device, then plug it into a USB port on your computer or other device.
- Turn the switch & speed control knob clockwise until you hear a click; the power will turn on. Adjust the knob to set your desired speed.
- To turn off the power, rotate the switch & speed control knob counterclockwise until you hear a click again.

Viewing Instructions

night phase

The night phase indicates the night region on Earth and is always set to be on the opposite side of the Sun.

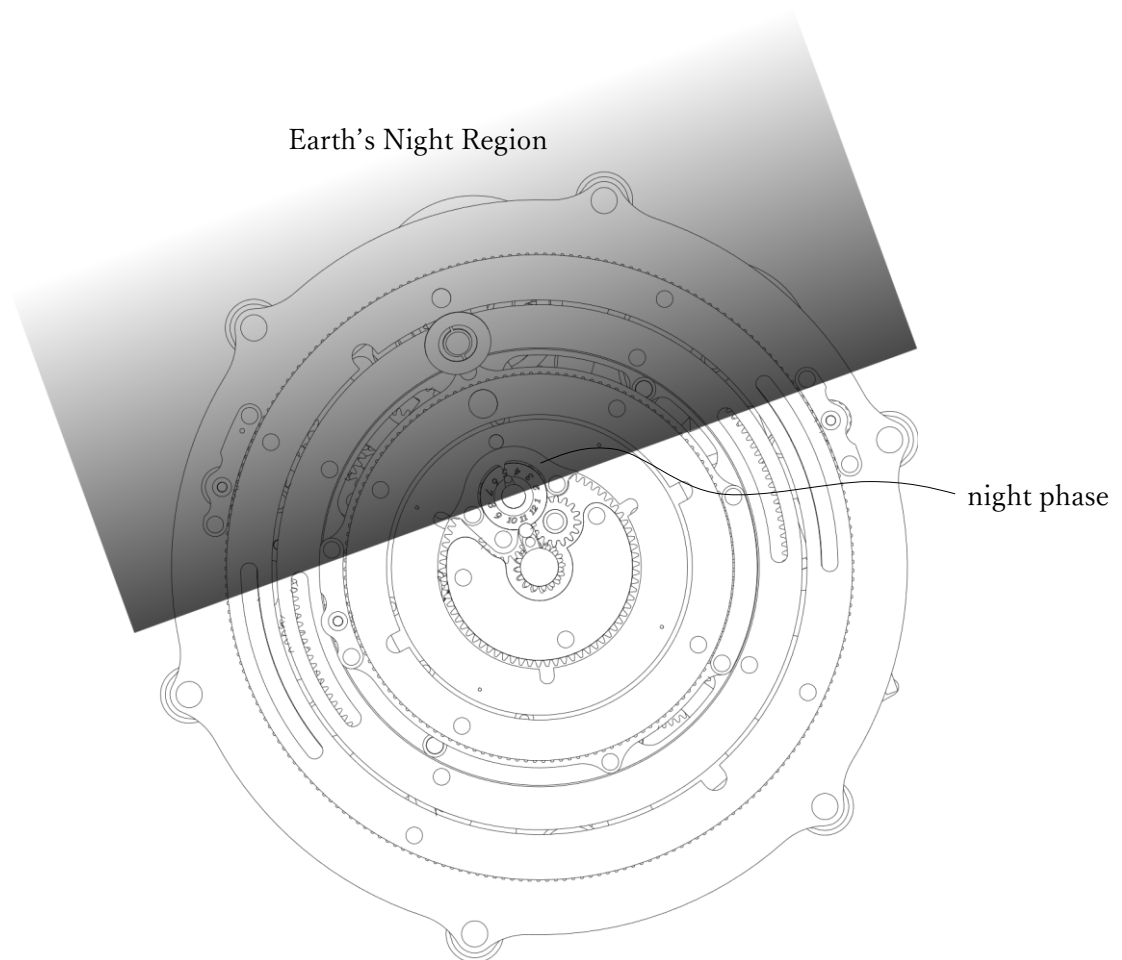

Calendar & Time Scales

The current date is indicated by the night phase protrusion. For example, if the protrusion points to “5” on the calendar, the current month is May. At this time, the month scale also points to “May.”

Time scale behavior is as follows:

Month scale: When changing from Dec → Jan, the Years scale advances by one step.

Years scale: When changing from 10 → 1, the 10 years scale advances by one step.

Neptune moves in sync with the 10 years scale, advancing one step every 10 years.

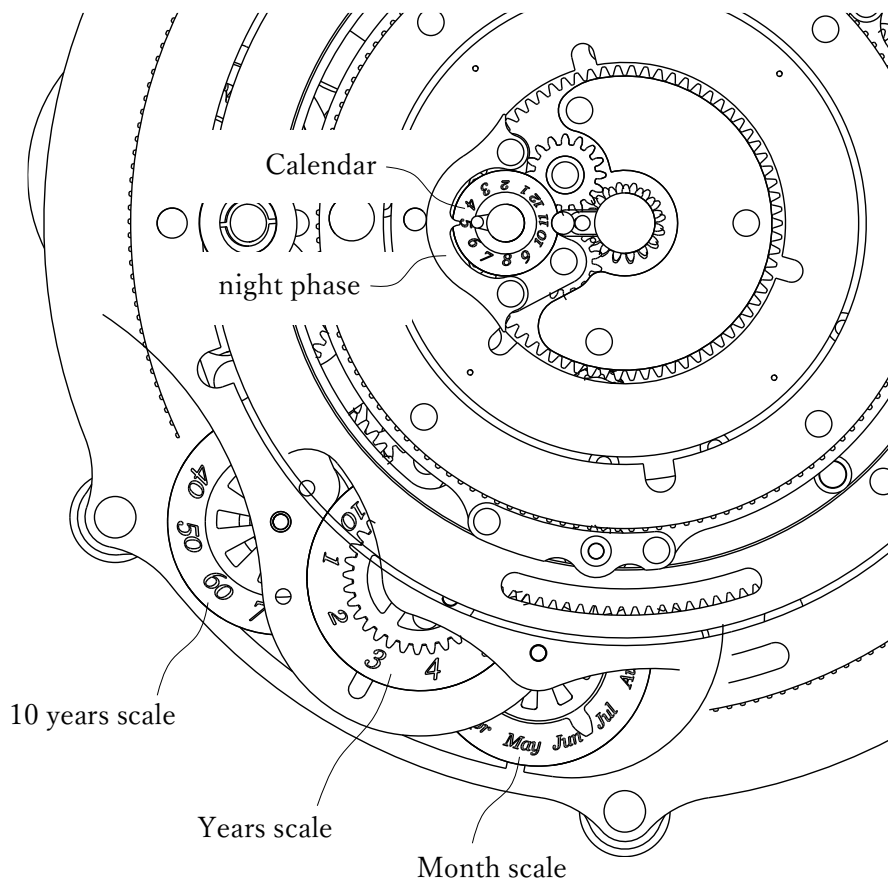

Correspondence between the calendar and Month scale in May

Lunar Phases

The lunar phase shows the illuminated portion of the Moon's surface as seen from Earth. For example, when the Moon is between Earth and the Sun, the dark portion of the Moon points toward the notch on the scale, indicating a new moon.

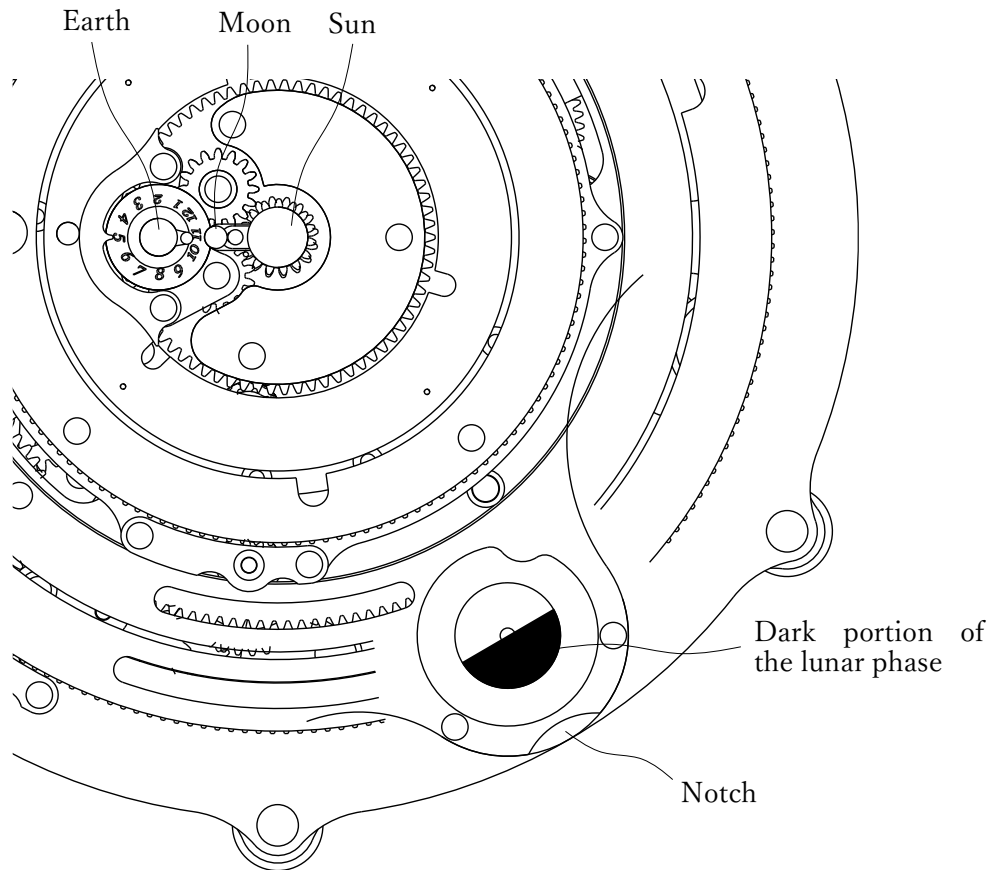

Diagram of Sun, Earth, and Moon configuration at new moon and corresponding moon phase

Zodiac Disc

The zodiac disc shows the constellations corresponding to the current month as seen from the Sun's perspective toward Earth.

For example, when the calendar shows "May," the corresponding constellations are TAURUS and GEMINI.

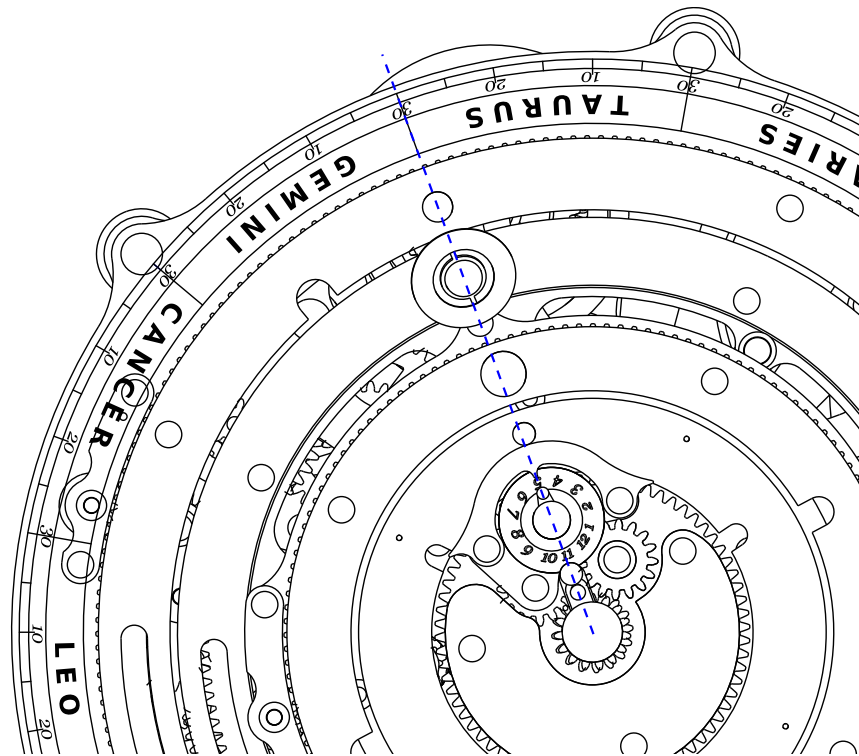

Diagram of constellations corresponding to May

Other Notes

For Quiet Operation

Reduce the operating speed or place a rubber pad (like a mouse pad) under the Stellar Movements device to reduce operational noise.

Care Instructions

Remove dust with a paintbrush or similar tool.

Avoid touching brass parts with bare hands as they can easily tarnish.

Storage

Avoid operating or storing the device in high temperature, high humidity, direct sunlight, or areas subject to vibration or impact.

Warranty

Please refer to the included warranty card.

After-Sales Service

For repairs, cleaning, or purchasing replacement parts, please visit the following website.

<https://olenoides.com/maintenance/>

Revision History

Date	Rev	Description of Revision
Apr. 20, 2026	-	First edition